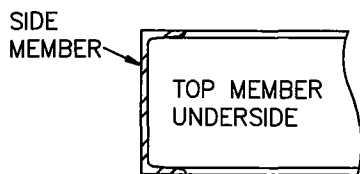
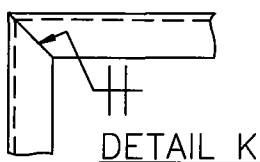
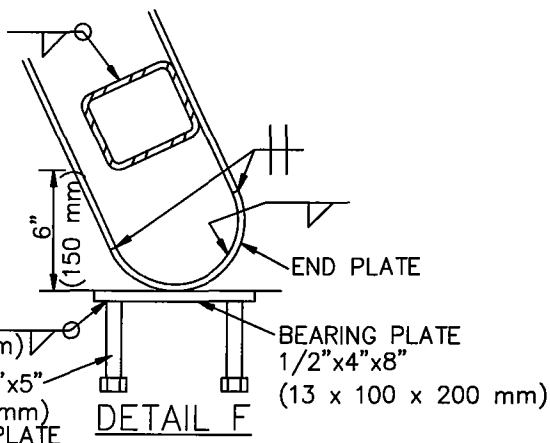
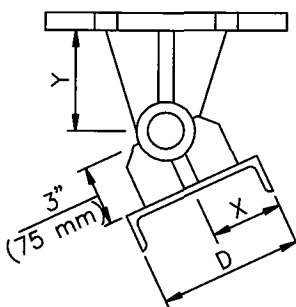

TABLE 3 - HINGES

BOX SIZE, W x H	NO. OF HINGES	HINGE SIZE
4'x4' (1.2 x 1.2 m)	2	12" (300)
4'x6' (1.2 x 1.8)	2	12" (300)
4'x8' (1.2 x 2.4)	2	12" (300)
6'x4' (1.8 x 1.2)	2	18" (450)
6'x6' (1.8 x 1.8)	2	18" (450)
6'x8' (1.8 x 2.4)	2	18" (450)
6'x10' (1.8 x 3.0)	2	18" (450)
8'x4' (2.4 x 1.2)	3	12" (300)
8'x6' (2.4 x 1.8)	3	12" (300)
8'x8' (2.4 x 2.4)	3	12" (300)
8'x10' (2.4 x 3.0)	3	12" (300)
10'x6' (3.0 x 1.8)	3	18" (450)
10'x8' (3.0 x 2.4)	3	18" (450)
10'x10' (3.0 x 3.0)	3	18" (450)
12'x6' (3.6 x 1.8)	3	24" (600)
12'x8' (3.6 x 2.4)	3	24" (600)
12'x10' (3.6 x 3.0)	3	24" (600)
14'x6' (4.2 x 1.8)	3	24" (600)
14'x8' (4.2 x 2.4)	3	24" (600)
14'x10' (4.2 x 3.0 m)	3	24" (600)

TABLE 4 - HINGE CLEARANCES (mm)

D	X	Y
4" (10)	2" (50)	3" (75)
5" (127)	2 1/2" (65)	3 1/2" (90)
6" (152)	3" (75)	4" (100)
7" (178)	3 1/2" (90)	4 1/2" (115)
8" (203)	4" (100)	5" (125)
9" (229)	4" (100)	5" (125)



SECTION C-C

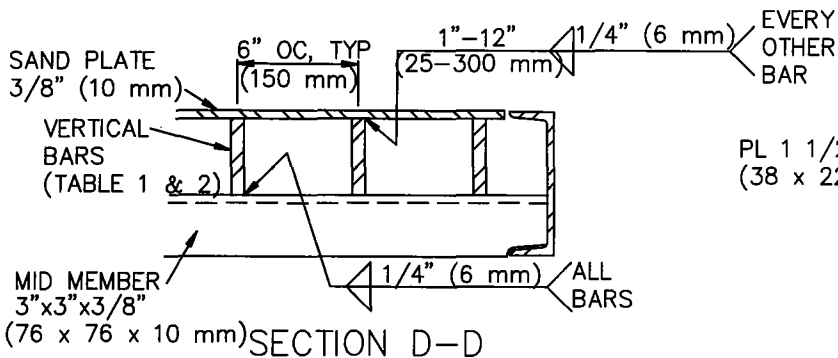
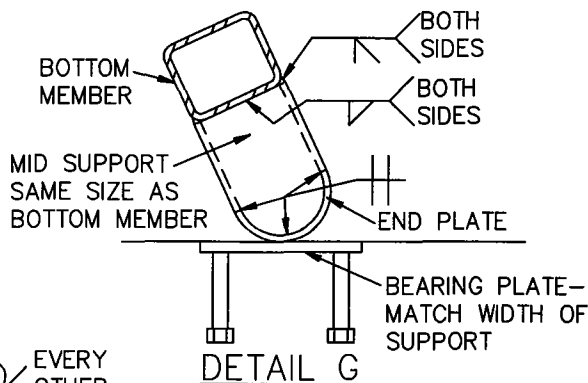

SECTION D-D

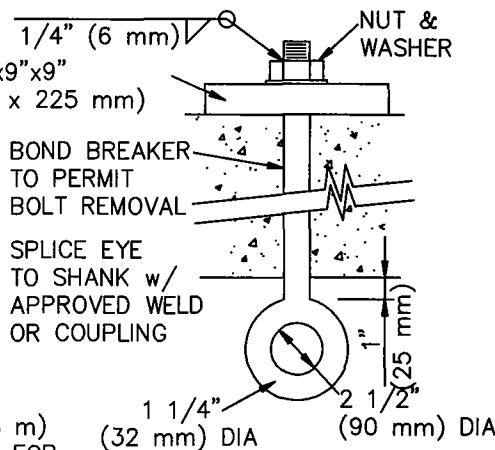

DETAIL J

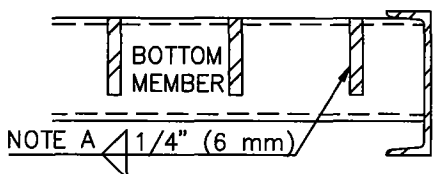

SECTION E-E

NOTE A:
 WELDS 1" (25 mm) FOR
 H = 4' & 6' (1.2 & 1.8 m)
 WELDS 1 1/2" (40 mm) FOR
 H = 8' & 10' (2.4 & 3.0 m)