

SECTION A - A

SECTION B - B

DIMENSIONS (in)				
PIPE DIA.	36	42	48	54 AND GREATER
B	20	14	8	EQUALS PIPE WALL THICKNESS
E	32	38	44	48

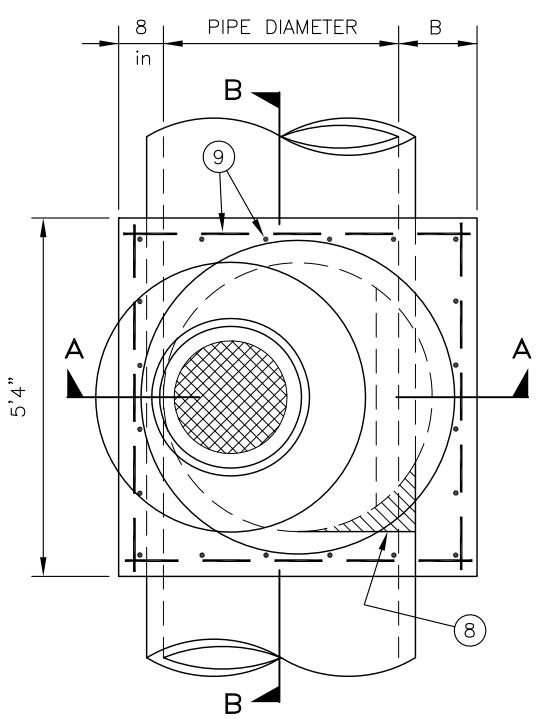

PLAN

NOTES:

- ① PRECAST PIPE, ADJUSTING RINGS, AND TAPERED SECTIONS SHALL BE CONSTRUCTED AS PER A.S.T.M. C-478, USING TYPE II CEMENT.
- ② ALL JOINTS BETWEEN PRECAST SECTIONS SHALL BE MORTARED.
- ③ MANHOLE INTERIORS SHALL HAVE A SMOOTH TROWELLED SURFACE.
- ④ FOR R.C.P. CUT AND BEND REBAR INTO CAST-IN-PLACE CONCRETE.
- ⑤ STEPS SHALL BE INCLUDED IF MANHOLE DEPTH EXCEEDS 4', STEPS SHALL BE STEEL-REINFORCED POLYPROPYLENE, M-A INDUSTRIES PS2-PFS, OR EQUAL.
- ⑥ IN MANHOLES WITH LATERAL CONNECTIONS THE STEPS SHALL BE PLACED IN THE WALL WITH NO LATERALS, OR THE WALL WITH THE LEAST DIAMETER LATERAL, SUCH THAT A CONTINUOUS VERTICAL ALIGNMENT OF STEPS MAY BE ACHIEVED.
- ⑦ COLLAR SHALL BE CONSTRUCTED PER CITY ENGINEERING STANDARD #6040.
- ⑧ PROVIDE P.C.C. FILLETS AS NEEDED TO SUPPORT MANHOLE SHAFT, 4 EACH.
- ⑨ #4 BAR @ 12" O.C. EA. WAY, 3" CLR. TYP.
- ⑩ CONSTRUCT CLASS 2 PCC BASE TO DIMENSIONS SHOWN ABOVE. IT SHALL REST ON UNDISTURBED MATERIAL AND BOTTOM SHAFT SHALL BE WET-SET OR SET IN FORMED GROOVE.

REVISIONS	BY	APP	DATE
New border	JDL	WAP	9-97
Add Note 10	JDL	WAP	7-00
Revise re-bar specs	JDL	WAP	11-98
STANDARD CURRENT AS OF: January 2008			



STORM DRAIN MANHOLE  
36" PIPE & LARGER