

SINGLE CULVERT

MULTIPLE CULVERTS

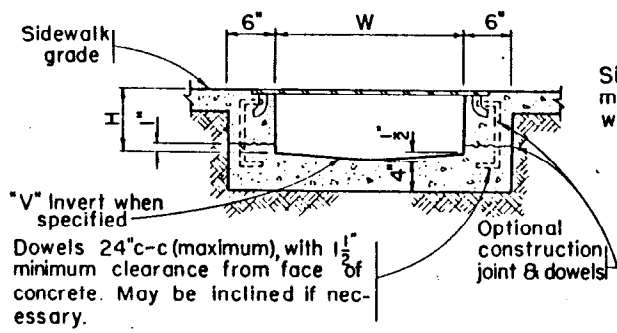

SECTION A-A

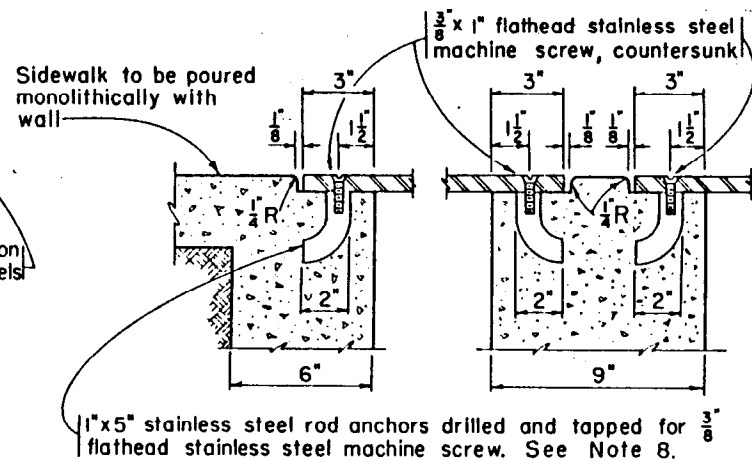

SECTION C-C

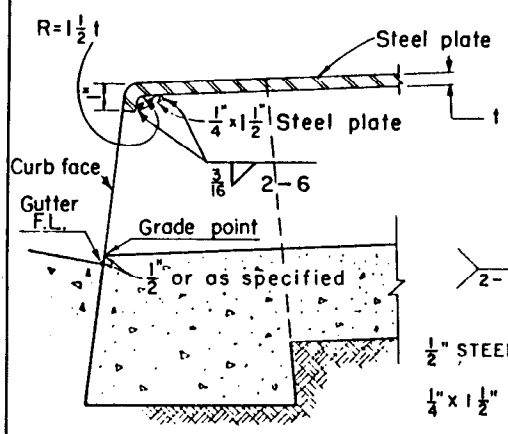

ALTERNATE 1

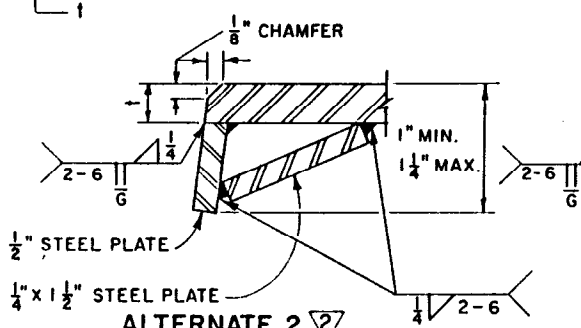

ALTERNATE 2

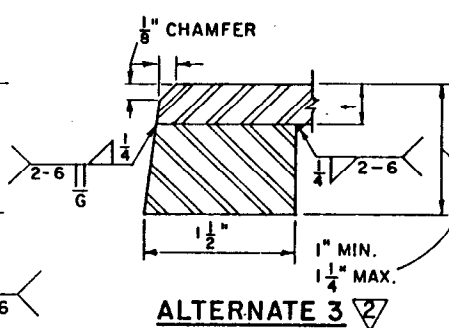

ALTERNATE 3

SECTION D-D

DEPARTMENT OF PUBLIC WORKS

BUREAU OF ENGINEERING

CITY OF LOS ANGELES

SIDEWALK CULVERT WITH STEEL PLATE TOP

STANDARD PLAN

S-322-2

SUBMITTED *Aug 12 1974*

REVISIONS

SUPERSEDES REFERENCES

APPROVED *11-14-75*

NO.	DATE	DESCRIPTION	DESCRIPTION	ENGR OF DESIGN	CITY ENGR.
2		REVISED SECTION D-D AND ADDED NOTE 9 TO ALLOW ALTERNATES TO THE BEND IN THE STEEL PLATE AT THE CURB FACE; REVISED NOTE 7 TO ALLOW CERTIFICATION BY A REGISTERED MECHANICAL ENGINEER.		<i>See above</i>	<i>Robert J. Horne</i>

B-4070

DESIGNED BY *L.A.S.* DRAWN BY *O.R.* CHECKED BY *L.S.P.*

VAULT INDEX NO. B-4083

SHEET 1 OF 2 SHEETS

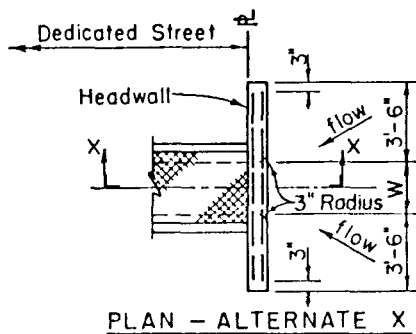

PLAN - ALTERNATE X

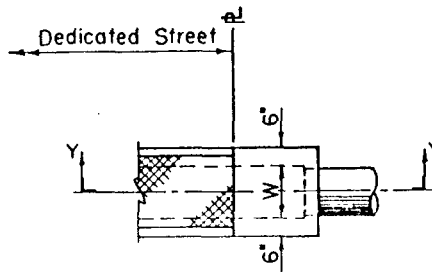

PLAN - ALTERNATE Y

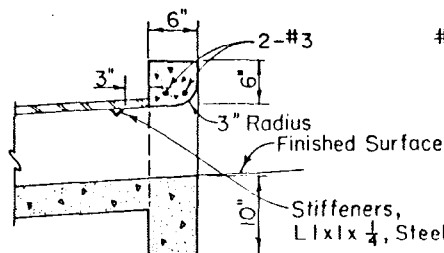

SECTION X-X

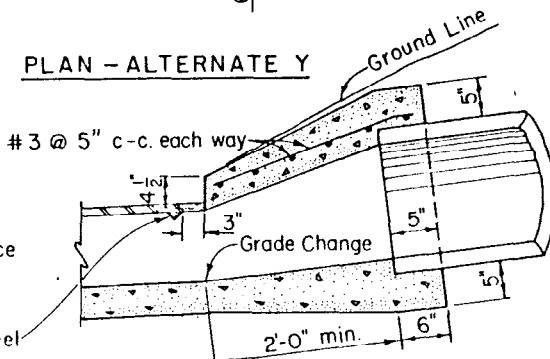

SECTION Y-Y

ALTERNATE INLETS

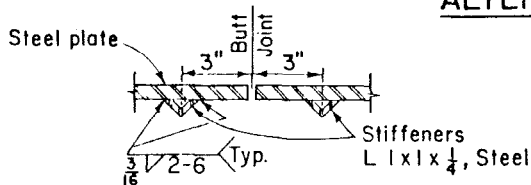

SECTION E-E

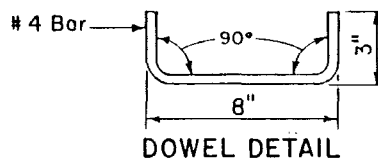

DOWEL DETAIL

NOTES

1. Values for Angle F and dimensions J-K, L-M, W and H are shown on the improvement plan.
2. Concrete shall be 560-C-3250.
3. Surface of all exposed concrete shall match grade, color, finish and scoring of adjacent curb and walk.
4. Any curb replaced during construction shall be poured monolithically with the culvert walls.
5. The bottom slab of the culvert shall be poured monolithically with new gutter or as a cold joint where joining existing gutter.
6. Invert shall be troweled and retroweled to produce a hard polished surface of maximum density and smoothness. If "V" invert is specified, it shall be V-shaped to within 3' of the outlet and warped from this point to the outlet. The invert at the outlet shall parallel the gutter flow line unless otherwise shown on the improvement plan.
7. Culvert steel top plates shall be as follows:
 - A. $t = 1/4"$ for $W \leq 2'$; $3/8"$ for $2' < W \leq 3'$; $1/2"$ for $3' < W \leq 4'$.
 - B. Cut perpendicular to culvert walls unless otherwise specified.
 - C. Lengths shall be such that the weight per plate does not exceed 300 pounds.
 - D. They shall be stress relieved and straightened after fabrication and then galvanized.
 - E. Top of steel plate shall have a minimum coefficient of static friction of 0.5, for either wet or dry conditions, when tested for any shoe sole material. Testing and certification of the friction factor shall be conducted by an independent testing laboratory approved by the Engineer under the direction of a registered Civil, Mechanical or Quality Engineer. Testing shall conform to ASTM D2047 or F 489 or F 609 or other procedure approved by the Engineer.
8. Stainless steel rod anchors shall be spaced a maximum of 24" c-c with a minimum of two per side per plate. There shall be an anchor within 6" of each end. The anchors shall be attached to the plates and the plates secured in place prior to pouring the walls.
9. The contractor may, at his option, utilize any of the three alternates for the fabrication of the steel plate at the curb face shown in section D-D.