

EAST JORDAN  
 IRON WORKS, INC.  
 P.O. BOX 439  
 EAST JORDAN, MI. 49727  
 1-800-874-4100  
 FAX 231-536-4458

DRAWN  
 SMH

DATE  
 07/30/01

APPROVED

DATE

# 9" MOORING EYE

PRODUCT NO.

**00599900**

CATALOG NO.

**9" MOORING EYE**

REF. PRODUCT DRAWING

00599900

EST. WT.

MOORING EYE: 125LBS 57kg

OPEN AREA

N/A

MAT'L SPEC.

MOORING EYE - DUCTILE IRON  
 ASTM A536

LOAD RATING

**9000LBS**

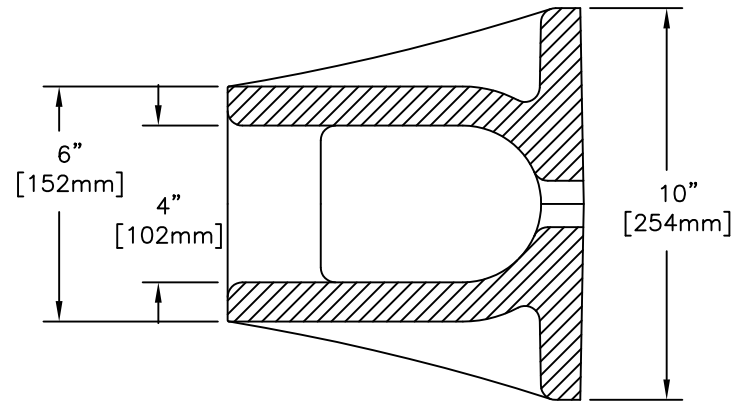
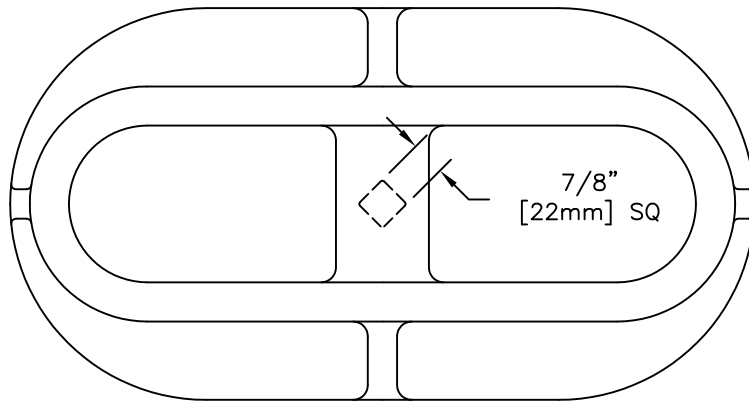

SECTION

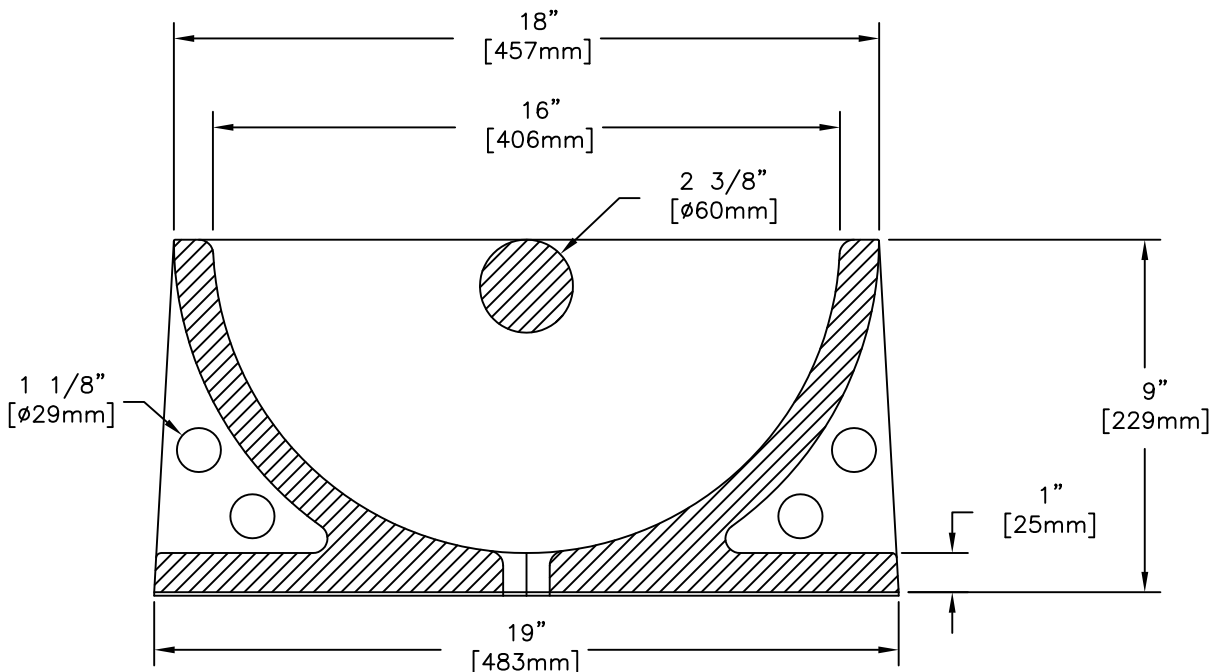

SECTION