

PLAN VIEW

NOTE:
ALL FILLET RADII 1/8"
UNLESS OTHERWISE NOTED.

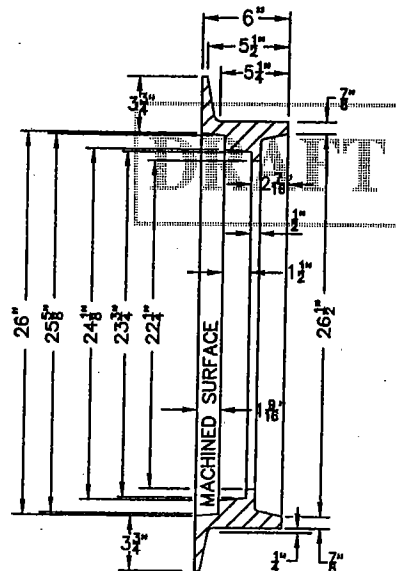

SECTION A-A

MANHOLE FRAME

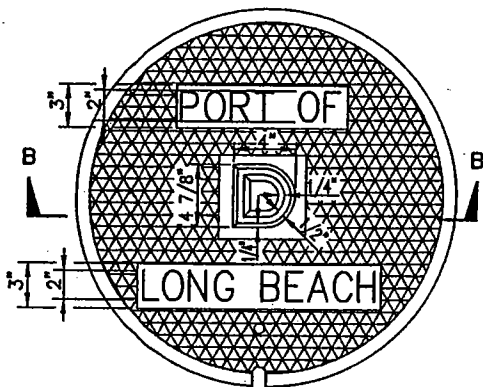

PLAN OF TOP
FOR STORM DRAIN COVER

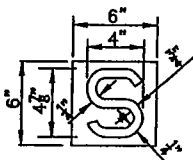

PLAN OF LETTER
FOR SEWER COVER

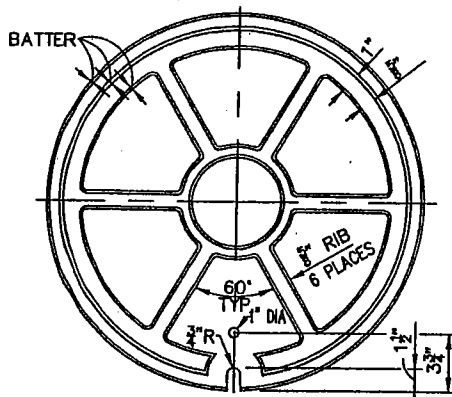

PLAN OF BOTTOM

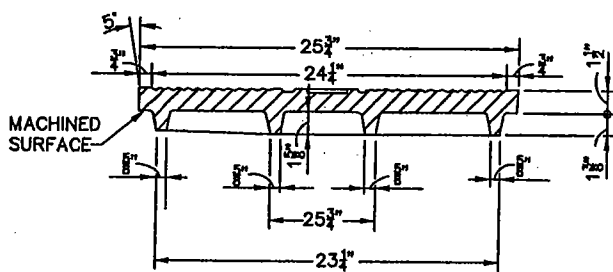

SECTION B-B

FOR NOTES SEE STANDARD PLAN D-17

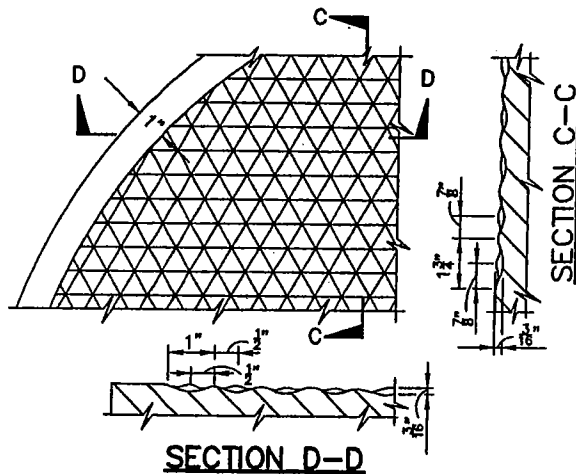

SECTION D-D

MANHOLE COVER

THE PORT OF LONG BEACH ENGINEERING DIVISION

REVISIONS	
NO.	DATE
⚠	
⚠	
⚠	

INVERTED MANHOLE FRAME AND COVER

STANDARD PLAN

D-18

APPROVED BY: _____ CHIEF HARBOR ENGINEER _____ R.E. NO.: _____ DATE: _____

1 OF 1