

# 3163C Cover

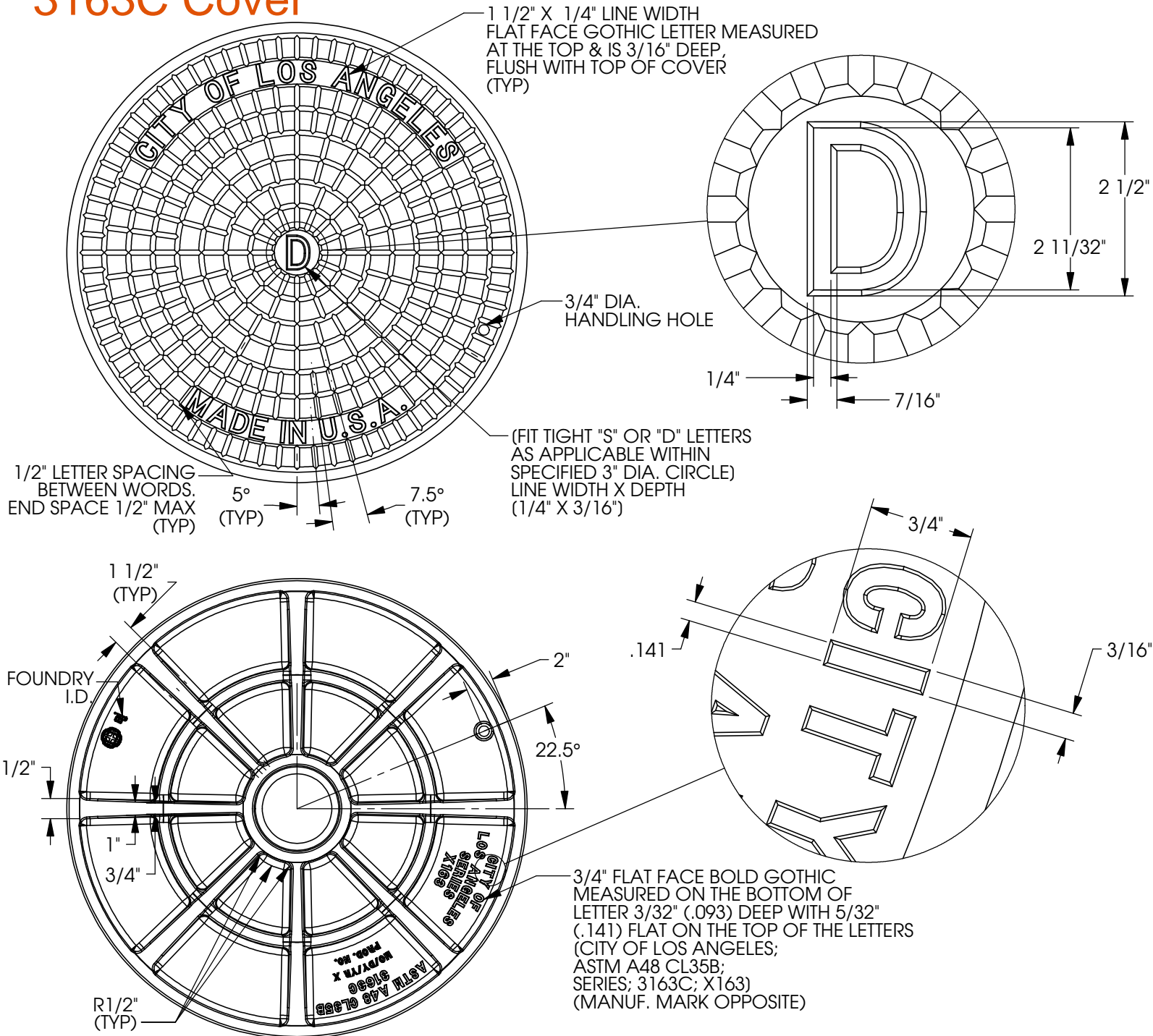

## Product Number

00316376

## Design Features

- Materials  
Gray Iron (CL35B)
- Design Load  
Heavy Duty  
Proof Load Tested to 53,200 LBS.
- Open Area  
n/a
- Coating  
Asphaltic Coated
- √ Designates Machined Surface

## Weight

MIN. 305 LBS.  
MAX. 335 LBS.

## Certification

- ASTM A48
- 
- Country of Origin: USA

## Manufacturing Facility

ARDMORE, OK., USA

Fabrication Inspection  
Required.

## Drawing Revision

11/18/2011 Designer: SMM  
12/10/2013 Revised By: MAH

## Contact

800 626 4653  
ejco.com

# 3163C Cover

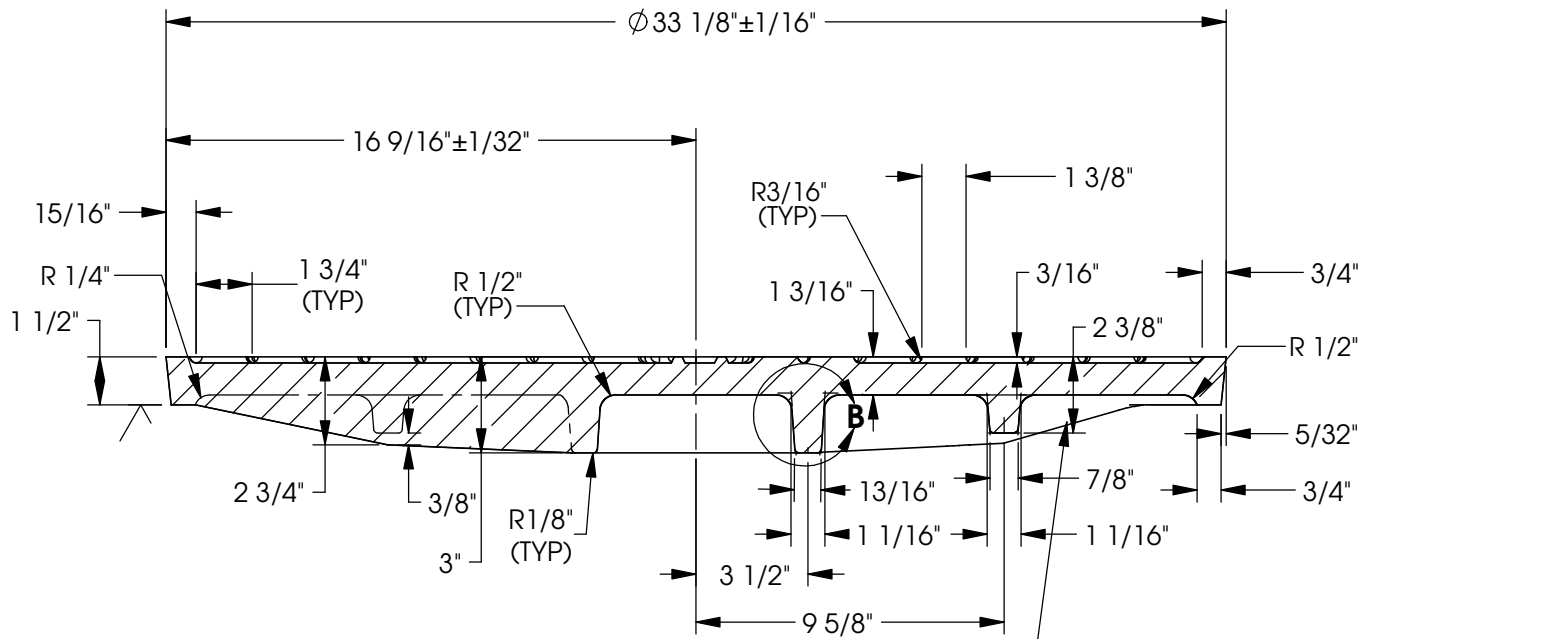

**SECTION A-A**  
 NOTE: RIGHT SIDE OF CROSS SECTION A-A IS CUT BETWEEN RIBS SHOWING THE SEAT PROFILE, SEE LEFT SIDE OF SECTION A-A FOR BEGINNING OF CROSS RIB

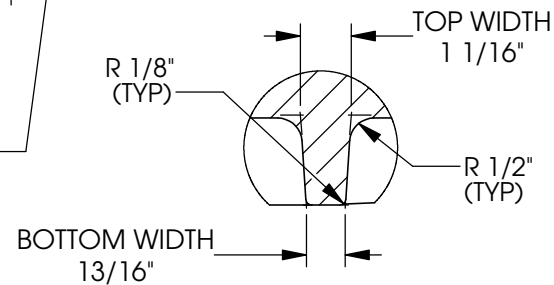

**DETAIL B**

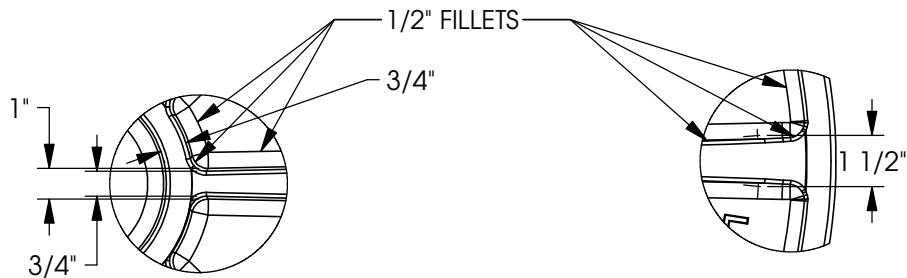

**RIB VIEW DETAIL**

**RIB VIEW DETAIL**

**Product Number**

00316376

**Design Features**

- Materials  
Gray Iron (CL35B)
- Design Load  
Heavy Duty  
Proof Load Tested to 53,200 LBS.
- Open Area  
n/a
- Coating  
Asphaltic Coated
- √ Designates Machined Surface

**Weight**

MIN. 305 LBS.  
 MAX. 335 LBS.

**Certification**

- ASTM A48
- 
- Country of Origin: USA

**Manufacturing Facility**

ARDMORE, OK., USA

Fabrication Inspection  
 Required.

**Drawing Revision**

11/18/2011 Designer: SMM  
 12/10/2013 Revised By: MAH

**Contact**

800 626 4653  
 ejco.com

# 3163C Cover

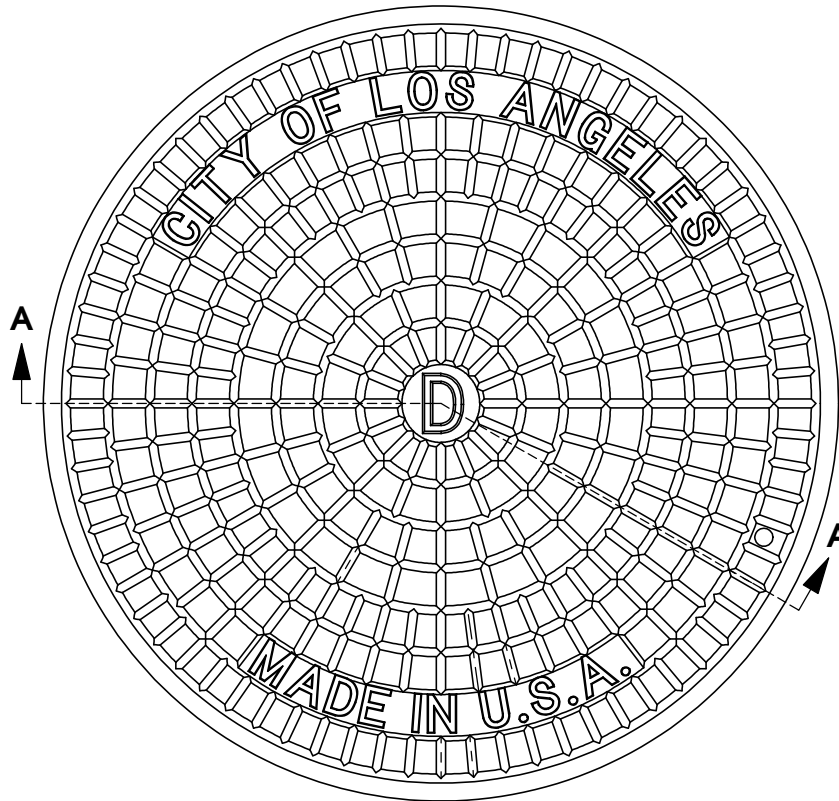

## Product Number

00316376

## Design Features

- Materials  
Gray Iron (CL35B)
- Design Load  
Heavy Duty  
Proof Load Tested to 53,200 LBS.
- Open Area  
n/a
- Coating  
Asphaltic Coated
- √ Designates Machined Surface

## Weight

MIN. 305 LBS.  
MAX. 335 LBS.

## Certification

- ASTM A48
- 
- 
- Country of Origin: USA

## Manufacturing Facility

ARDMORE, OK., USA

Fabrication Inspection  
Required.

**SEE DETAIL VIEWS FOR ALL DIMENSIONS AND SPEC. INFORMATION**

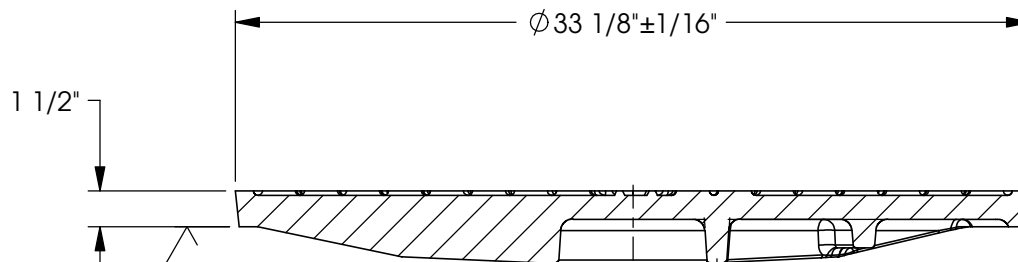

**SECTION A-A**

## Drawing Revision

11/18/2011 Designer: SMM  
12/10/2013 Revised By: MAH

## Contact

800 626 4653  
ejco.com