

1812Z2/2812APT EXHD DI ASSEMBLY

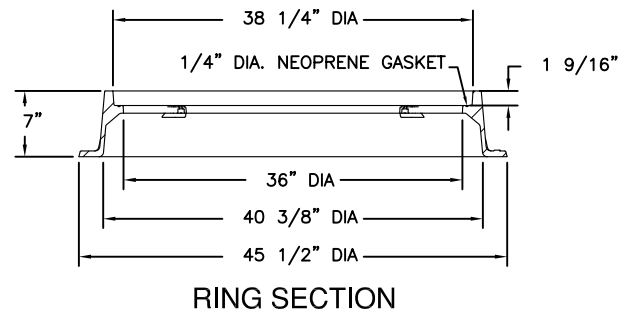
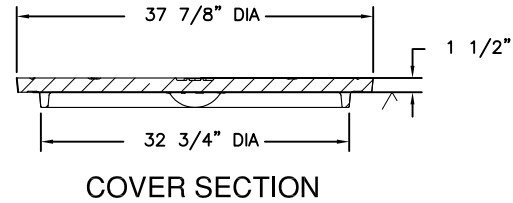
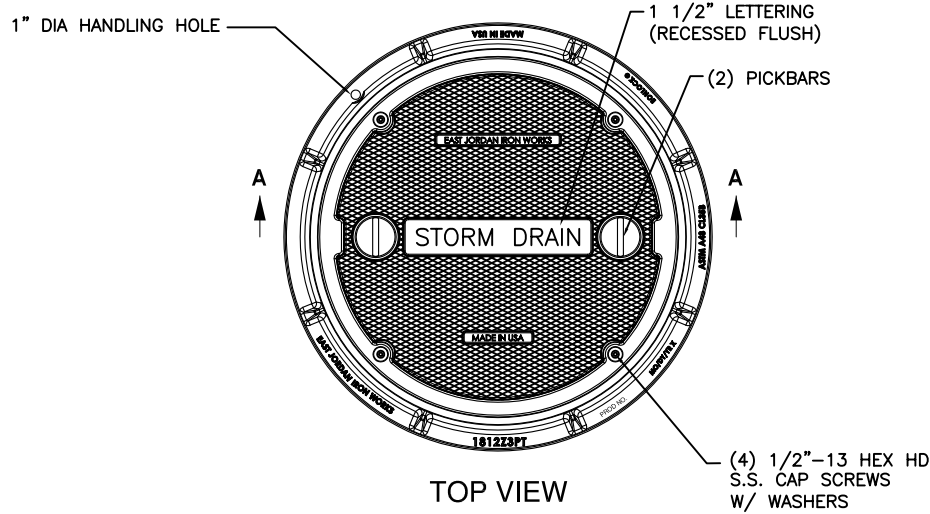

PRODUCT NUMBER

00281256W01

DESIGN FEATURES

MATERIALS

COVER-DUCTILE IRON
ASTM A536

FRAME-GRAY IRON
ASTM A48 CL35B

DESIGN LOAD

EXTRA HEAVY DUTY
(PROOF LOAD TESTED
TO 200,000 LBS)

COATING

UNDIPPED

OPEN AREA

N/A

√ DESIGNATES MACHINED SURFACE

REFERENCE INFORMATION

00181217
00281256

DRAWING DETAILS

ORIGINAL DRAWING: DEF 02/12/10

REVISED BY: DAL 04/05/10

Corporate
Headquarters
301 Spring Street
PO Box 439
East Jordan, MI
49727-0439
800.874.4100

EJ GROUP®

Call Today for
More Information

800.626.4653

EJIW EAST JORDAN
IRON WORKS EST 1883
WE COVER YOUR INFRASTRUCTURE

www.ejiw.com
MADE IN THE USA

- Weights (lbs./kg.), dimensions (inches/mm.), and drawings provided for your guidance.
- We reserve the right to modify specifications without prior notice.
- Uncontrolled distribution.

CONFIDENTIAL: This drawing is the property of East Jordan Iron Works, Inc., and embodies confidential information, registered marks, trade secret information, and/or know how that is the property of East Jordan Iron Works, Inc. ©Copyright 2009 East Jordan Iron Works, Inc.