

HALF PLAN FRAME & COVER

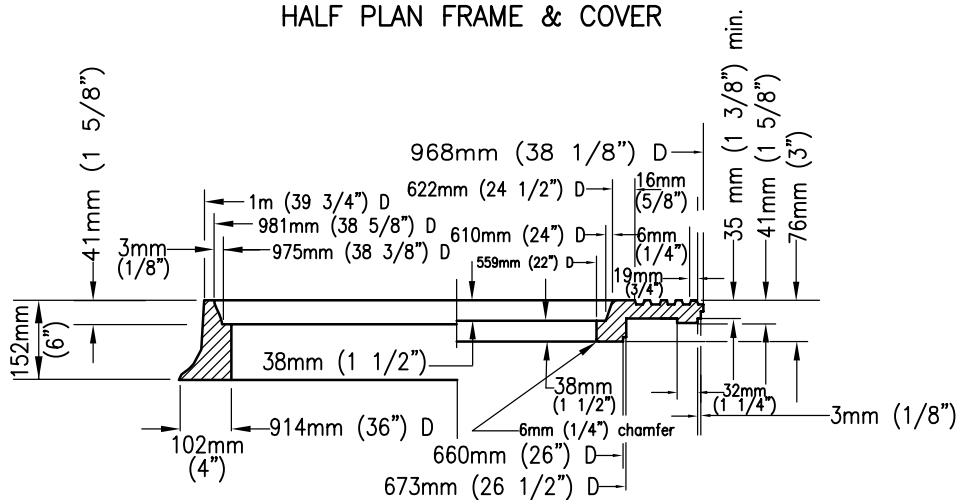

HALF SECTION FRAME & COVER

NOTES

1. Frame and cover shall be cast iron. Cast iron shall conform to ASTM 48, Class 35B.
2. Weights: Frame 142.4kg (314) - 164.6kg (363) lbs.  
Outer Cover 129.3kg (285) - 149.7kg (330) lbs.  
Inner Cover 66.7kg (147) - 77.5kg (171) lbs.
3. Machine all matching surfaces and seats of frame and cover to prevent rocking.
4. Imported frames and covers shall have the country of origin marked in compliance with federal regulations.

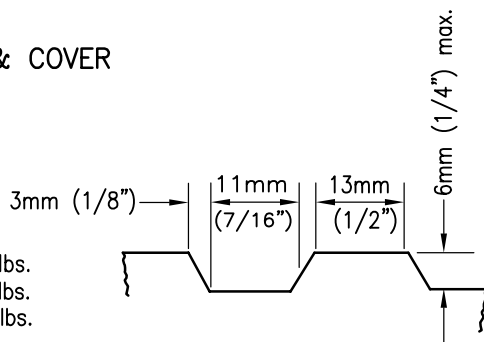

DETAIL

Revision	By	Approved	Date
ORIGINAL		Kercheval	12/75
Add Metric		T. Stanton	03/03
Reviewed		T. Stanton	04/06

SAN DIEGO REGIONAL STANDARD DRAWING

914mm (36") MANHOLE FRAME  
AND TWO CONCENTRIC COVERS  
HEAVY DUTY

RECOMMENDED BY THE SAN DIEGO REGIONAL STANDARDS COMMITTEE

*T. Stanton* 3/01/2003

Chairperson R.C.E. 19246 Date

DRAWING  
NUMBER

M-3