

PLAN

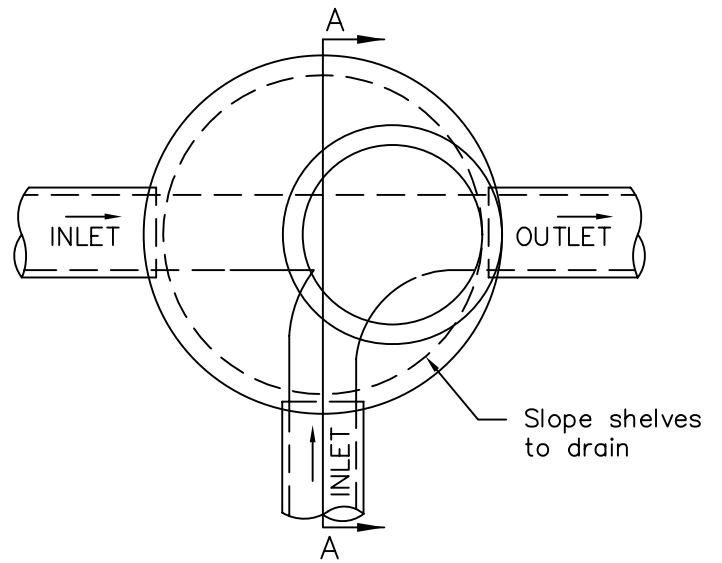

SECTION B-B

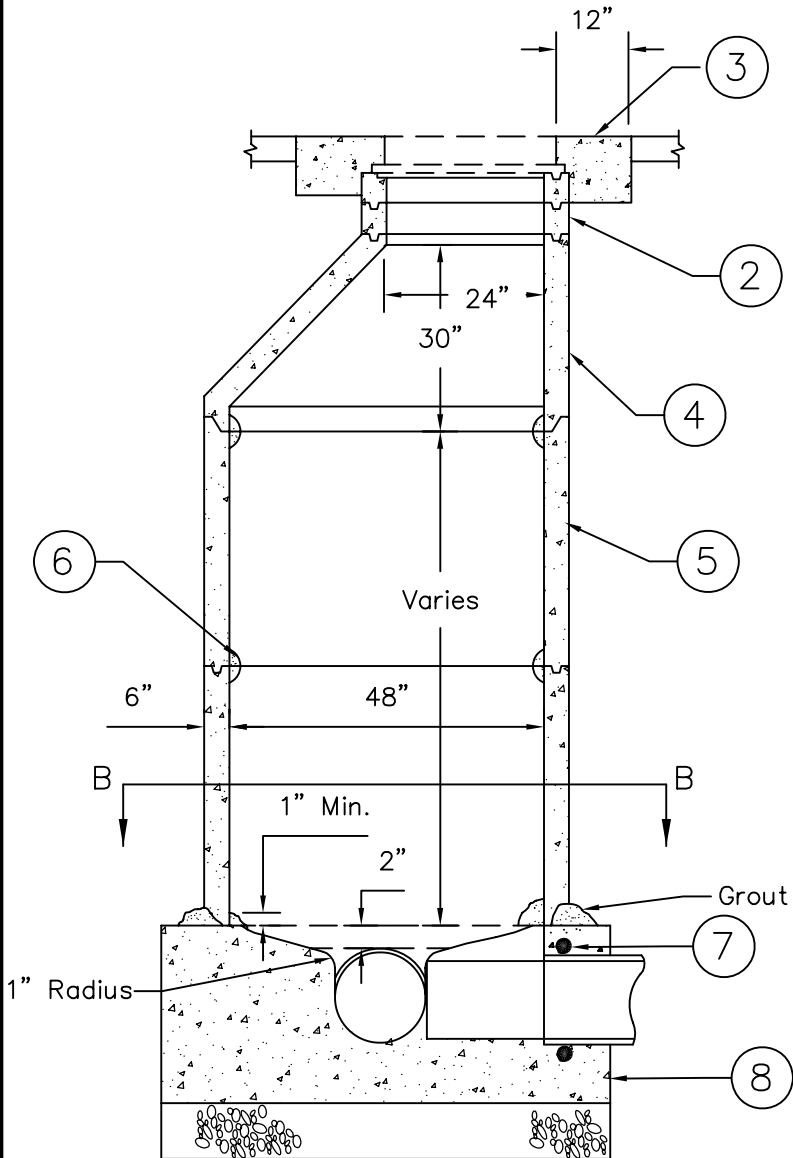

SECTION A-A

NOTES:

1. Manhole frame and cover shall have a 24" clear opening and shall conform to APWA Standard Plan 630-2 or use Model SBF 1495. Cover shall be lettered "SANITARY SEWER". Lid shall be rattle free without the use of a sealant.
2. Use only 3" or 6" adjustment rings. Cone top to frame top shall not exceed 15". Grade rings and manhole frame shall be sealed at every joint with butyl rubber (Conseal CS-102 or equal) and grouted on the inside.
3. PCC Collar shall conform to Standard Plan 638-AG.
4. Cones shall be eccentric and conform to riser requirements. Straight side of the cone shall be positioned over outlet.
5. Manhole risers shall be 48" in diameter and shall conform to ASTM C478 for Precast Reinforced Manhole Sections.
6. Joints shall be set with butyl rubber sealant (Conseal CS-102 or equal). Inside of joints shall be grouted with non-shrink grout.
7. When PVC is used, water stops shall be used. (i.e. Adapter rings).
8. Manhole Base. Refer to Standard Plan 207-AG.

REFERENCE:

- 207-AG Manhole Base
- 630-2 (APWA) 24" Manhole Frame and Cover
- 638-AG PCC Collar

CITY OF ARROYO GRANDE - ENGINEERING DEPARTMENT

STANDARD PLAN

ISSUE DATE:

**SEWER  
MANHOLE**

**200-AG**

APR 1, 2005

Don Spagnolo, P.E.  
Director of Public Works/City Engineer  
L.C.E. No. 42993

Sheet 1 of 1