

DECK DRAIN PIPE DETAIL (MOD) AT ABUT 1

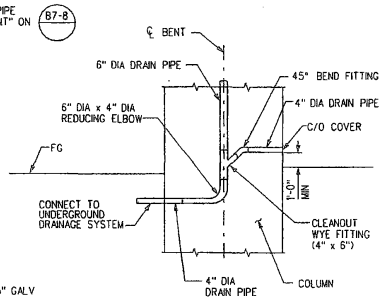

CLEANOUT DETAIL

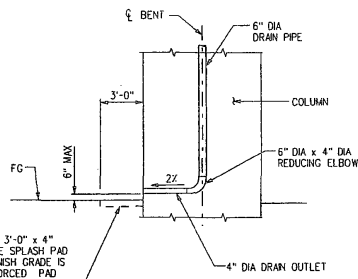

COLUMN DRAINAGE OUTLET DETAIL

PROVIDE 1'-6" x 3'-0" x 4" THICK CONCRETE SPLASH PAD IF ADJACENT FINISH GRADE IS UNPAVED. REINFORCED PAD WITH 6 x 6 - W2.9 x 2.9 WWF

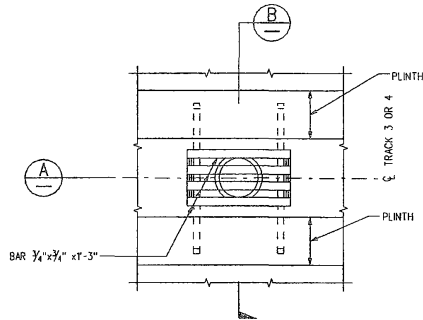

DECK DRAIN DETAIL

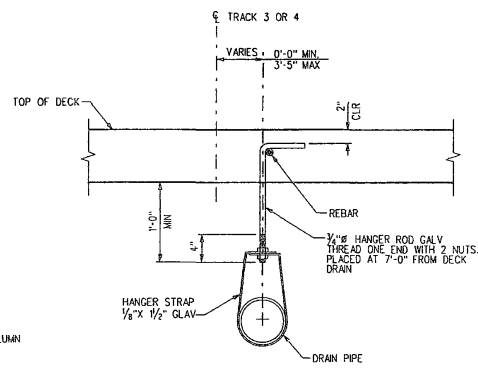

PIPE HANGER DETAILS

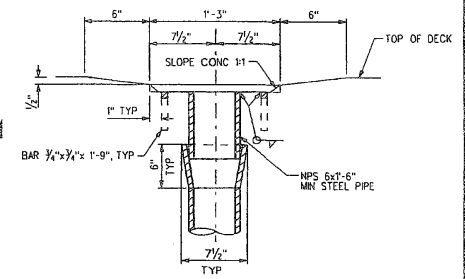

SECTION

A
 S-10-101

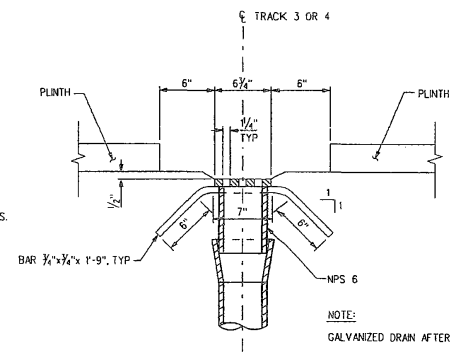

SECTION

B
 S-10-101

NOTE:

1. ALL PIPE TO BE NPS 6X0.135" WELDED STEEL PIPE EXCEPT AS NOTED AND GALVANIZED IF NOT ENCASED IN CONCRETE. FITTINGS AND BENDS SHALL HAVE A MINIMUM WALL THICKNESS OF 1/4". ALL JOINTS OR CONNECTIONS TO BE BUTT WELDED OR CONNECTED BY A STEEL PIPE SLEEVE. ALL BENDS TO BE ON A 1'-6" MINIMUM RADIUS MEASURED ALONG C/P. ALL BENDS TO BE SMOOTH.
2. PIPES TO BE SUPPORTED BY GALVANIZED PIPE HANGER AT 10'-0" MAXIMUM SPACING EXCEPT AS NOTED.

DESIGNED BY	S. LEE							
DRAWN BY	E. BALTAY							
CHECKED BY								
IN CHARGE	B. KNOETGEN							
DATE	12/8/08							
REV	DATE	BY	APP	REC NO	EXPIRES	SEA	HOLDER	DESCRIPTION

DESIGNED BY	S. LEE
DRAWN BY	E. BALTAY
CHECKED BY	
IN CHARGE	B. KNOETGEN
DATE	12/8/08

**EXPOSITION METRO LINE
 CONSTRUCTION AUTHORITY**

FCI/FLUOR/PARSONS

A JOINT VENTURE
 707 WILSHIRE BLVD, SUITE #3400
 LOS ANGELES, CALIFORNIA 90017

MID-CITY/EXPOSITION LRT PROJECT
 VENICE/ROBERTSON AERIAL STRUCTURE
 DECK DRAIN DETAILS
 SHEET 2 OF 2

CONTRACT NO	1-06
DRAWING NO	S-10-101
SCALE	NO SCALE
SHEET NO	