

**PLAN OF COVER**  
TOP VIEW

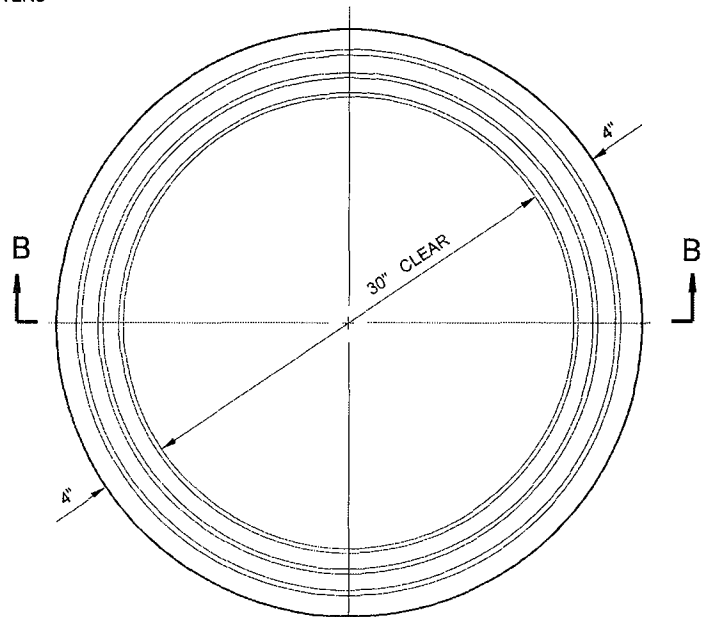

**PLAN OF FRAME**

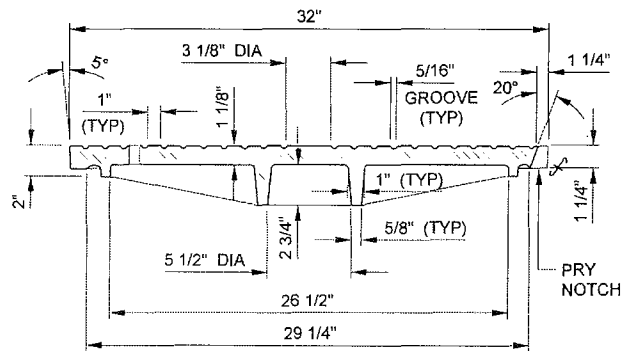

**SECTION A-A**

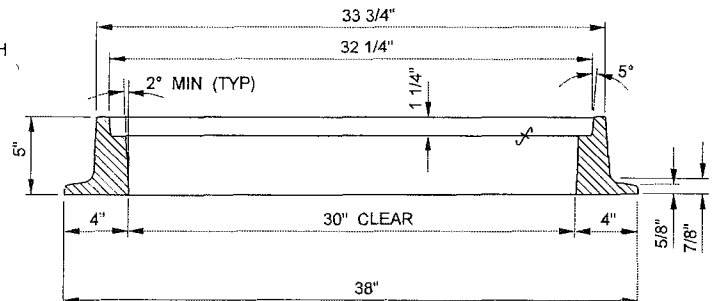

**SECTION B-B**

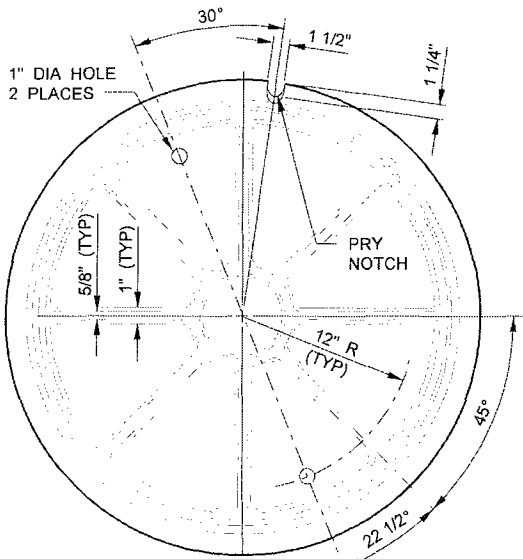

**PLAN OF COVER**  
BOTTOM VIEW

**NOTES:**

1. CAST IRON USED SHALL CONFORM WITH ASTM A-48 CLASS 35B.
2. FRAME AND COVER SHALL BE COATED WITH ASPHALTUM OR BITUMINOUS PAINT AFTER TESTING AND INSPECTION.
3. FRAME AND COVER SHALL BE TESTED FOR ACCURATE FIT PRIOR TO DELIVERY AND SHALL BE MARKED IN SETS.
4. ALL CASTINGS SHALL COMPLY WITH SECTION 208-3 OF THE STANDARD SPECIFICATIONS.

COUNTY SANITATION DISTRICTS OF LOS ANGELES COUNTY  
OFFICE OF CHIEF ENGINEER

STEPHEN R. MAGUIN  
CHIEF ENGINEER

**STANDARD 30" MANHOLE FRAME  
AND COVER**

STANDARD DRAWING  
2006 EDITION  
**S - a - 2 2 3**  
SHEET 1 OF 1