

DIST	COUNTY	ROUTE	POST MILES TOTAL PROJECT	SHEET NO.	TOTAL SHEETS

Mark S. Turner
 PROFESSIONAL LAND SURVEYOR
 LICENSE NO. 6228
 Exp. 3-31-08
 STATE OF CALIFORNIA

May 1, 2006
 PLANS APPROVAL DATE
 The State of California or its officers or agents shall not be responsible for the accuracy or completeness of electronic copies of this plan sheet.
 To get to the Caltrans web site, go to: <http://www.dtd.ca.gov>

2006 STANDARD PLAN A74

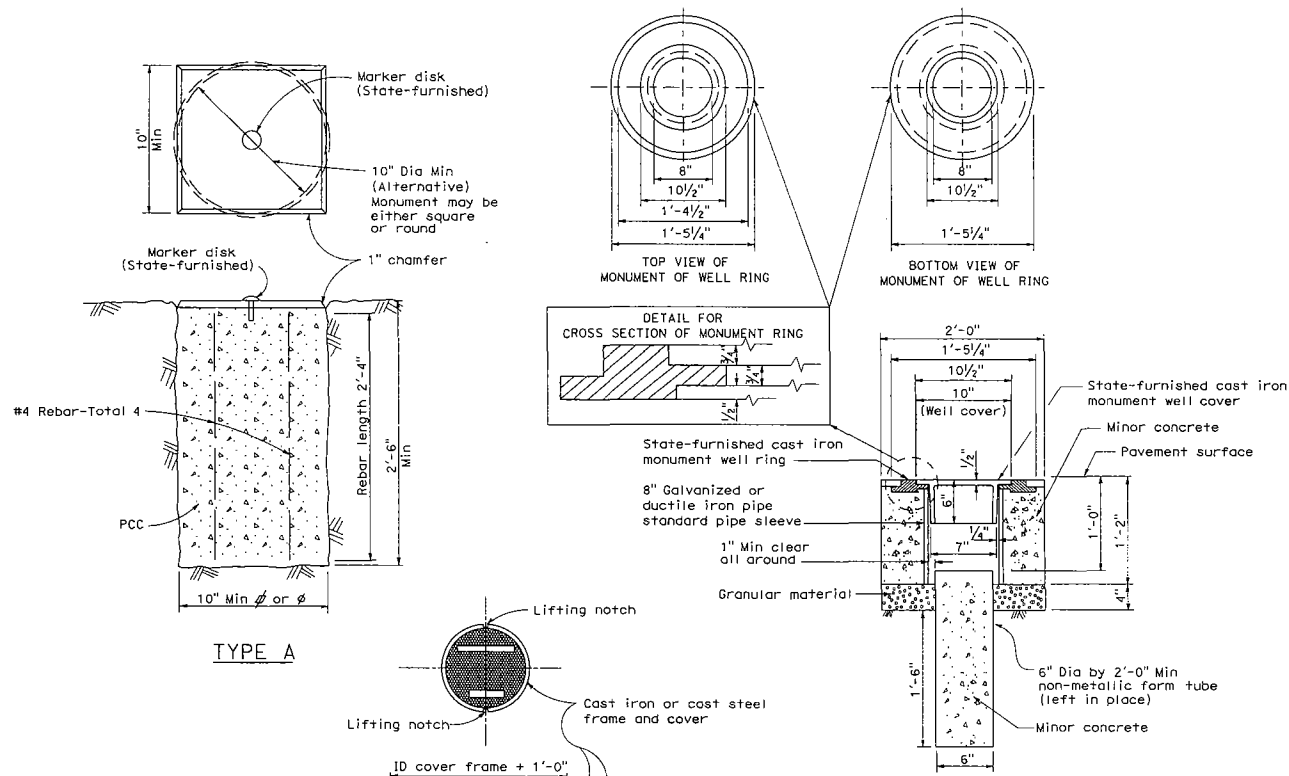

NOTES:

1. The configuration of the cast iron or cast steel frame and cover may vary from that shown.
2. Frame shall be embedded in the concrete a minimum of 3".
3. Type D monument shall be either Alternative No. 1 or Alternative No. 2 at the contractor's option.
4. All portland cement concrete shall be Class 2 or minor concrete with 1" maximum aggregate.

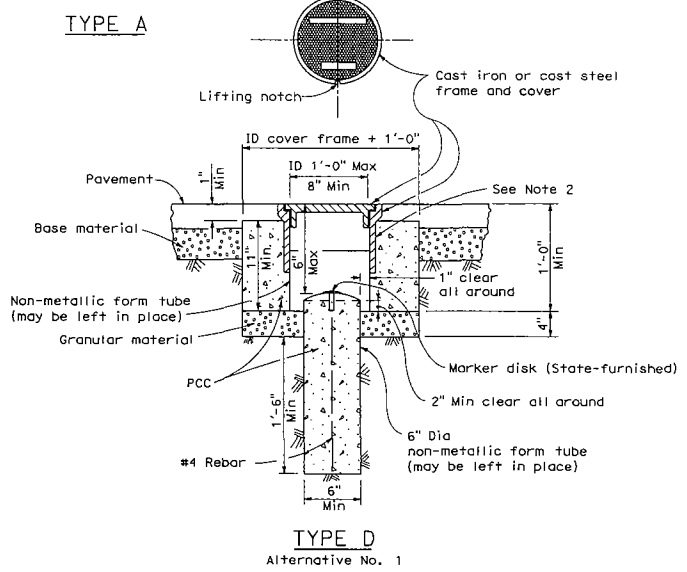
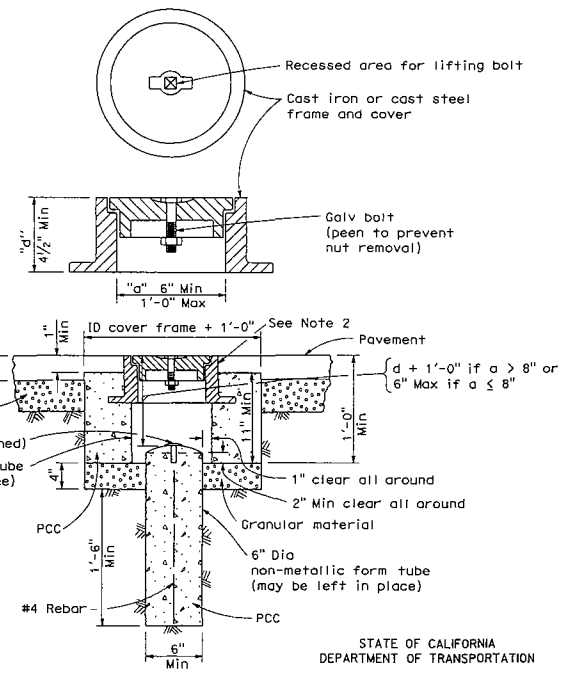

TYPE D
 Alternative No. 2

STATE OF CALIFORNIA
 DEPARTMENT OF TRANSPORTATION
SURVEY MONUMENTS
 NO SCALE

A74