

**PLAN  
THROUGH MANHOLE**

**PLAN  
INTERSECTING MANHOLE**

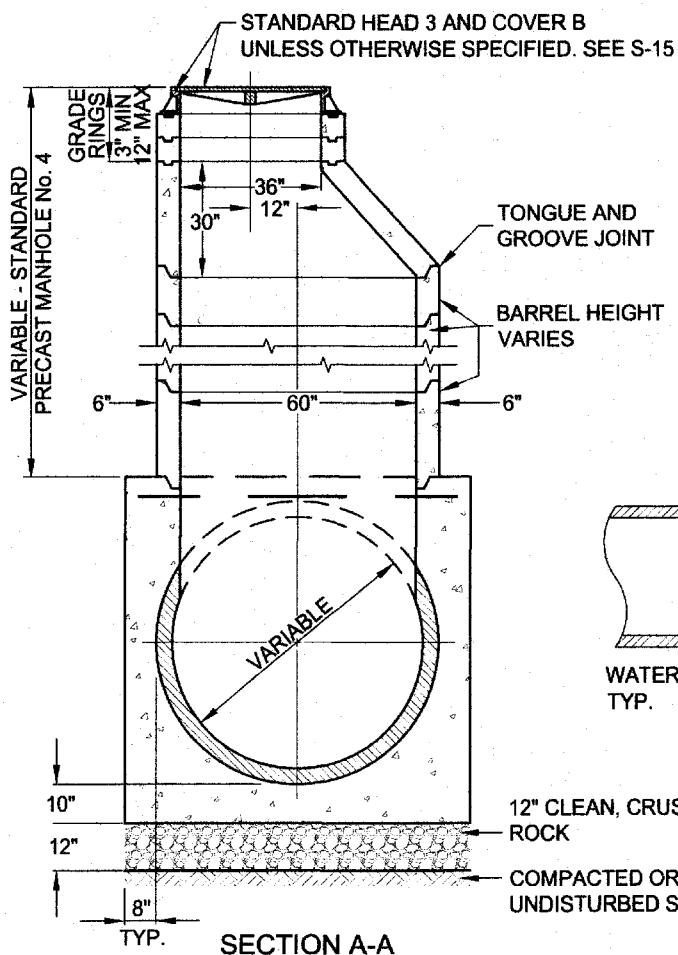

**SECTION A-A**

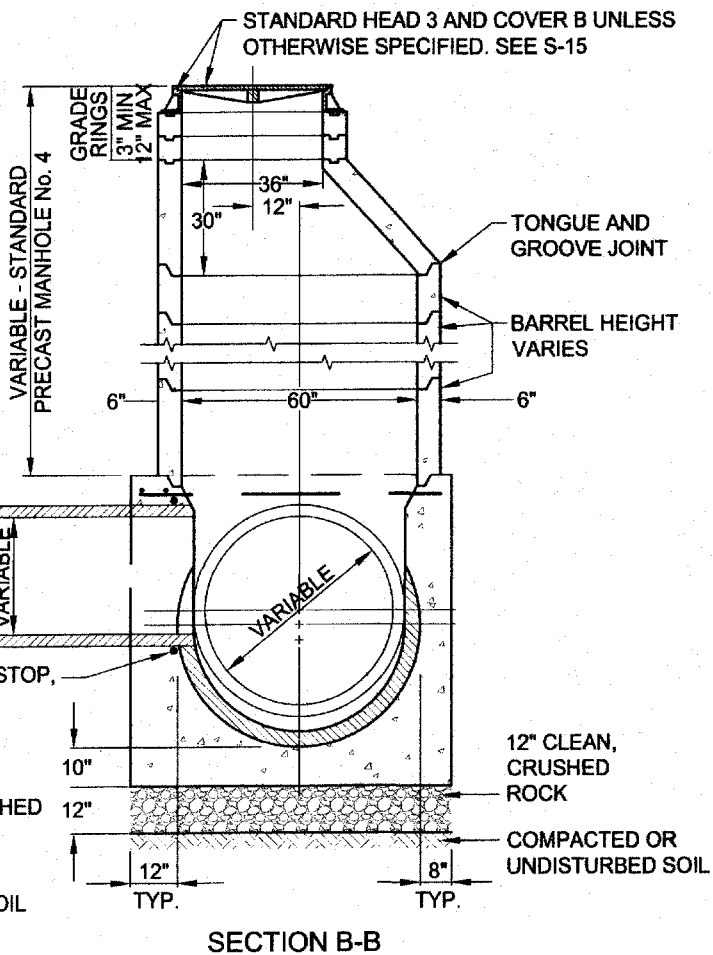

**SECTION B-B**

**NOTE**

1. USE SADDLE TYPE MANHOLE ON STORM DRAIN AND SANITARY SEWER LINES LARGER THAN 42 INCHES IN DIAMETER OR AS DIRECTED BY ENGINEER.

REV.	DATE	DESCRIPTION

R:\Utilistas\City\_Std\_Details\Sewer\_Drainage\S\_120\_SaddleTypeManhole.dwg