

PIPE ID (INCHES)	PIPE OD (INCHES)	ACCESS CONTROL RACK		VARIABLE DIMINIONS															
				SLOPE = 1:1				SLOPE = 1.5:1				SLOPE = 2:1				SLOPE = 3:1			
				W	H	X	Y	Z	K	X	Y	Z	K	X	Y	Z	K	X	Y
12	16.5	12	12	4'-6"	4'-6"	4'-8"	6"	3'-0"	4'-6"	4'-8"	6"	2'-10"	5'-9"	4'-8"	1'-2"	2'-10"	8'-8"	4'-8"	2'-6"
15	19.5	15	15	5'-0"	5'-0"	5'-10"	6"	3'-4"	5'-0"	5'-10"	6"	3'-2"	6'-3"	5'-10"	1'-2"	3'-2"	9'-4"	5'-10"	2'-8"
18	23	18	18	5'-6"	5'-6"	7'-0"	6"	3'-8"	5'-6"	7'-0"	6"	3'-6"	6'-8"	7'-0"	1'-2"	3'-6"	10'-3"	7'-0"	2'-10"
21	27	21	21	6'-0"	6'-0"	8'-2"	6"	4'-0"	6'-0"	8'-2"	6"	3'-9"	7'-6"	8'-2"	1'-3"	3'-9"	11'-3"	8'-2"	3'-2"
24	31.5	24	24	6'-6"	6'-6"	9'-4"	6"	4'-4"	6'-6"	9'-4"	6"	4'-2"	8'-3"	9'-4"	1'-4"	4'-2"	12'-4"	9'-4"	3'-5"
27	35	27	27	7'-0"	7'-0"	10'-6"	6"	4'-8"	7'-0"	10'-6"	6"	4'-9"	8'-10"	10'-6"	1'-5"	4'-9"	13'-3"	10'-6"	3'-8"
30	38.5	30	30	7'-6"	7'-6"	11'-8"	6"	5'-0"	7'-6"	11'-8"	6"	5'-3"	9'-6"	11'-8"	1'-6"	5'-3"	14'-2"	11'-8"	3'-10"
36	45.5	36	36	8'-5"	8'-5"	14'-0"	6"	5'-8"	8'-5"	14'-0"	6"	8'-5"	10'-7"	14'-0"	1'-7"	8'-5"	15'-10"	14'-0"	4'-2"
42	52.5	42	42	9'-6"	9'-6"	16'-4"	6"	6'-4"	9'-6"	16'-4"	6"	5'-10"	11'-9"	16'-4"	1'-8"	5'-10"	17'-8"	16'-4"	4'-6"
58	59	48	48	10'-6"	10'-6"	18'-8"	6"	7'-0"	10'-6"	18'-8"	6"	6'-6"	12'-10"	18'-8"	1'-8"	6'-6"	19'-3"	18'-8"	4'-10"
54	66	60	60	11'-6"	11'-6"	21'-0"	6"	7'-8"	11'-6"	21'-0"	6"	7'-0"	14'-0"	21'-0"	1'-9"	7'-0"	21'-0"	21'-0"	5'-3"
60	72	60	60	12'-6"	12'-6"	23'-4"	6"	8'-4"	12'-6"	23'-4"	6"	7'-6"	15'-0"	23'-4"	1'-9"	7'-6"	22'-6"	23'-4"	5'-6"
66	78	66	66	13'-6"	13'-6"	25'-8"	6"	9'-0"	13'-6"	25'-8"	6"	8'-0"	16'-0"	25'-8"	1'-9"	8'-0"	24'-0"	25'-8"	5'-9"
72	84	72	72	14'-6"	14'-6"	28'-0"	6"	9'-8"	14'-6"	28'-0"	6"	8'-6"	17'-0"	28'-0"	1'-9"	8'-6"	25'-6"	28'-0"	6'-0"

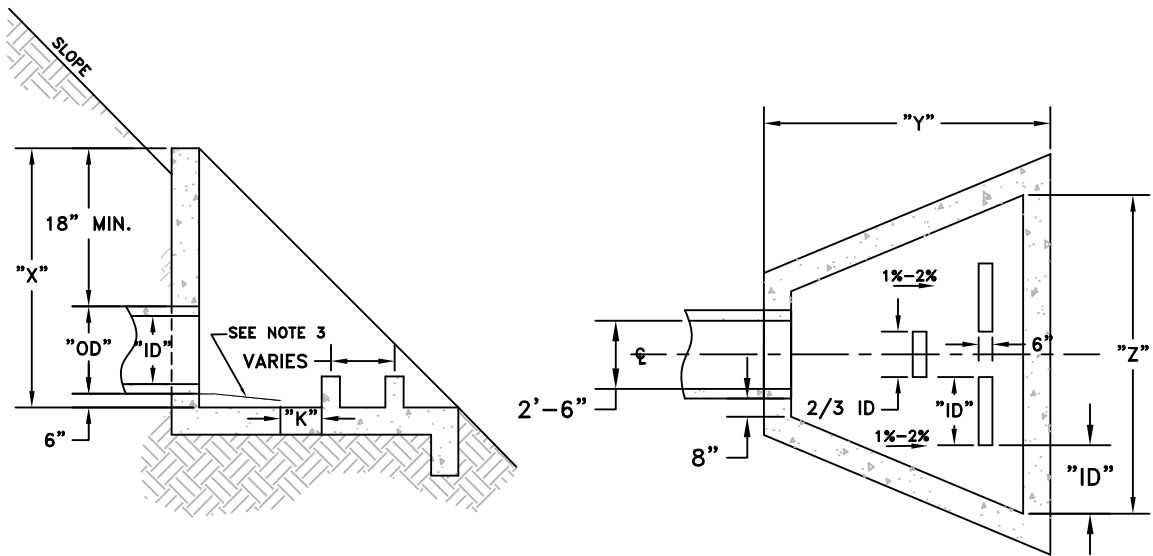

  
**ROB JENSEN**  
 DIRECTOR OF PUBLIC WORKS/CITY ENGINEER

 DEPARTMENT OF PUBLIC WORKS

## HEADWALL

**NOTES:**

1. STRUCTURAL CALCULATIONS SHALL BE SUBMITTED FOR HEADWALL.
2. ALL CONCRETE TO BE CLASS "A" 6-SACK
3. REFER TO "CST DR-14" FOR ACCESS CONTROL RACK.

SCALE: NONE  
 REVISED: MARCH 2007  
 DRAWN BY: STAFF  
 APPROVED BY: R JENSEN

DR-12