

2" [51mm] RAISED LETTERS  
(RECESSED FLUSH)  
FLAT FACE GOTHIC NO. 2

2 1/2" [64mm] RAISED  
LETTERS (RECESSED FLUSH)  
FLAT FACE GOTHIC NO. 2

3/4" [19mm] DIA  
HANDLING HOLE

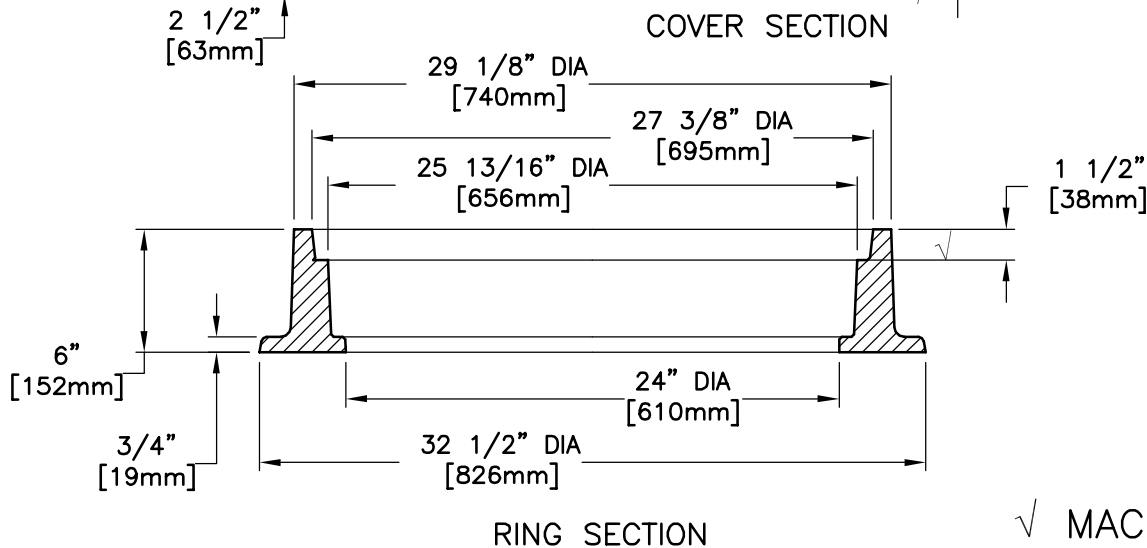
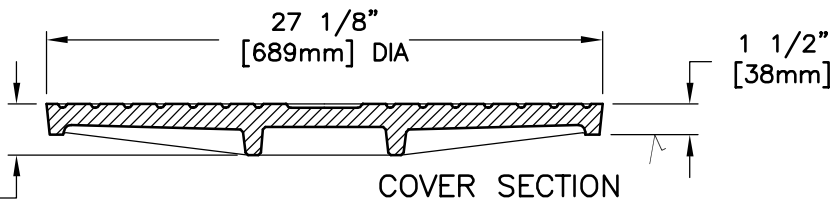

✓ MACHINED SURFACE

EAST JORDAN  
IRON WORKS, INC.  
P.O. BOX 439  
EAST JORDAN, MI. 49727  
1-800-874-4100  
FAX 231-536-4458

DRAWN SBB	DATE 05/15/03
--------------	------------------

APPROVED	DATE
----------	------

MANHOLE  
ASSEMBLY  
(LBIW X162)

PRODUCT NO.

**00316205**

CATALOG NO.

3162C  
3162Z

REF. PRODUCT DRAWING  
316225  
316210

EST. WT.

COVER: 175 LBS 79kg  
FRAME: 265 LBS 120kg  
UNIT: 440 LBS 199kg

OPEN AREA

N/A

MAT'L SPEC.

COVER - GRAY IRON  
ASTM A48 CL35  
FRAME - GRAY IRON  
ASTM A48 CL35

LOAD RATING

HEAVY DUTY