

SEPTEMBER 2001

STANDARD 151-1 (FROM AMERICAN PUBLIC WORKS ASSOCIATION) REPLACES STANDARD 410 AND 411.

**PER TOM BOYD
INTERIM PUBLIC WORKS DIRECTOR**

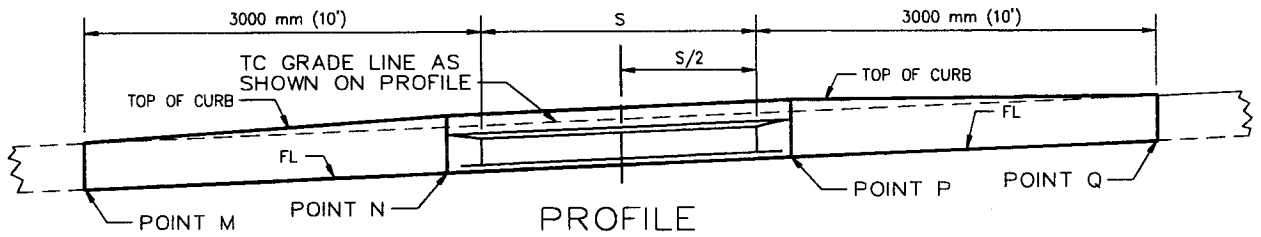
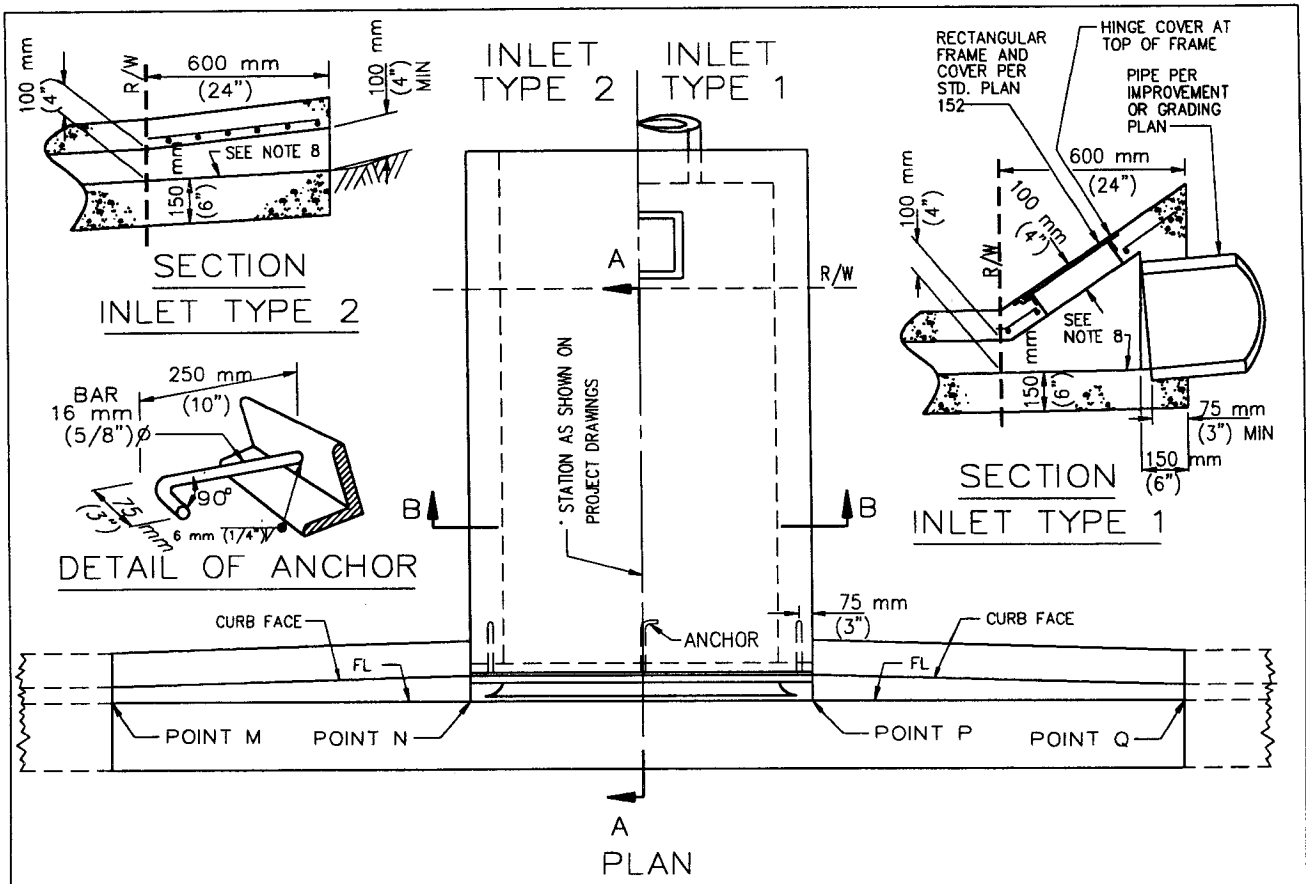

S, mm	J BAR SPACING, mm
300 (12")	240 (7")
450 (18")	240 (7")
600 (24")	240 (7")
750 (30")	240 (7")
900 (36")	240 (7")
1050 (42")	210 (6")
1200 (48")	180 (5")
1350 (54")	225 (6-1/2")
1500 (60")	180 (5")
1650 (66")	180 (4")
1800 (72")	120 (3-1/2")

FOR S = 750 mm (30") AND LESS, USE 2 ANCHORS. OTHERWISE, USE 3 ANCHORS.

FOR S = 1200 mm (48") AND LESS, B = 75 mm (3")
USE 64x51x9.5 (2-1/2"x2"x3/8") GALVANIZED STEEL ANGLE.

OTHERWISE, B = 100 mm (4"). USE 89x76x12.7 (3-1/2"x3"x1/2") GALVANIZED STEEL ANGLE.

J BARS ARE #10M (#3).

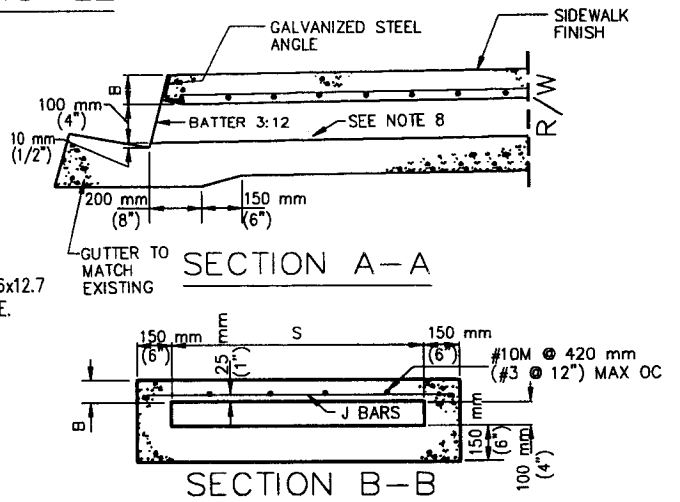

AMERICAN PUBLIC WORKS ASSOCIATION - SOUTHERN CALIFORNIA CHAPTER		
PROMULGATED BY THE PUBLIC WORKS STANDARDS INC. GREENBOOK COMMITTEE 1993 REV. 1996	<h2 style="margin: 0;">PARKWAY DRAIN</h2>	STANDARD PLAN METRIC <h1 style="margin: 0;">151 - 1</h1>
USE WITH STANDARD SPECIFICATIONS FOR PUBLIC WORKS CONSTRUCTION		SHEET 1 OF 2

NOTES

1. FLOOR OF BOX SHALL BE TROWLED SMOOTH.
2. IF THE TOE OF SLOPE IS ALLOWED WITHIN THE R/W, INLET TYPE 1 BEGINS AT THE TOE RATHER THAN AT THE R/W LINE.
3. FOR OPEN DITCH (TYPE 2), THE 600 mm (24") EXTENSION BEYOND THE R/W LINE IS NOT REQUIRED WHEN BACK OF WALK IS 600 mm (24") OR MORE FROM THE R/W LINE; HOWEVER, THE PIPE SHALL EXTEND TO THE R/W LINE IN ANY EVENT.
4. TOP OF INLET STRUCTURE (TYPE 1 & 2) SHALL BE FLUSH WITH ADJACENT SURFACE WHERE PRACTICAL.
5. A HEADED STEEL STUD 16 mm x 160 mm WITH A 25 mm HEAD (5/8" x 6-3/8", 1" HEAD) ATTACHED BY A FULL PENETRATION BUTT WELD MAY BE USED AS AN ALTERNATE ANCHOR.
6. NORMAL CURB FACE AT POINT M AND Q. CURB FACE IS B + 125 mm (5") AT POINT N AND P.
7. THE 75 mm (3") LEG OF THE 16 mm (5/8") DIA ANCHORS SHALL BE PARALLEL TO THE TOP OF SIDEWALK.
8. SLOPE = 2.0%.
9. DIMENSIONS SHOWN ON THIS PLAN FOR METRIC AND ENGLISH UNITS ARE NOT EXACTLY EQUAL VALUES. IF METRIC UNITS ARE USED, ALL VALUES USED FOR CONSTRUCTION SHALL BE METRIC VALUES. IF ENGLISH UNITS ARE USED, ALL VALUES USED FOR CONSTRUCTION SHALL BE ENGLISH VALUES. HOWEVER, ASTM 615 REINFORCING STEEL MAY BE SUBSTITUTED FOR ASTM 615M STEEL.

AMERICAN PUBLIC WORKS ASSOCIATION - SOUTHERN CALIFORNIA CHAPTER

PARKWAY DRAIN

STANDARD PLAN
METRIC

151 - 1
SHEET 2 OF 2