

LBIW Inc.
 2020 WEST 14TH STREET
 LONG BEACH, CA. 90813
 Tel No. : (562) 432.5451
 Fax No. : (562) 432.5929
 www.lbiw.com

PRODUCT NUMBER

LB S-342

LOAD RATING
 BICYCLE FRIENDLY
 TRAFFIC RATED

COATING

GALVANIZED

EST. WEIGHT

FRAME	135 IBS
GRATE	225 IBS
TOTAL WT.	360 IBS

SPECIFICATION

COLA DEPARTMENT OF
 PUBLIC WORKS S-342-4

OPEN AREA

DESIGNATES MACHINED

DRAWN

DATE

EB

02-06-09

REVISED

DATE

04-21-09

REFERENCE INFORMATION

SHEET 1 OF 2

SECTION 07



LBIW Inc.

2020 WEST 14TH STREET
LONG BEACH, CA. 90813
Tel No. : (562) 432.5451
Fax No. : (562) 435.5929

www.lbiw.com

PRODUCT NUMBER
LB S-342
STEEL GRATE
BICYCLE FRIENDLY

LOAD RATING
TRAFFIC RATED

SPECIFICATIONS
MATERIAL : ASTM A36
COATING : ASTM A123
(GALVANIZING)

MADE IN USA

EST. WEIGHT

±235 LBS

STANDARD PLAN REFERENCE
COLA DEPARTMENT OF
PUBLIC WORKS S-342-4

DRAWN	DATE
EB	12-23-10
REVISED	DATE
05-05-15	

REFERENCE INFORMATION

LBIW CATALOG
SECTION 07

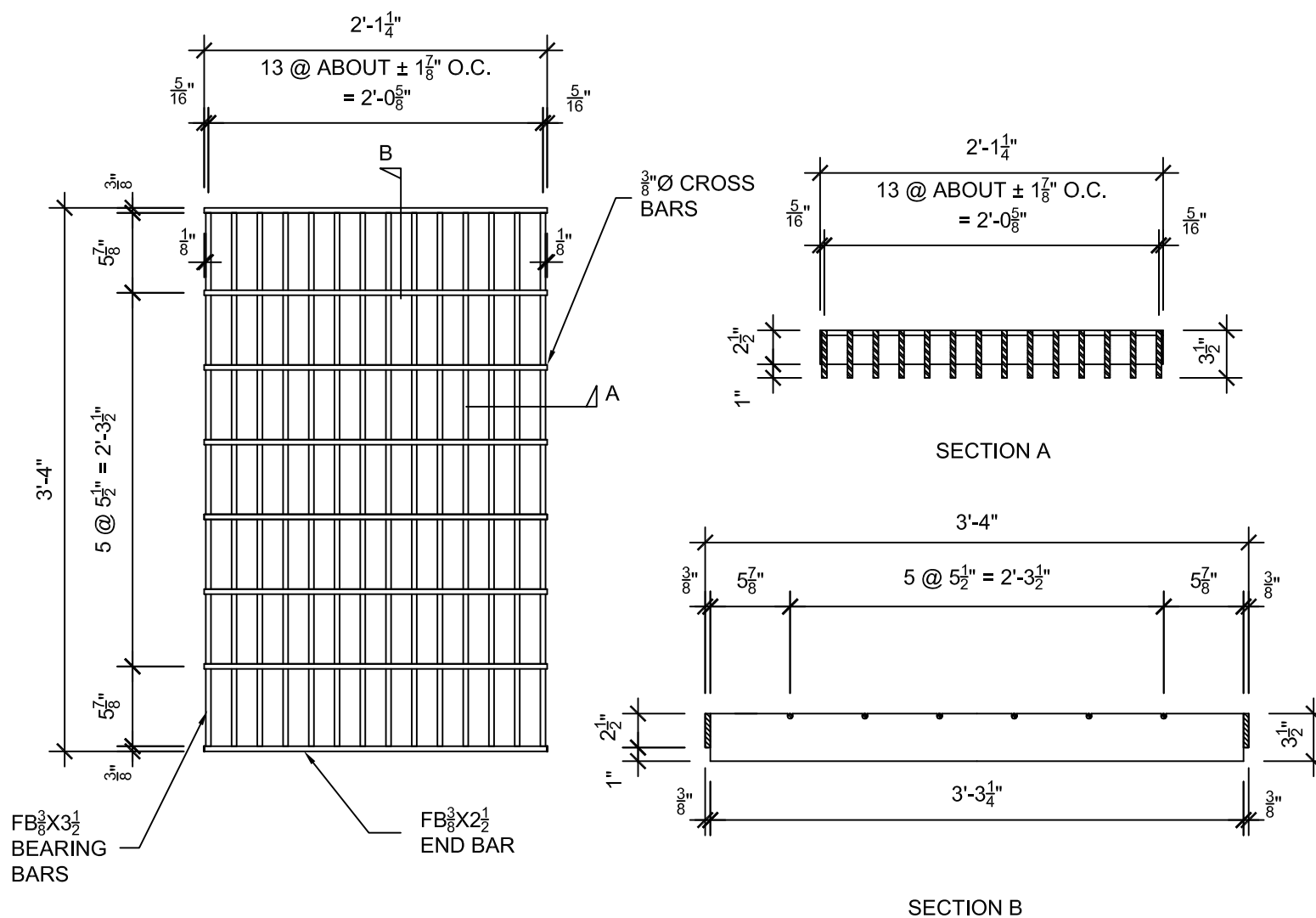

LB S-342 GRATE