

NEENAH R4999-DA FOUNDRY DUCTILE IRON TRENCH GRATE & ANGLE FRAME. GRATE TO BE BOLTED TO FRAME & CONSTRUCTED IN ACCORDANCE WITH MANUFACTURER'S RECOMMENDATIONS

**DRAFT**

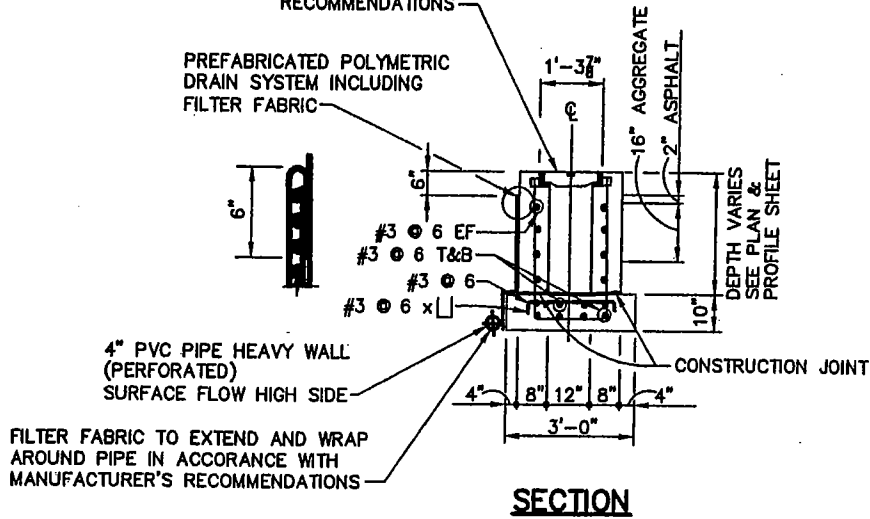

**NOTES:**

1. PREFABRICATED DRAIN SYSTEM 4" PERFORATED PVC PIPE SHALL BE PLACED ON THE HIGH SIDE OF ALL TRENCH DRAINS AND FOLLOW THE FLOW LINE OF TRENCH DRAIN.
2. CONCRETE SHALL BE CLASS 560-C-3250 WITH A MAXIMUM SLUMP OF 5", FC'=3250 P.S.I. COMPRESSIVE STRENGTH AT 28 DAYS, UNLESS OTHERWISE NOTED ON THE CONTRACT PLANS, REINFORCING STEEL IF REQUIRED SHALL BE DEFORMED REBARS WITH Fy EXCEEDING 60,000 PSI, ASTM A615 AND ASTM A706, GRADE 60. PLACING OF REINFORCEMENT AND SPLICING LENGTHS SHALL CONFORM TO ACI CODES 318-13.

**TYPICAL CONCRETE TRENCH DRAIN DETAIL**

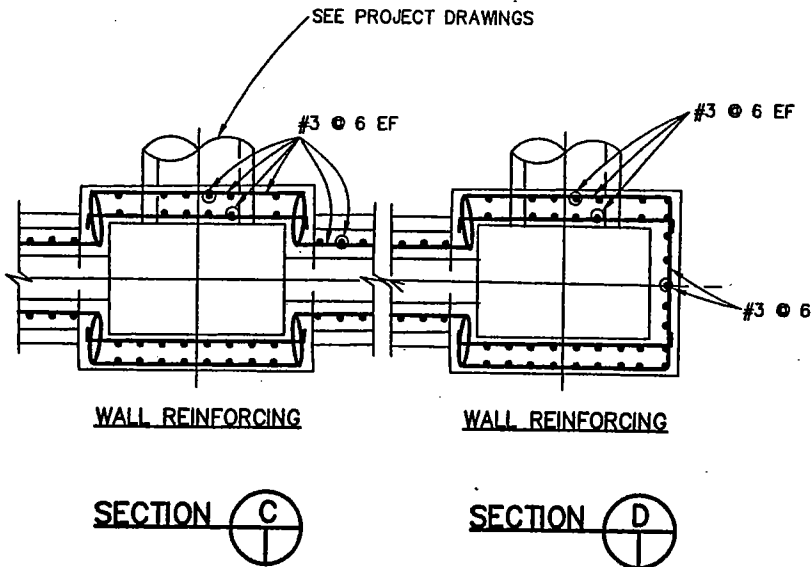

**THE PORT OF LONG BEACH** ENGINEERING DIVISION

REVISIONS	
NO.	DATE
1	
2	
3	

**TRENCH DRAIN**

APPROVED BY: \_\_\_\_\_ CHIEF HARBOR ENGINEER      R.E. NO.: \_\_\_\_\_      DATE: \_\_\_\_\_

STANDARD PLAN
D-8
2 OF 3