



LBIW Inc.

2020 WEST 14TH STREET
LONG BEACH, CA. 90813
Tel No. : (562) 432.5451
Fax No. : (562) 435.5929

www.lbiw.com

PRODUCT NUMBER
APWA 305

STEEL FRAME
2 GRATES

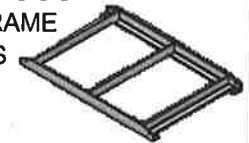

LOAD RATING

SPECIFICATIONS

MATERIAL : ASTM A36
COATING : ASTM A123
(GALVANIZING)

MADE IN USA

EST. WEIGHT

LBS

STANDARD PLAN REFERENCE

*APWA 311-3
*APWA 305-3

DRAWN

EB

REVISED

DATE

04-05-17

DATE

REFERENCE INFORMATION

LBIW CATALOG
SECTION 07

REVISED 2016 EB

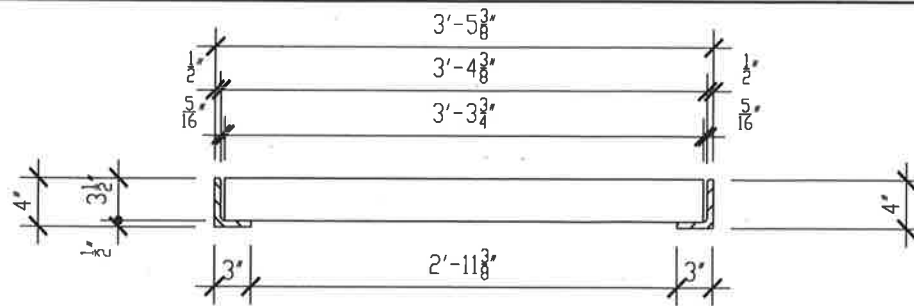

SECTION B-B

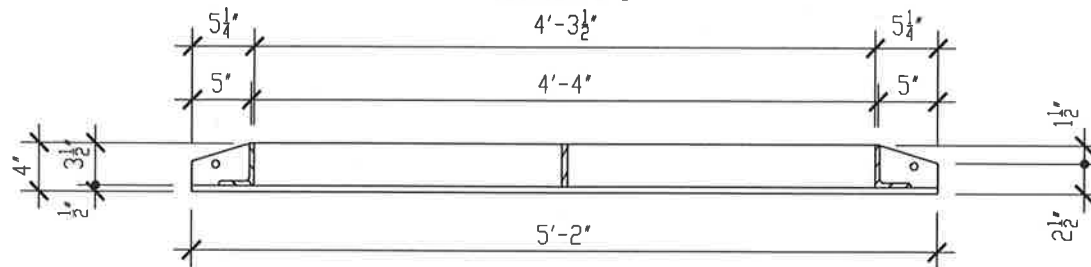

SECTION A-A

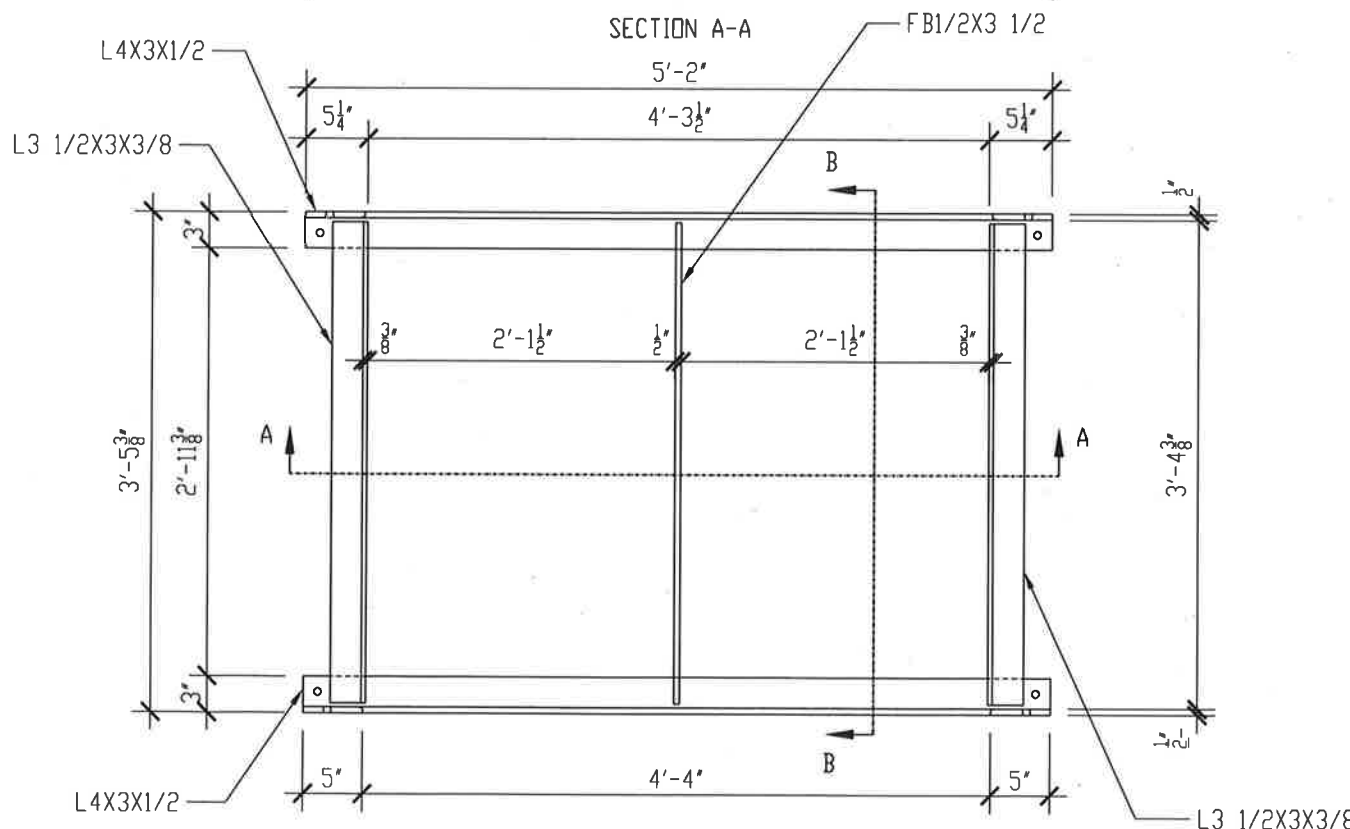

APWA 305 2 GRATES



LBIW Inc.

2020 WEST 14TH STREET
LONG BEACH, CA. 90813
Tel No. : (562) 432.5451
Fax No. : (562) 435.5929

www.lbiw.com

PRODUCT NUMBER

APWA 305

STEEL FRAME

3 GRATES



LOAD RATING

SPECIFICATIONS

MATERIAL : ASTM A36

COATING : ASTM A123

(GALVANIZING)

MADE IN USA

EST. WEIGHT

LBS

STANDARD PLAN REFERENCE

*APWA 311-3

*APWA 305-3

DRAWN

DATE

EB

04-05-17

REVISED

DATE

REFERENCE INFORMATION

LBIW CATALOG

SECTION 07

REVISED 2016 EB

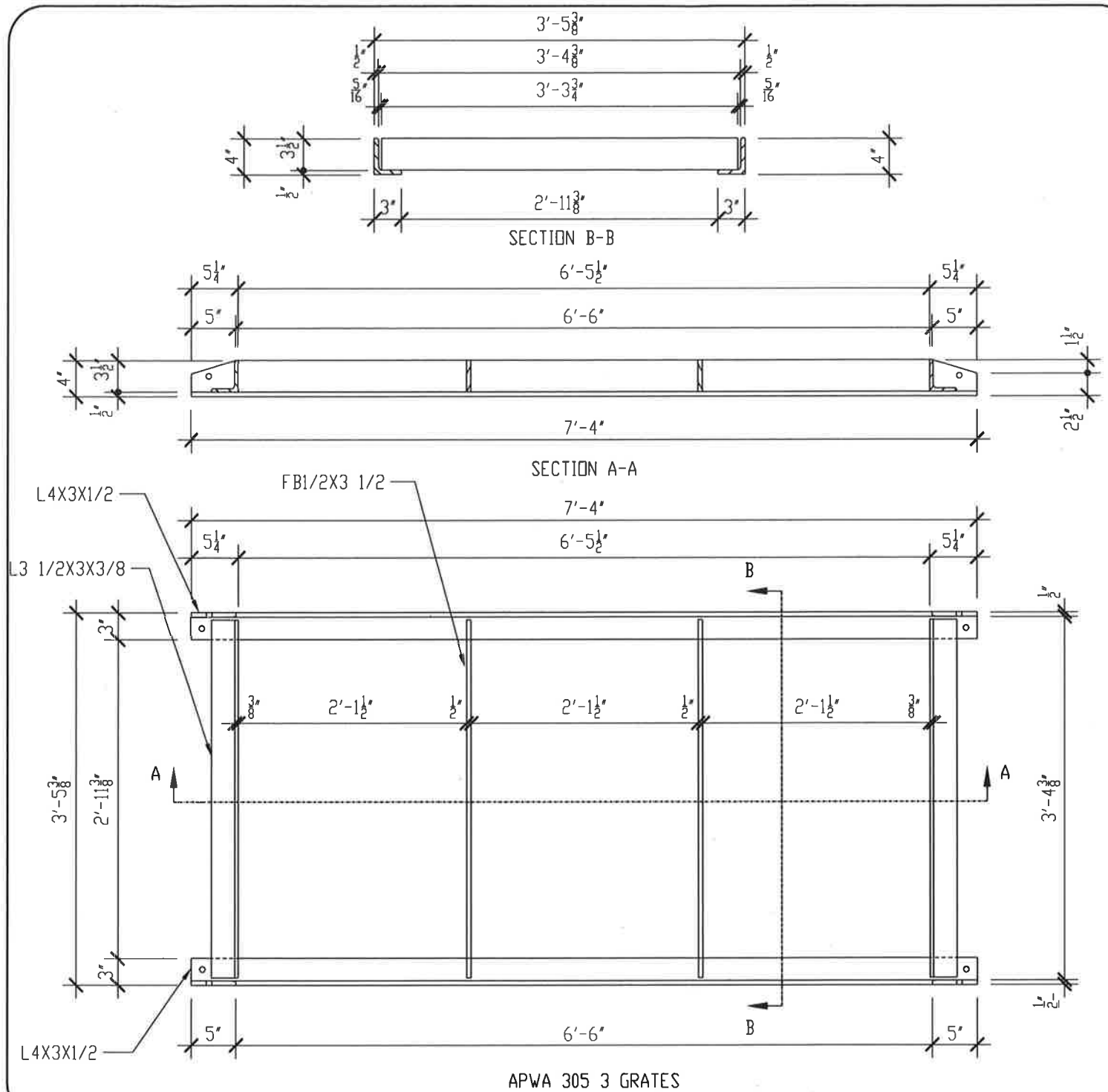



LBIW Inc.

2020 WEST 14TH STREET
LONG BEACH, CA. 90813
Tel No. : (562) 432.5451
Fax No. : (562) 435.5929

www.lbiw.com

PRODUCT NUMBER

APWA 305

STEEL FRAME
4 GRATES

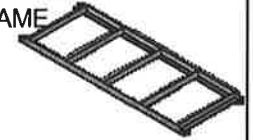

LOAD RATING

SPECIFICATIONS

MATERIAL : ASTM A36
COATING : ASTM A123
(GALVANIZING)

MADE IN USA

EST. WEIGHT

LBS

STANDARD PLAN REFERENCE

*APWA 311-3
*APWA 305-3

DRAWN

DATE

EB

04-05-17

REVISED

DATE

REFERENCE INFORMATION

LBIW CATALOG
SECTION 07

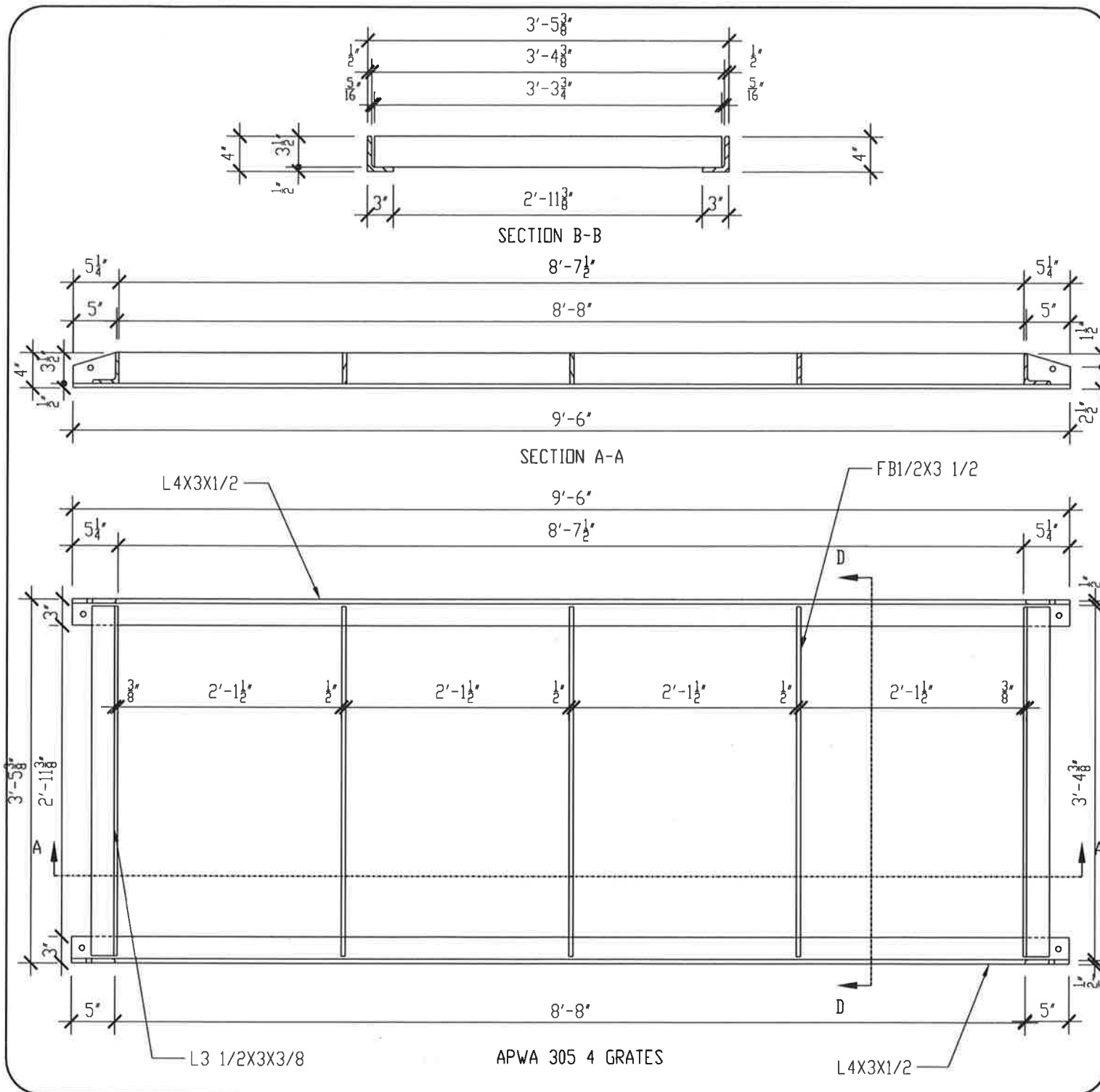



LBIW Inc.

2020 WEST 14TH STREET
LONG BEACH, CA. 90813
Tel No. : (562) 432.5451
Fax No. : (562) 435.5929

www.lbiw.com

PRODUCT NUMBER

LB 319A

STEEL
FRAME

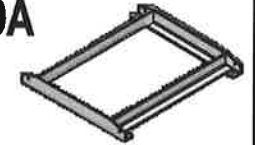

LOAD RATING

SPECIFICATIONS

MATERIAL : ASTM A36
COATING : ASTM A123
(GALVANIZING)
: MILL FINISH
(UNCOATED)

MADE IN USA

EST. WEIGHT

± 120 LBS

STANDARD PLAN REFERENCE

*APWA 311-3
*APWA 301-3 TO 304-3

DRAWN

DATE

EB

03-27-09

REVISED

DATE

04-04-17

REFERENCE INFORMATION

LBIW CATALOG
SECTION 07

REVISED 2016 EB

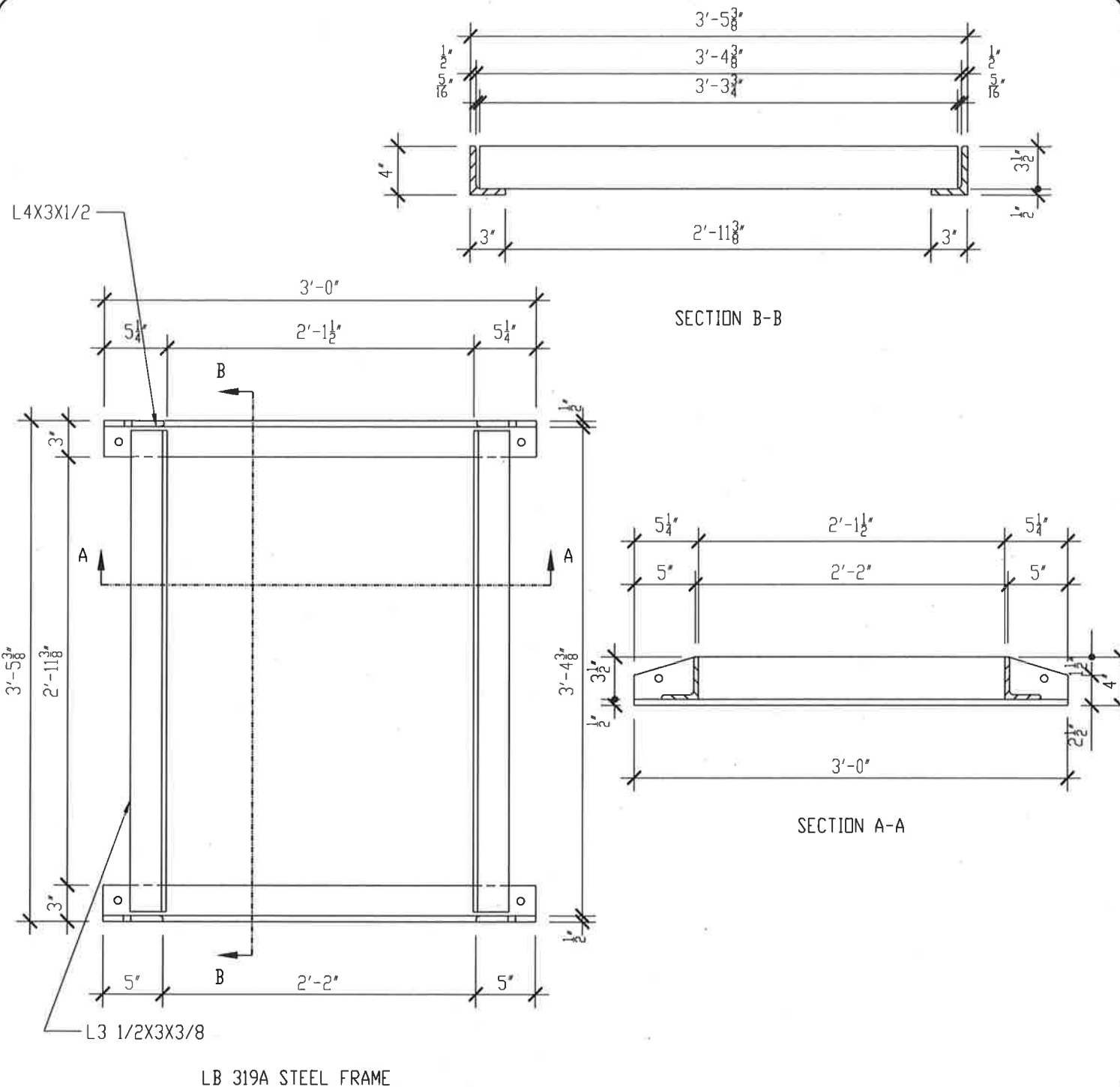



LBIW Inc.

2020 WEST 14TH STREET
LONG BEACH, CA. 90813
Tel No.: (562) 432.5451
Fax No.: (562) 435.5929

www.lbiw.com

PRODUCT NUMBER

LB 319A

STEEL
GRATE

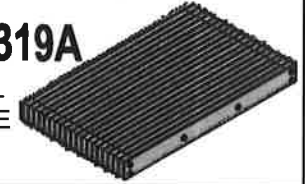

LOAD RATING

TRAFFIC RATED

SPECIFICATIONS

MATERIAL : ASTM A36
COATING : ASTM A123
(GALVANIZING)
: MILL FINISH
(UNCOATED)

MADE IN USA

EST. WEIGHT

± 445 LBS

STANDARD PLAN REFERENCE

*APWA 311-3
*APWA 301-3 TO 304-3
*APWA 305-3

DRAWN

EB

04-04-17

DATE

06-18-10

DATE

REFERENCE INFORMATION

LBIW CATALOG
SECTION 07

REVISED 2016 EB

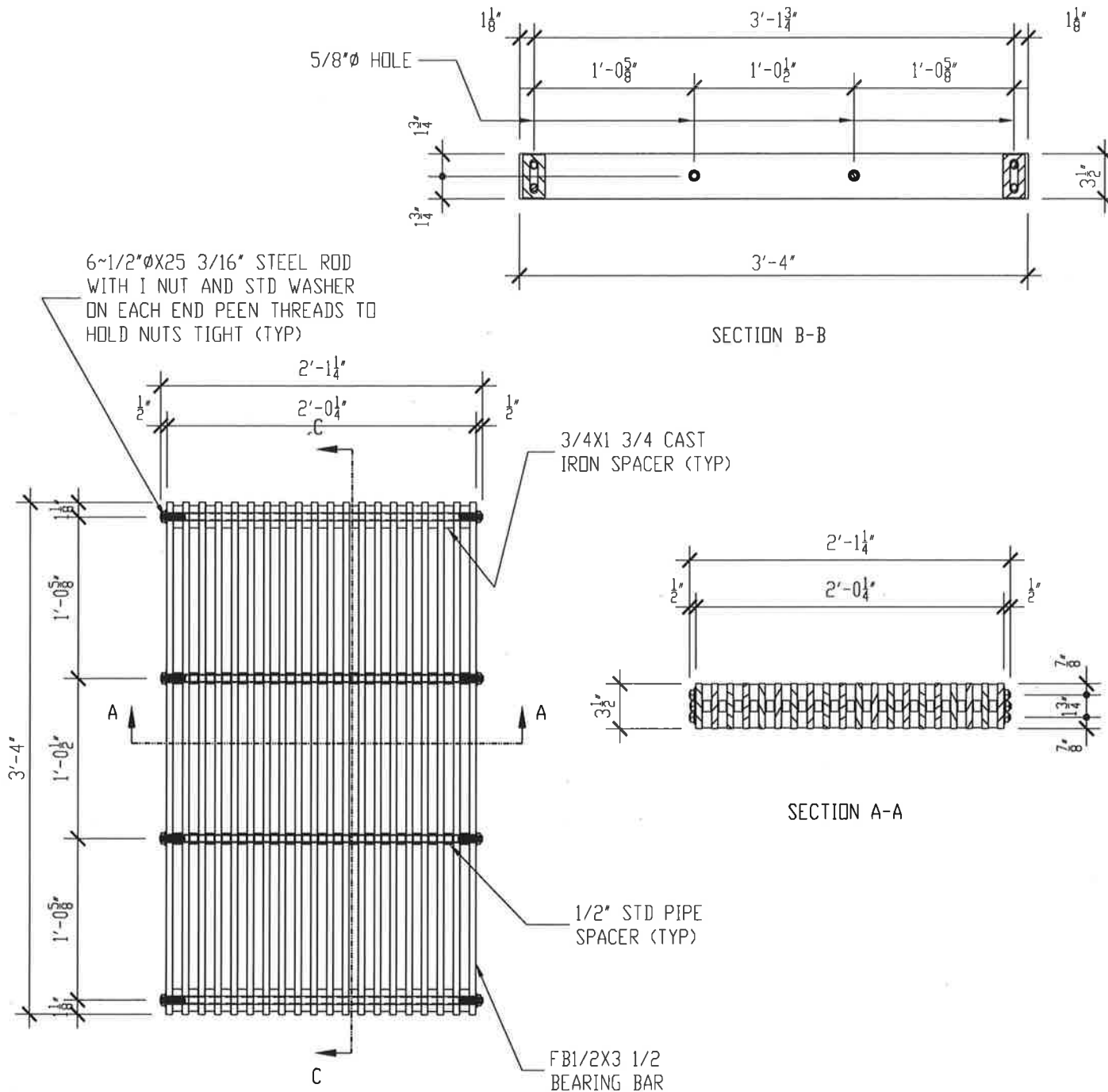

LB 319A RECTANGULAR GRATE