

# STANDARD PLANS

---

MAY, 1992

**INDEX**  
**STANDARD PLANS**

**SECTION A - STREET AND SURFACE IMPROVEMENTS**

A-1	"V" GUTTER
A-2	ALLEY CONSTRUCTION REQUIREMENTS
A-3	CURBS AND GUTTER
A-4	SIDEWALK
A-5-1	SIDEWALK RAMP AND CORNER DETAIL
A-5-2	SIDEWALK RAMP AND CORNER DETAIL
A-6	CROSS GUTTER
A-7	RESIDENTIAL DRIVEWAY
A-8-1	COMMERCIAL DRIVEWAY
A-8-2	COMMERCIAL DRIVEWAY
A-9	PAVEMENT TO CURB TRANSITION
A-10	SIDEWALK TRANSITION DETAIL
A-11	STREET NAME AND TRAFFIC SIGNS
A-12-1	STOP SIGN AND PAVEMENT MARKINGS
A-12-2	LIMIT LINE PLACEMENT
A-13-1	STREET LIGHT POLE INSTALLATION
A-13-2	STREET LIGHT POLE INSTALLATION NOTES
A-14	STREET BARRICADE
A-15	MONUMENT

**SECTION B. WATER SYSTEM**

B-1	FIRE HYDRANT ASSEMBLY
B-2	STANDARD WATER VALVE
B-3	WATER SERVICE
B-4-1	BACKFLOW PREVENTION ASSEMBLY FOR FIRE PREVENTION SYSTEM
B-4-2	BACKFLOW PREVENTION ASSEMBLY FOR FIRE PREVENTION SYSTEM
B-5	BACKFLOW PREVENTION ASSEMBLY ENCLOSURE FOR FIRE PREVENTION SYSTEM
B-6	WATER TIE-IN W/VALVE CLUSTER
B-7	WATER MAIN VERTICAL OFFSET
B-8	AIR AND VACUUM COMBINATION RELEASE VALVE ASSEMBLY
B-9-1	BLOW OFF VALVE ASSEMBLY
B-9-2	BLOW OFF ASSEMBLY
B-10	BYPASS CONNECTION TO NEW MAINS
B-11	THRUST BLOCK DETAIL
B-12	UPWARD THRUST BLOCK DETAIL
B-13	WATER/SEWER SEPARATION REQUIREMENTS
B-14	REDUCED PRESSURE PRINCIPLE BACKFLOW PREVENTER
B-15-1	CORROSION PROTECTION WITH Mg ANODE
B-15-2	ANODE AND CONNECTION DETAILS



**SECTION C - SANITARY SEWER SYSTEM**

C-1-1	TYPE I ECCENTRIC MANHOLE
C-1-2	TYPE I ECCENTRIC MANHOLE
C-1-3	TYPE I ECCENTRIC DROP MANHOLE
C-2	MANHOLE CONSTRUCTION AND MATERIAL NOTES
C-3	MANHOLE FRAME AND COVER
C-4	FRAME AND COVER ADJUSTMENT IN PAVEMENT
C-5	SEWER LATERAL
C-6	LATERAL CONNECTION DETAIL

**SECTION D - STORM SEWER SYSTEM**

D-1-1	TYPE II ECCENTRIC MANHOLE
D-1-2	TYPE III ECCENTRIC MANHOLE
D-2-1	ANGLE MANHOLE-P.I. BASE
D-2-2	ANGLE MANHOLE-P.I. BASE
D-3-1	STRAIGHT THROUGH CAST IN PLACE MH
D-3-2	STRAIGHT THROUGH CAST IN PLACE MH
D-4	TYPE "A" CURB INLET CATCH BASIN
D-5	TYPE "B" CURB INLET CATCH BASIN
D-6	CURB INLET CATCH BASIN DETAIL AND NOTES
D-7	DROP INLET
D-8-1	INLET HOOD, FRAME AND GRATES
D-8-2	INLET HOOD, FRAME AND GRATES
D-9	CAST IN PLACE CONCRETE PIPE DETAIL
D-10	R.C.P. MITER BEND
D-11	LATERAL CONNECTION TO STORM MAIN
D-12	STORM DRAIN STANDARD CONNECTION
D-13-1	SIDEWALK UNDERDRAIN PIPE
D-13-2	SIDEWALK UNDERDRAIN PIPE

**SECTION E - BACKFILL, BEDDING, AND TRENCH REQUIREMENTS**

E-1-1	PIPE BEDDING AND TRENCH BACKFILL
E-2-1	TRENCH RESURFACING
E-1-2	PIPE BEDDING AND TRENCH BACKFILL NOTES
E-2-2	TRENCH RESURFACING
E-3-1	UNATTENDED EXCAVATION SAFETY
E-3-2	UNATTENDED EXCAVATION SAFETY
E-4	NARROW TRENCH RESTORATION

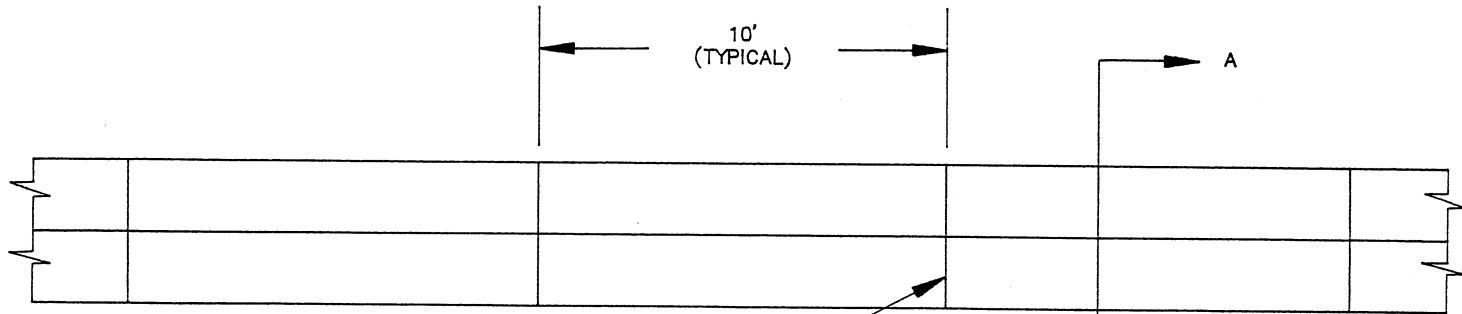

WEAKENED PLANE JOINT  
 1/8" X 2" DEEP WHEN CUT  
 AND 1/8" X 1/2" WHEN  
 FINISHED

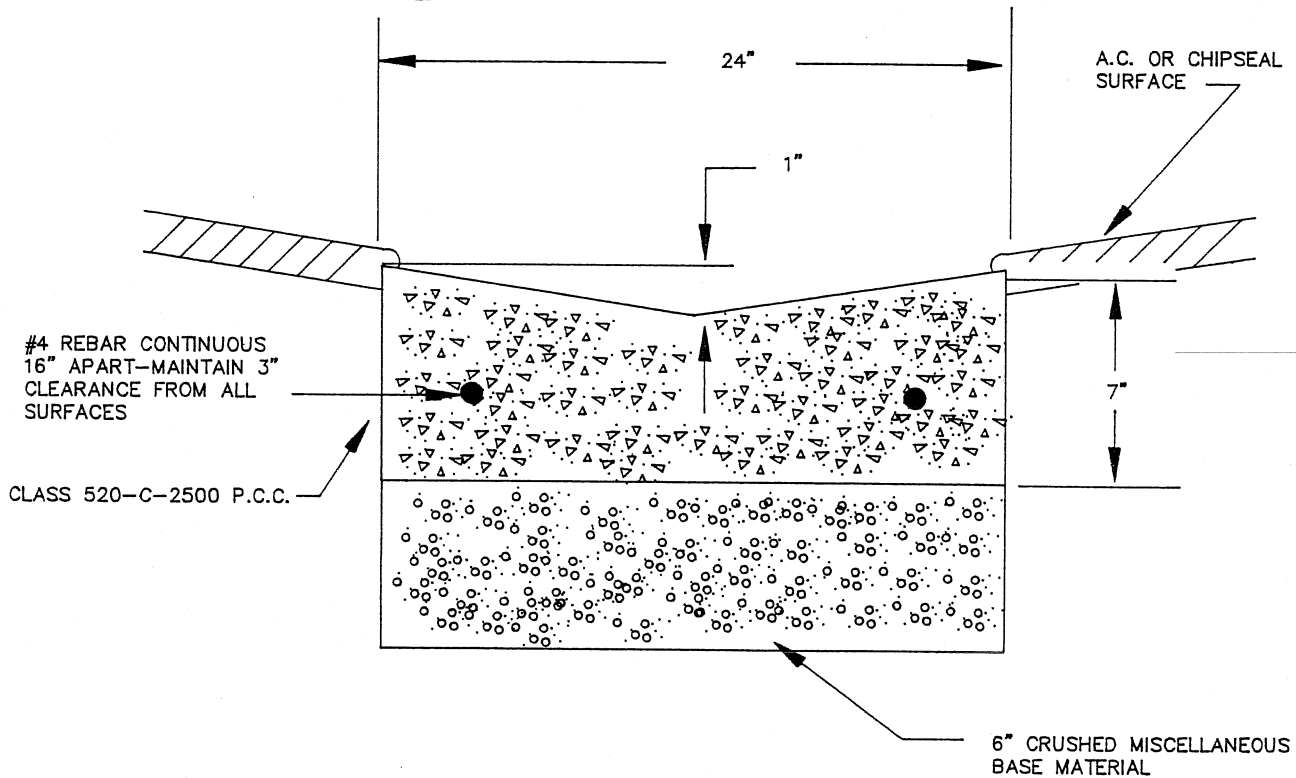

SECTION A - A

NOTES:

1. COMPACT SUBGRADE UNDER GUTTER TO MINIMUM 95% RELATIVE COMPACTION FOR A DEPTH OF 12", EXCEPT AS OTHERWISE SPECIFIED.
2. COMPACT CRUSHED MISCELLANEOUS BASE MATERIAL TO MINIMUM 95% RELATIVE COMPACTION.
3. ALL CONCRETE SURFACES TO HAVE A LIGHT BROOM FINISH AND BE TREATED WITH CURING COMPOUND.

" V " GUTTER

CITY OF HOLLISTER  
 STANDARD PLANS

APPROVED: *Max H. Bridges*

MAX H. BRIDGES R.C.E. 24152- EXP 12/31/93

DATE	APRIL 30, 1992
REVISED	
DETAIL	A-1

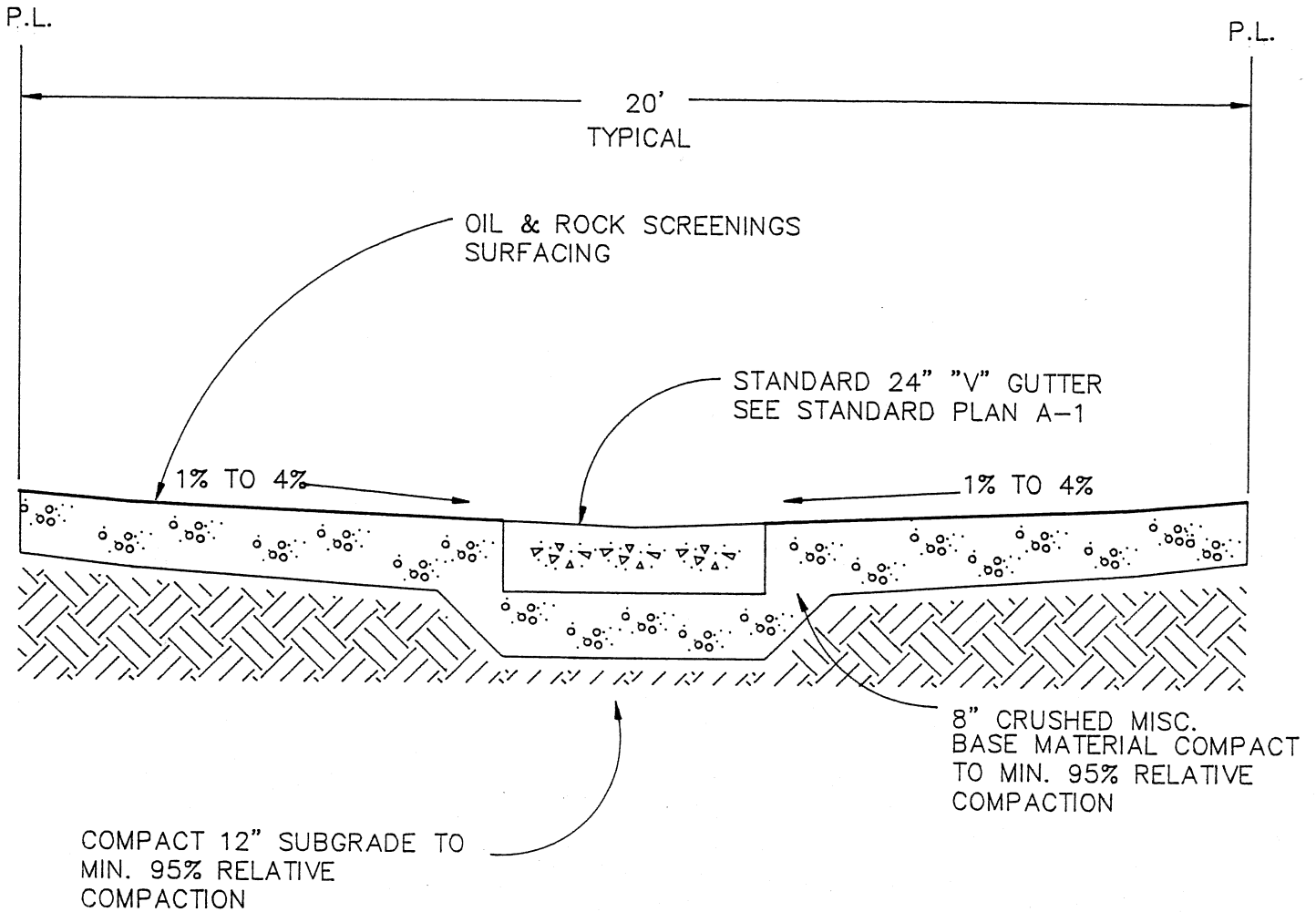

NOTES:

1. "V" GUTTER MAY BE DELETED WITH CITY ENGINEERS APPROVAL FOR MINOR ALLEY RECONSTRUCTION.
2. COMMERCIAL DRIVEWAYS ARE TO BE CONSTRUCTED AT EVERY ALLEY / STREET INTERSECTION. BACK OF DRIVEWAYS ARE TO BE NOTCHED TO ACCOMMODATE "V" GUTTER.

# ALLEY CONSTRUCTION REQUIREMENTS

CITY OF HOLLISTER  
STANDARD PLANS

APPROVED: \_\_\_\_\_

MAX H. BRIDGES R.C.E. 24152 - EXP. 12/31/93

DATE	APRIL 30, 1992
REVISED	
DETAIL	A-2

3" DEEP DOWEL HOLES  
TO BE PROVIDED AT  
4' O.C.

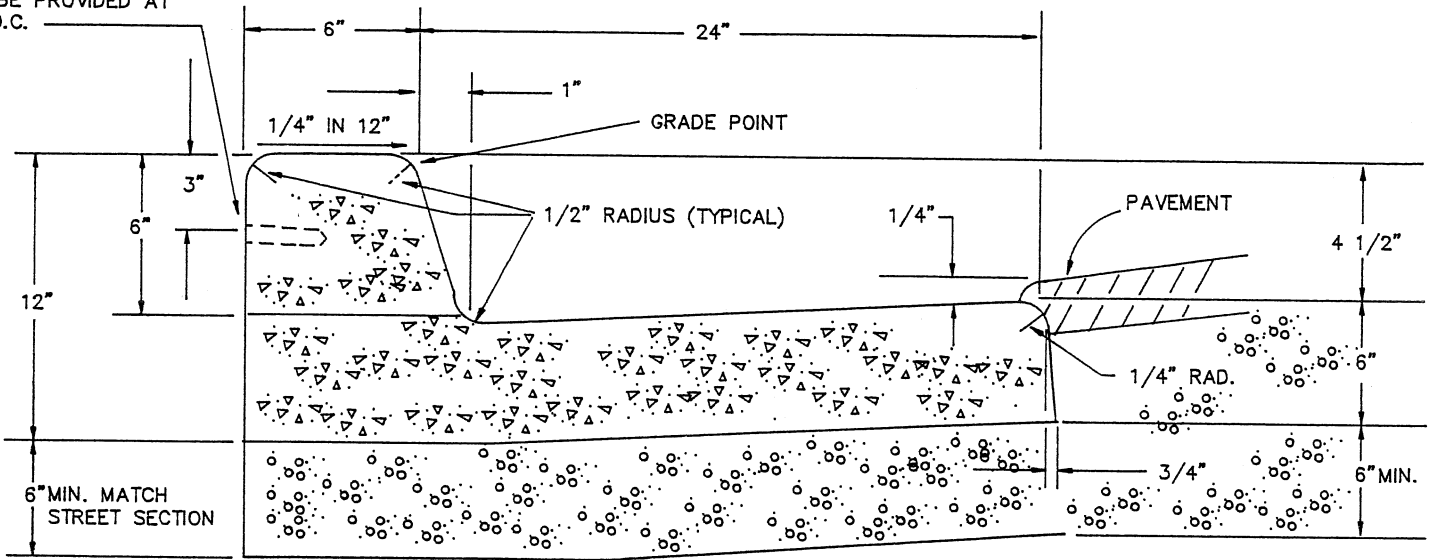

TYPE I CURB (0.05691 C.Y./L.F.)

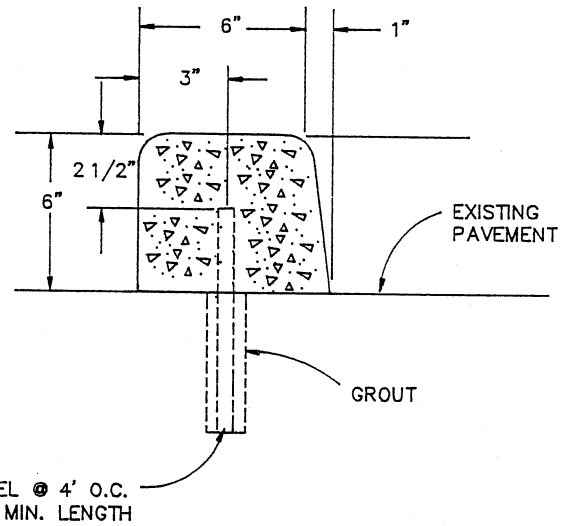
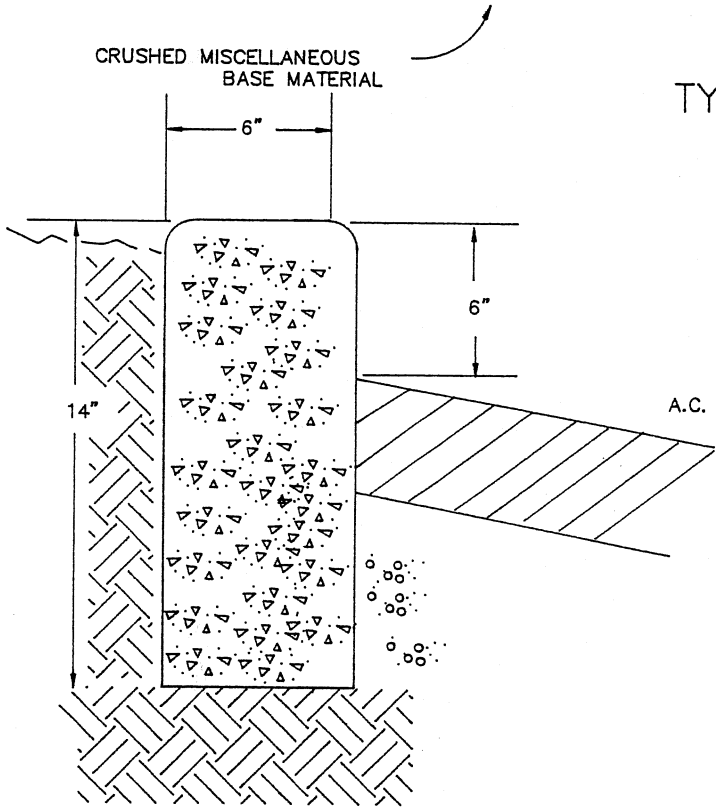

TYPE II CURB (0.02443 C.Y./L.F.) TYPE III CURB (0.01003 C.Y./L.F.)

NOTE:

1. COMPACT SUBGRADE MATERIAL UNDER ALL CURB & GUTTER TO MINIMUM 95% RELATIVE COMPACTION FOR A DEPTH OF 12", EXCEPT AS OTHERWISE SPECIFIED.
2. COMPACT CRUSHED MISCELLANEOUS BASE MATERIAL TO MINIMUM 95% RELATIVE COMPACTION.
3. ALL CURB AND GUTTER TO BE CLASS 520-C-2500 P.C.C. EXTRUDED CURB & GUTTER MAY BE CLASS 520-D-2500 P.C.C.
4. EXPANSION JOINTS SHALL BE 1/4" X FULL P.C.C. DEPTH, PLACED AT EACH SIDE OF DRIVEWAYS AND CATCH BASINS, AT BCR & BCR, AND AT A MAXIMUM DISTANCE OF 60.
5. WEAKENED PLANE JOINTS SHALL BE 1/8" X 2" DEEP WHEN CUT AND 1/8" X 1/2" DEEP WHEN FINISHED, AND PLACED EVERY 10 FEET.
6. ALL CONCRETE SURFACES SHALL HAVE A LIGHT BROOM FINISH PARALLEL WITH THE STREET AND BE TREATED WITH CURING COMPOUND.

CURBS AND GUTTER

CITY OF HOLLISTER  
STANDARD PLANS

APPROVED:

*Max H. Bridges*

MAX H. BRIDGES P.E. 24152 EXP. 12/31/03

DATE	APRIL 30, 1992
REVISED	
DETAIL	A-3 SHEET 1 OF 1

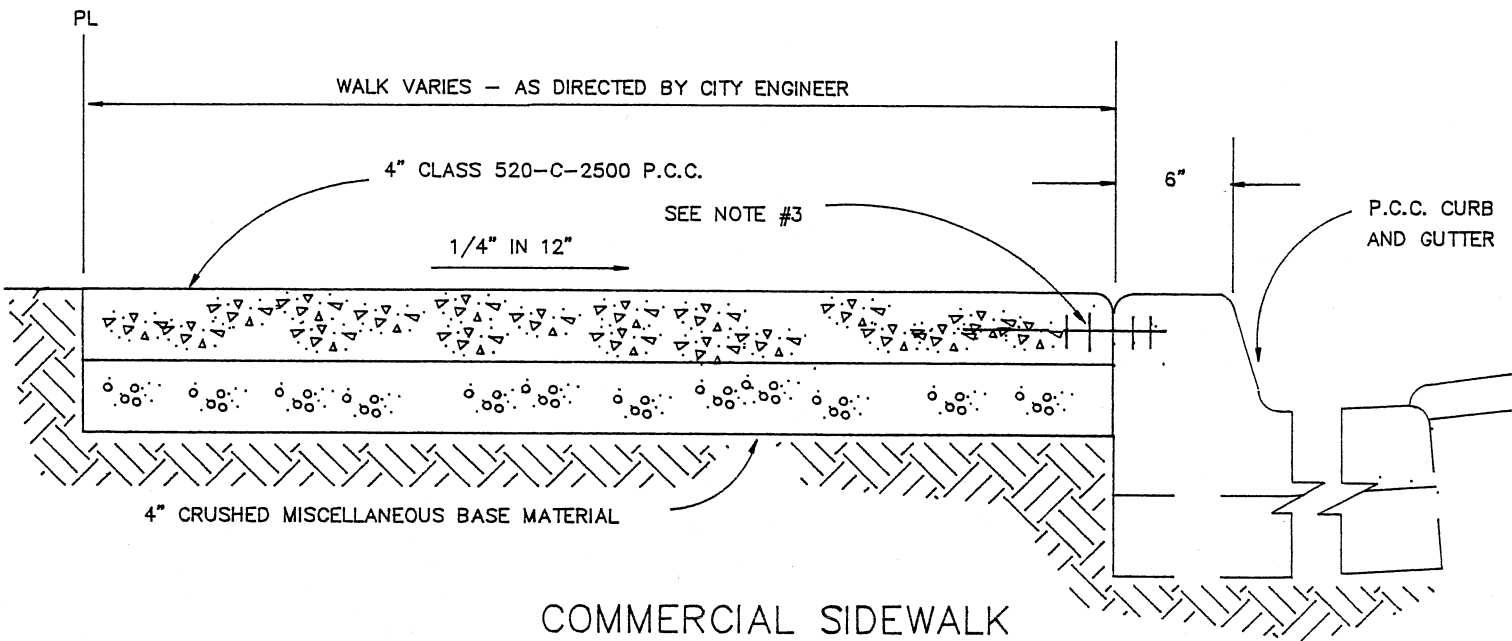

COMMERCIAL SIDEWALK

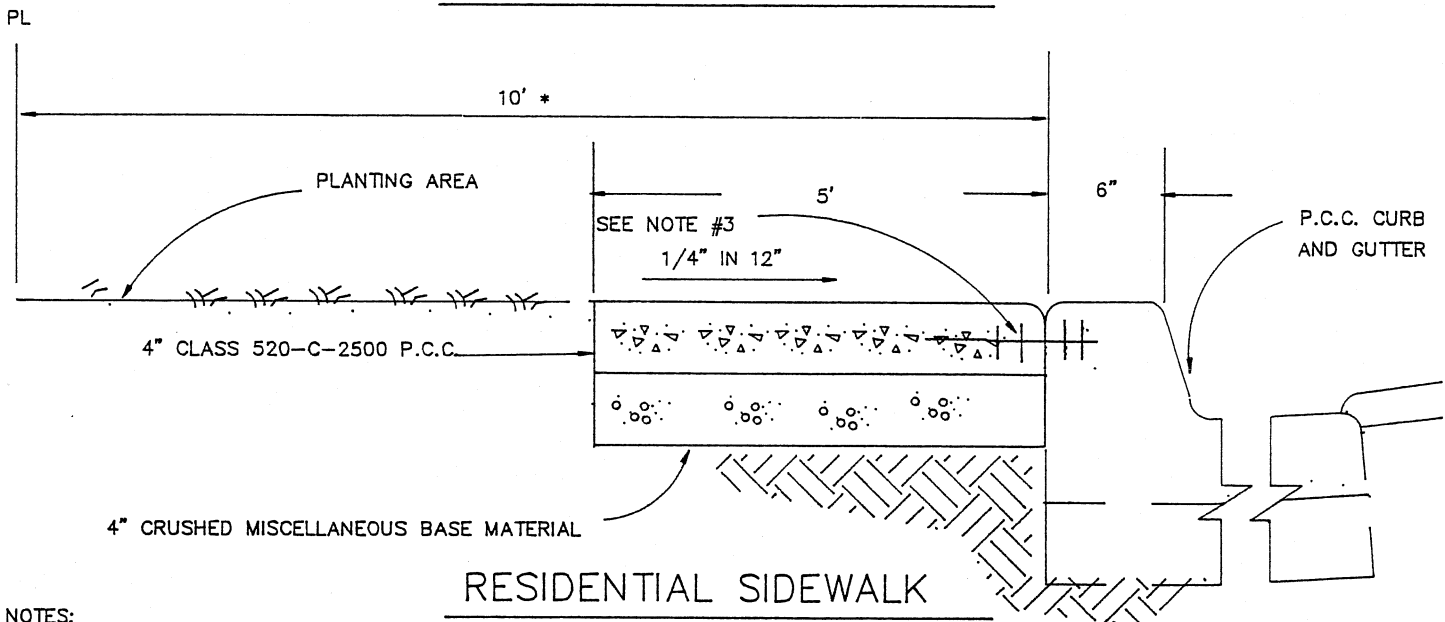

RESIDENTIAL SIDEWALK

NOTES:

1. COMPACT SUBGRADE MATERIAL UNDER SIDEWALK TO MINIMUM 90% RELATIVE COMPACTION FOR A MINIMUM DEPTH OF 6".
  2. COMPACT CRUSHED MISCELLANEOUS BASE MATERIAL UNDER SIDEWALK TO MINIMUM 95% RELATIVE COMPACTION.
  3. PLACE MINIMUM 16" LONG #4 DOWEL AT 4' O.C. UNLESS CURB AND SIDEWALK ARE POURED MONOLITHICALLY. DRILL DOWEL HOLES INTO CURB TO 3" MINIMUM DEPTH.
  4. EXPANSION JOINTS SHALL BE 1/4" X FULL P.C.C. DEPTH, PLACED AT EACH SIDE OF DRIVEWAYS AND CATCH BASINS, AT BCR & ECR, AND AT A MAXIMUM DISTANCE OF 60 FEET.
  5. WEAKENED PLANE JOINTS SHALL BE 1/8" X 2" DEEP WHEN CUT AND 1/8" X 1/2" DEEP WHEN FINISHED AND PLACED EVERY 10 FEET. SIDEWALKS WIDER THAN 5 FEET SHALL HAVE A LONGITUDINAL WEAKENED PLANE JOINT AT CENTERLINE.
  6. SCORE MARKS SHALL BE MINIMUM 1/8" DEEP AND PLACED EVERY 5 FEET.
  7. ALL CONCRETE SURFACES SHALL HAVE A LIGHT BROOM FINISH PERPENDICULAR OR RADIAL TO THE STREET AND BE TREATED WITH CURING COMPOUND.
  8. ADEQUATE PRESATURATION OF SUBGRADE UNDER SIDEWALK AREAS SHALL BE ACHIEVED A MINIMUM OF 48 HOURS PRIOR POURING AND MAINTAINED UNTIL TIME OF POUR.
- \* 5 FEET FROM FACE OF CURB TO PROPERTY LINE ON CUL-DE-SAC REQUIRES 6 FOOT WIDE SIDEWALK EASEMENT.

SIDEWALK

CITY OF HOLLISTER  
STANDARD PLANS

APPROVED: *Max A. ...*

DATE	APRIL 30, 1992
REVISED	
DETAIL	△ - △ SHEET 1 OF 1



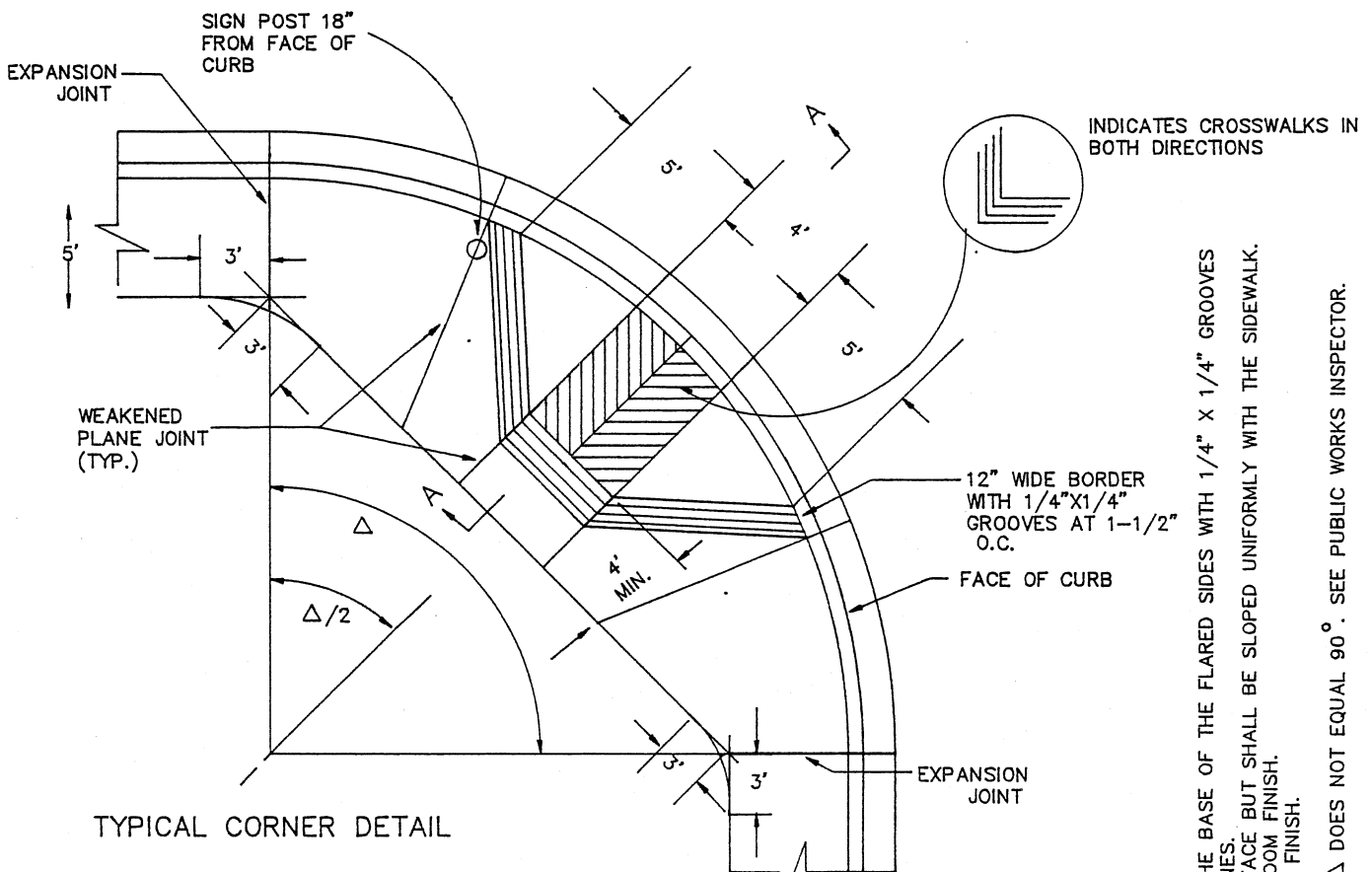

TYPICAL CORNER DETAIL

PLAN VIEW

SEE STANDARD PLAN A-5-2 FOR SECTION A-A

CORNER TRANSITION DETAIL

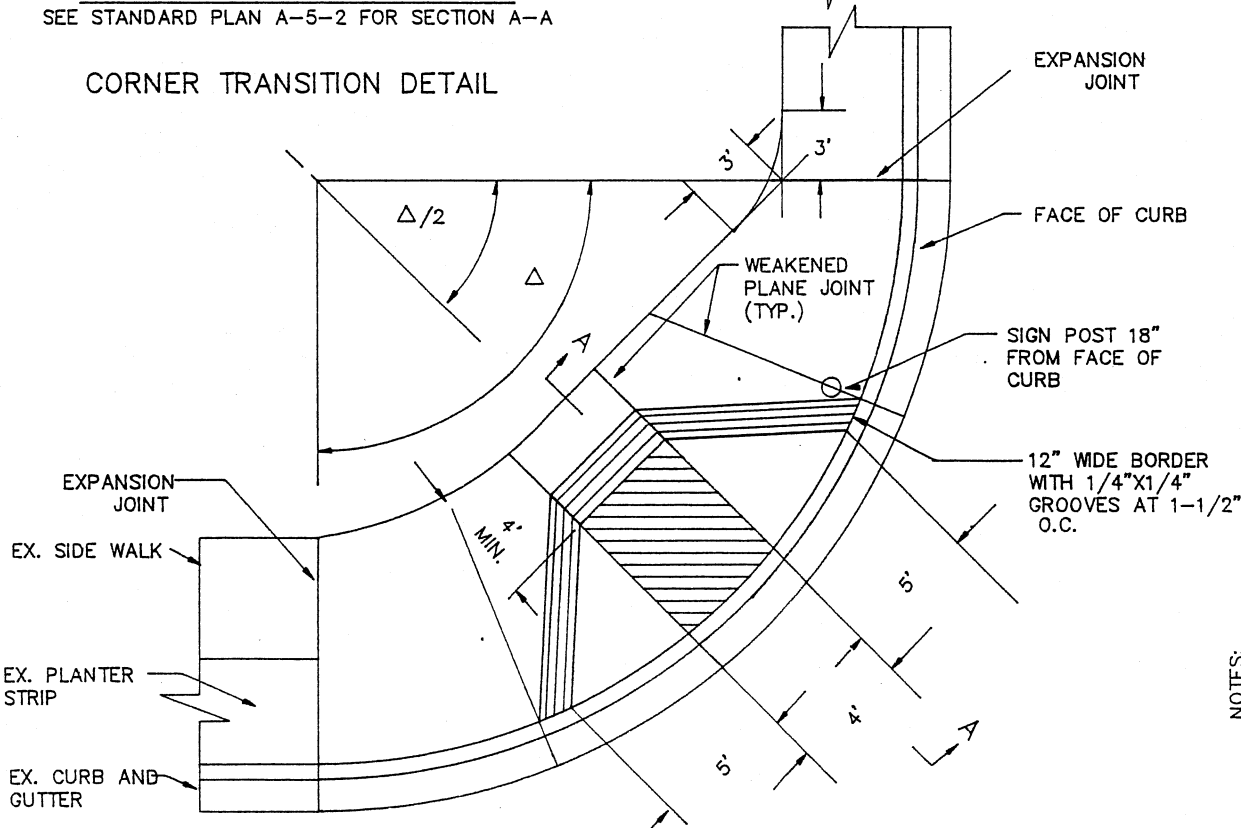

INDICATES CROSSWALKS IN BOTH DIRECTIONS

- NOTES:
1. ALL RAMPs SHALL BE GROOVED FROM THE CENTER LINE TO THE BASE OF THE FLARED SIDES WITH 1/4" X 1/4" GROOVES AT 1 1/2" O.C. RUNNING PARALLEL TO CROSSWALK CENTERLINES.
  2. THE 12" BORDER SHALL NOT BE A PART OF THE RAMP SURFACE BUT SHALL BE SLOPED UNIFORMLY WITH THE SIDEWALK.
  3. THE FLARED SIDES OF ALL RAMPs SHALL HAVE A HEAVY BROOM FINISH.
  4. THE SURFACE OF ALL RAMPs SHALL HAVE A MEDIUM BROOM FINISH.
  5. THE 12" BORDER SHALL HAVE A MEDIUM BROOM FINISH.
  6. SIGN POST LOCATION ADJUSTMENT MAY BE REQUIRED WHEN Δ DOES NOT EQUAL 90°. SEE PUBLIC WORKS INSPECTOR.

# CONCRETE SIDEWALK RAMP & CORNER DETAIL

CITY OF HOLLISTER  
STANDARD PLANS

APPROVED: *[Signature]*

MAY H. BRIDGES, P.E. 24152 EXP. 12/31/03

DATE	APRIL 30, 1992
REVISED	

DETAIL	A-5-1
	SHEET 1 OF 2

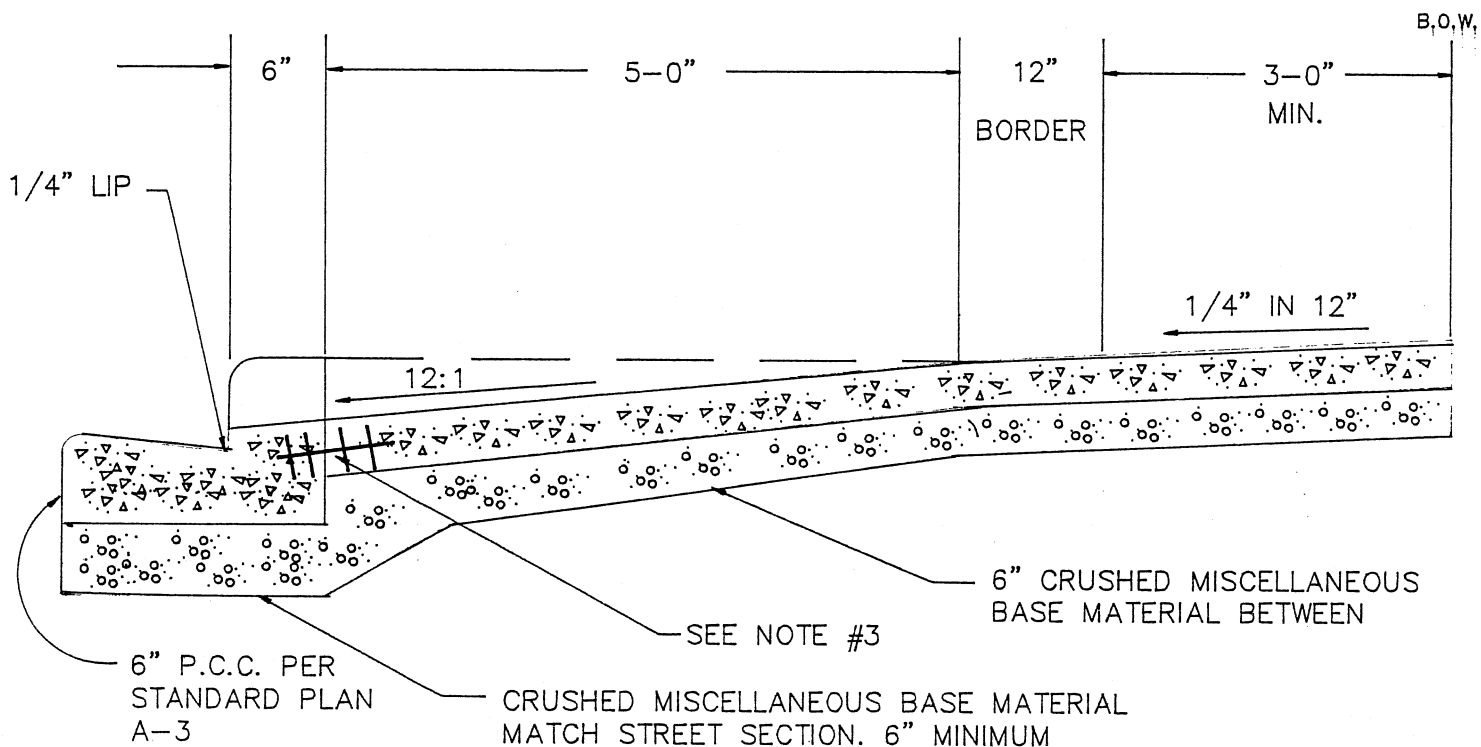

## SECTION A-A

SEE STANDARD PLAN A-5-1 FOR PLAN VIEW

### NOTES:

1. COMPACT SUBGRADE MATERIAL UNDER HANDICAP RAMP AND SIDEWALK TO MINIMUM 90% RELATIVE COMPACT FOR A DEPTH OF 6".
2. COMPACT CRUSHED MISCELLANEOUS BASE MATERIAL UNDER HANDICAP RAMP AND SIDEWALK TO MINIMUM 95% RELATIVE COMPACTION.
3. PLACE MINIMUM 16" LONG DOWELL AT 4' O.C. UNLESS CURB AND SIDEWALK ARE POURED MONOLITHICALLY. DRILL DOWEL HOLES INTO CURB A MINIMUM DEPTH OF 3 INCHES.
4. EXPANSION JOINTS SHALL BE 3/8" X FULL P.C.C. DEPTH, PLACED ON EACH SIDE OF CORNER RADIUS.
5. WEAKENED PLANE JOINTS SHALL BE 1/8" X 2" DEEP WHEN CUT AND 1/8" X 1/2" DEEP WHEN FINISHED
6. CUT WEAKENED PLANE JOINT INTO BACK OF CURB ON MONOLITHIC POURS.
7. ALL CONCRETE SURFACES TO HAVE A LIGHT BROOM FINISH ( UNLESS OTHERWISE SHOWN ) AND TO BE TREATED WITH CURING COMPOUND.

## SIDEWALK RAMP & CORNER DETAILS

CITY OF HOLLISTER

STANDARD PLANS

APPROVED: *Max H. Bridges*

MAX H. BRIDGES R.C.E. 24152- EXP. 12/31/93

DATE

APRIL 30, 1992

REVISED

DETAIL

A-5-2

SHEET 2 OF 2

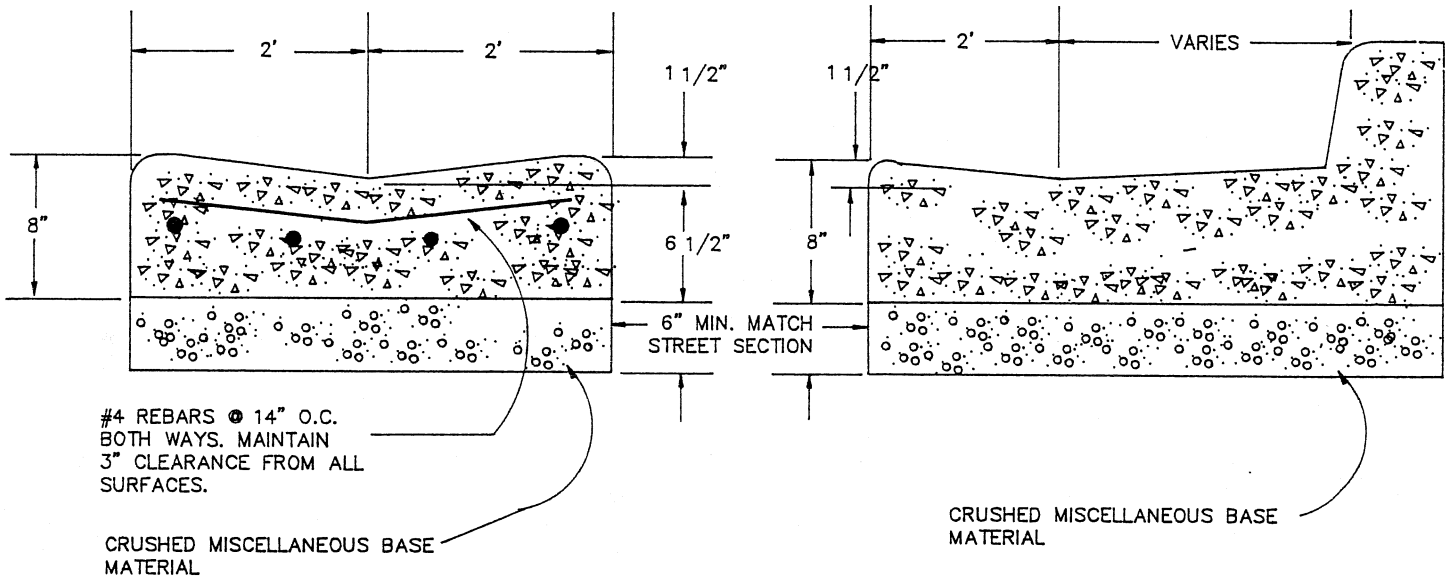
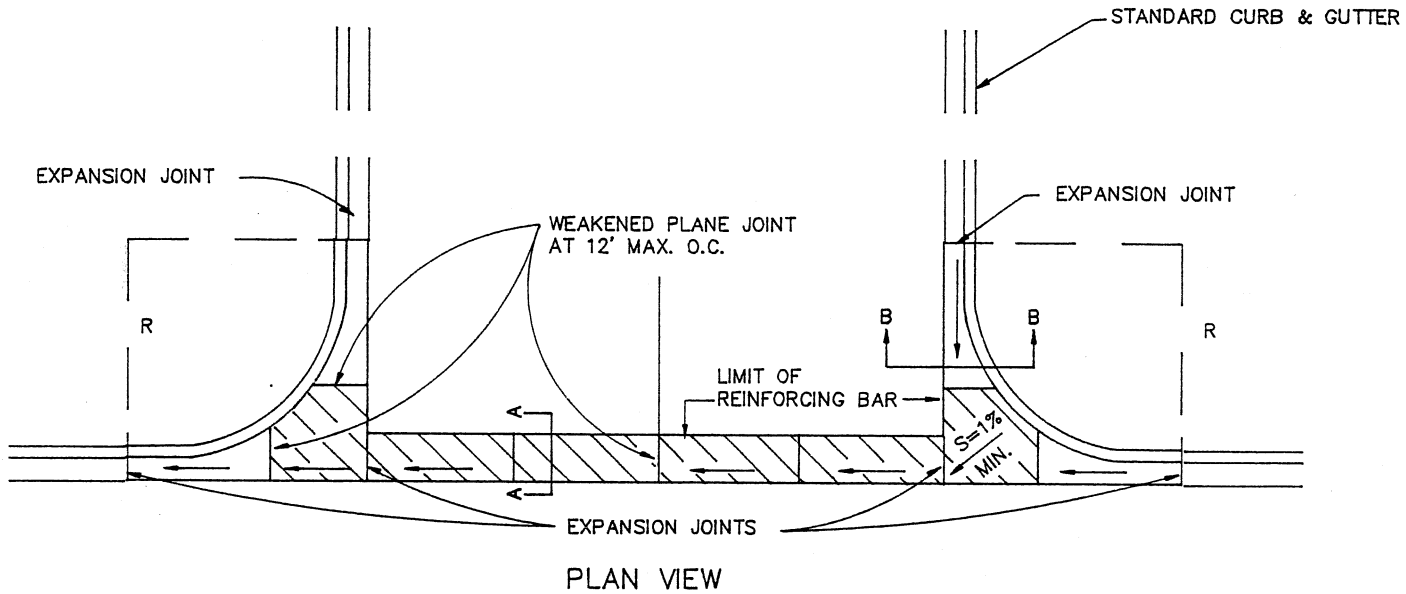

- NOTES:
1. COMPACT SUBGRADE UNDER ALL CURB AND GUTTER TO MINIMUM 95% RELATIVE COMPACTION FOR A DEPTH OF 12" EXCEPT AS OTHERWISE SPECIFIED.
  2. COMPACT CRUSHED MISCELLANEOUS BASE MATERIAL TO MINIMUM 95% RELATIVE COMPACTION.
  3. ALL CURB AND GUTTER SHALL BE CLASS 520-C-2500 P.C.C.
  4. EXPANSION JOINTS SHALL BE 1/4" X FULL P.C.C. DEPTH.
  5. WEAKENED PLANE JOINTS SHALL BE 1/8" X 2" DEEP WHEN CUT AND 1/8" X 1/2" DEEP WHEN FINISHED.
  6. TERMINATE REINFORCING BARS ON EACH SIDE OF EXPANSION JOINT.
  7. ALL CONCRETE SURFACES SHALL HAVE A LIGHT BROOM FINISH AND BE TREATED WITH CURING COMPOUND.
  8. INSTALL 3" DEEP DOWEL HOLES AT 4' O.C. IN BACK OF CURB.

## CROSS GUTTER

CITY OF HOLLISTER

STANDARD PLANS

APPROVED: *Max H. Bridges*

MAX H. BRIDGES P.C.E. 24152- EXP. 12/31/93

DATE	APRIL 30, 1992
REVISED	
DETAIL	A-6

SHEET 1 OF 1

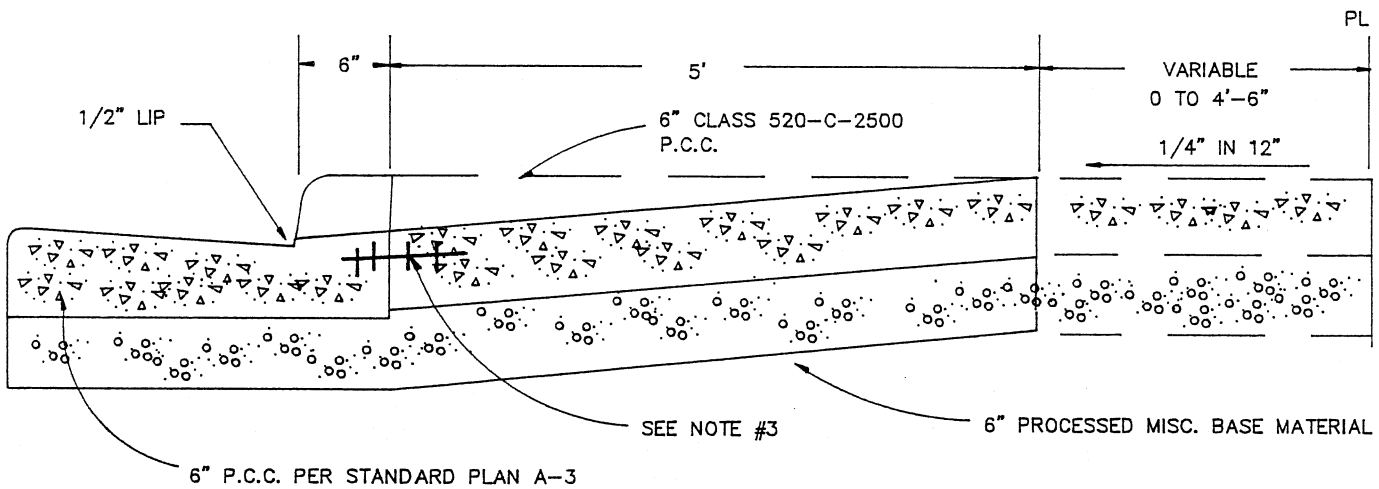
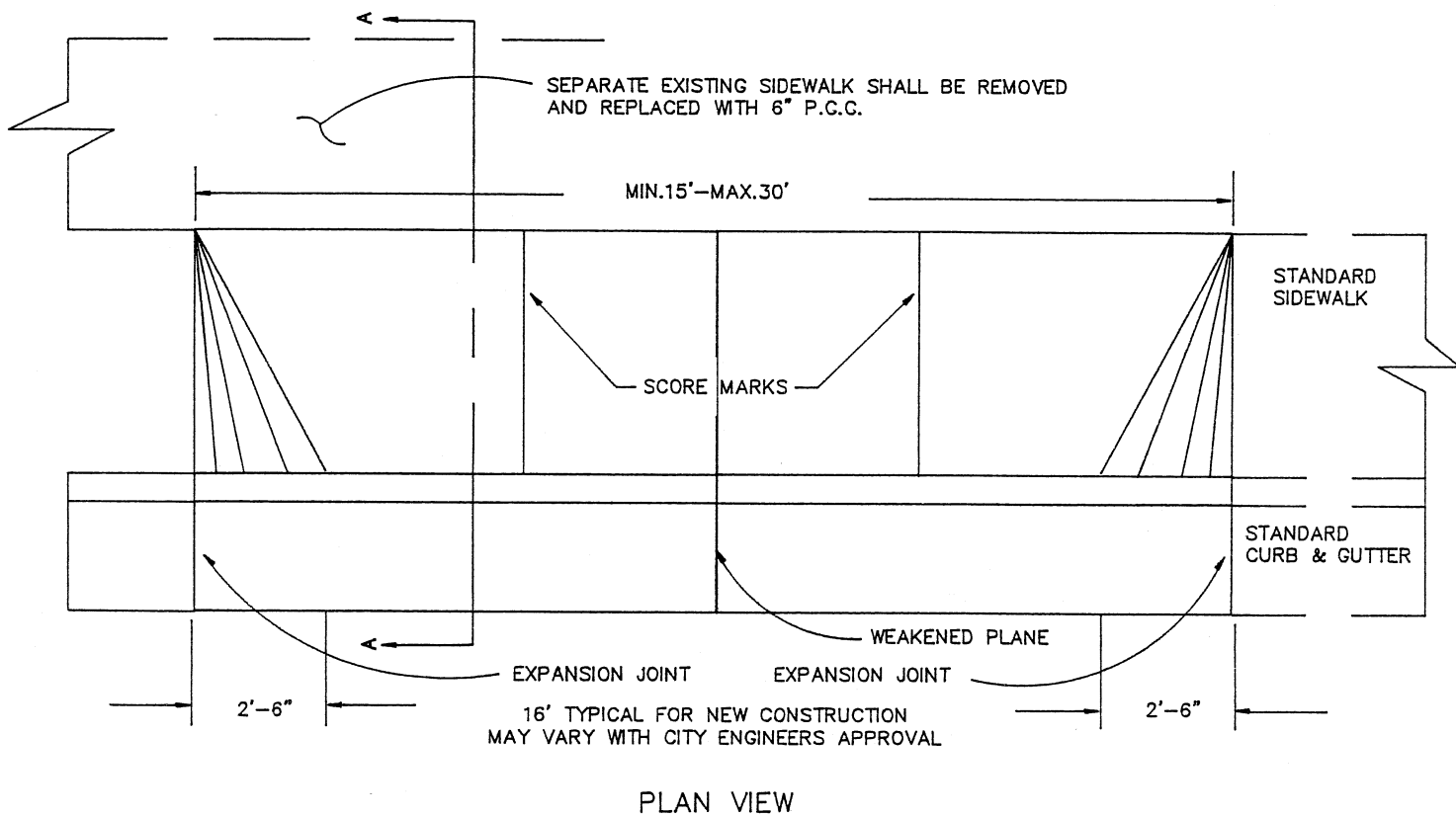

- NOTES:
1. COMPACT SUBGRADE MATERIAL UNDER DRIVEWAY TO MINIMUM 90% RELATIVE COMPACTION FOR A DEPTH OF 6", EXCEPT AS OTHERWISE SPECIFIED.
  2. COMPACT CRUSHED MISCELLANEOUS BASE MATERIAL TO MINIMUM 95% RELATIVE COMPACTION.
  3. PLACE MINIMUM 16" LONG #4 DOWEL AT 4' O.C. UNLESS CURB AND DRIVEWAY ARE POURED MONOLITHICALLY. DRILL HOLES INTO CURB TO MINIMUM 3" DEPTH.
  4. EXPANSION JOINTS SHALL BE 1/4" X FULL P.C.C. DEPTH, PLACE AT EACH SIDE OF DRIVEWAYS.
  5. WEAKENED PLANE JOINTS SHALL BE 1/8" X 2" DEEP WHEN CUT AND 1/8" X 1/2" WHEN FINISHED, PLACE AT CENTERLINE OF DRIVEWAY.
  6. PLACE WEAKENED PLANE JOINT AT BACK OF CURB LINE IF CURB, GUTTER, AND DRIVEWAY ARE POURED MONOLITHICALLY.
  7. BACK OF DRIVEWAY APPROACH MAY BE SET 3" LOWER THAN BACK OF WALK TO FACILITATE LOT DRAINAGE.
  8. ALL CONCRETE SURFACES SHALL HAVE A LIGHT BROOM FINISH AND BE TREATED WITH CURING COMPOUND.

## RESIDENTIAL DRIVEWAY

CITY OF HOLLISTER

STANDARD PLANS

APPROVED: Max H. Bridges  
MAX H. BRIDGES R.C.E. 24152- EXP. 12/31/93

DATE	APRIL 30, 1992
REVISED	
DETAIL	A-7
SHEET 1 OF 1	

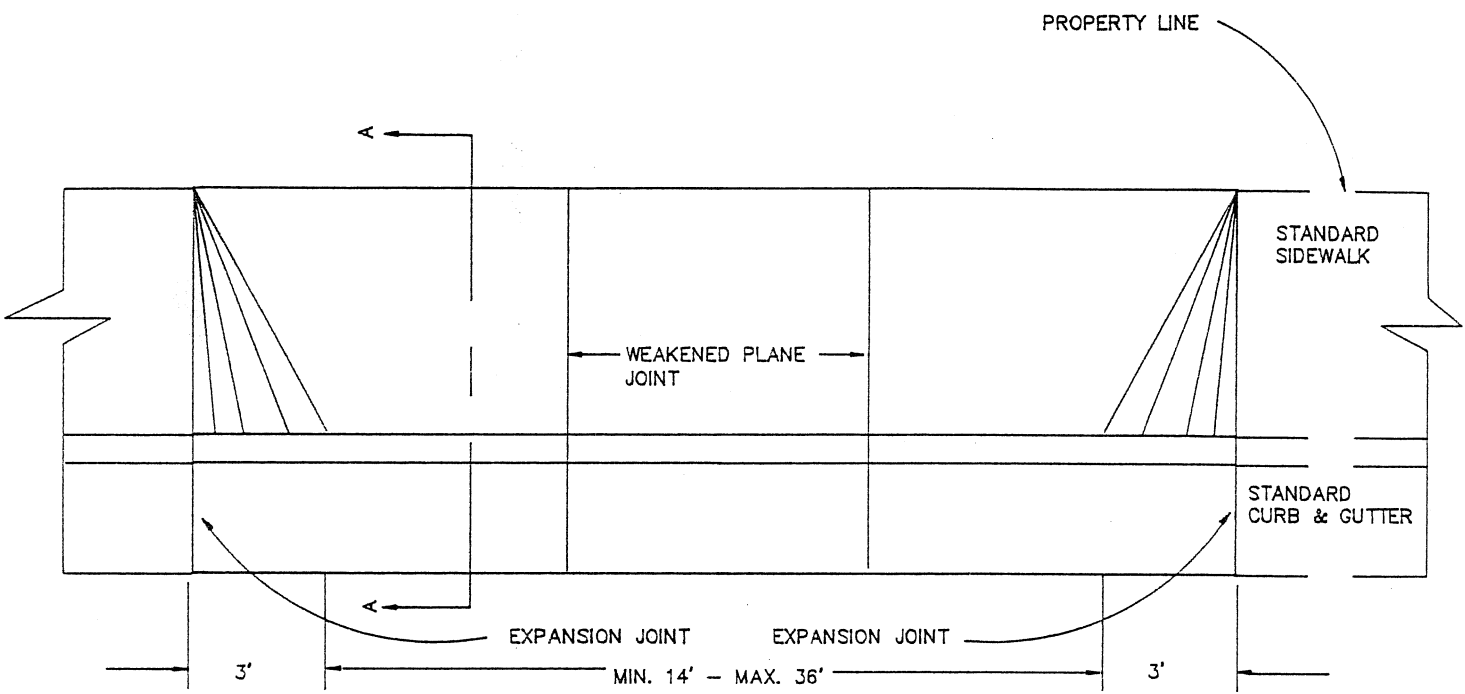

STANDARD DRIVEWAY PLAN VIEW

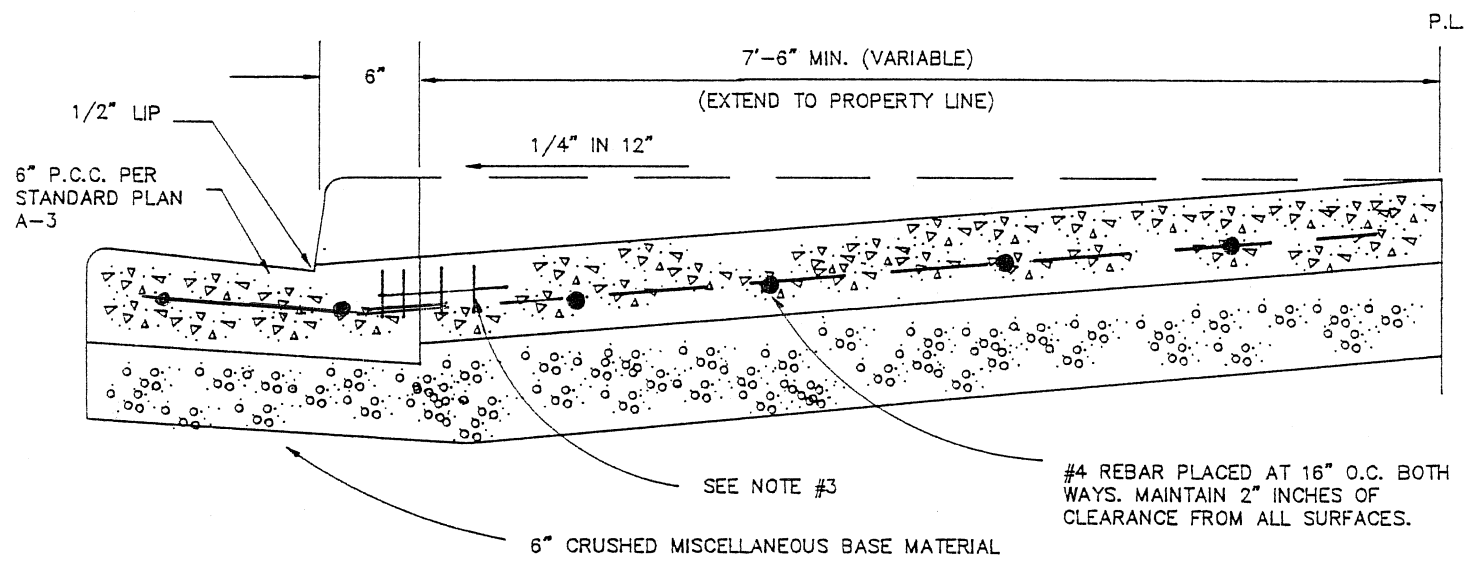

SECTION A-A

NOTES:

1. COMPACT SUBGRADE MATERIAL UNDER ALL CURB, GUTTER AND DRIVEWAYS TO MINIMUM 95% RELATIVE COMPACTION FOR A DEPTH OF 12", EXCEPT AS OTHERWISE SPECIFIED.
2. COMPACT CRUSHED MISCELLANEOUS BASE MATERIAL TO MINIMUM 95% RELATIVE COMPACTION.
3. PLACE MINIMUM 16" LONG #4 DOWELS AT 4' O.C UNLESS CURB, GUTTER AND DRIVEWAY ARE POURED MONOLITHICALLY.
4. EXPANSION JOINTS SHALL BE 1/4" X FULL P.C.C. DEPTH, PLACED AT EACH SIDE OF OF DRIVEWAYS.
5. WEAKENED PLANE JOINTS SHALL BE 1/8" X 2" DEEP WHEN CUT AND 1/8" X 1/2" DEEP WHEN FINISHED, PLACE AT APPROXIMATELY 10' INTERVALS.
6. PLACE WEAKENED PLANE JOINT AT BACK OF CURB IF CURB, GUTTER, AND DRIVEWAY ARE POURED MONOLITHICALLY.
7. ALL CONCRETE SURFACES TO HAVE A LIGHT BROOM FINISH, EXCEPT AS OTHERWISE SPECIFIED, AND BE TREATED WITH CURING COMPOUND.

COMMERCIAL DRIVEWAYS

CITY OF HOLLISTER

STANDARD PLANS

APPROVED: *[Signature]*

DATE	APRIL 30, 1992
REVISED	
DETAIL	Δ - 8 - 1

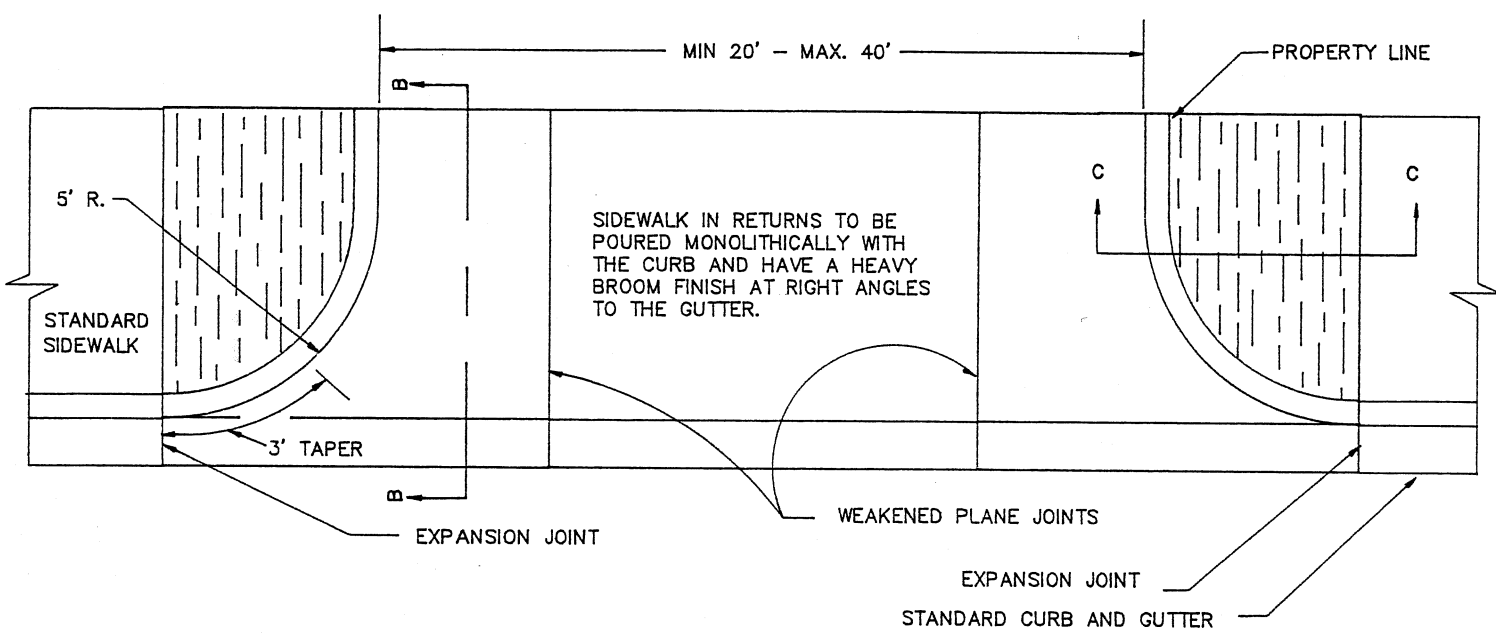

SMALL RADIUS DRIVEWAY PLAN VIEW

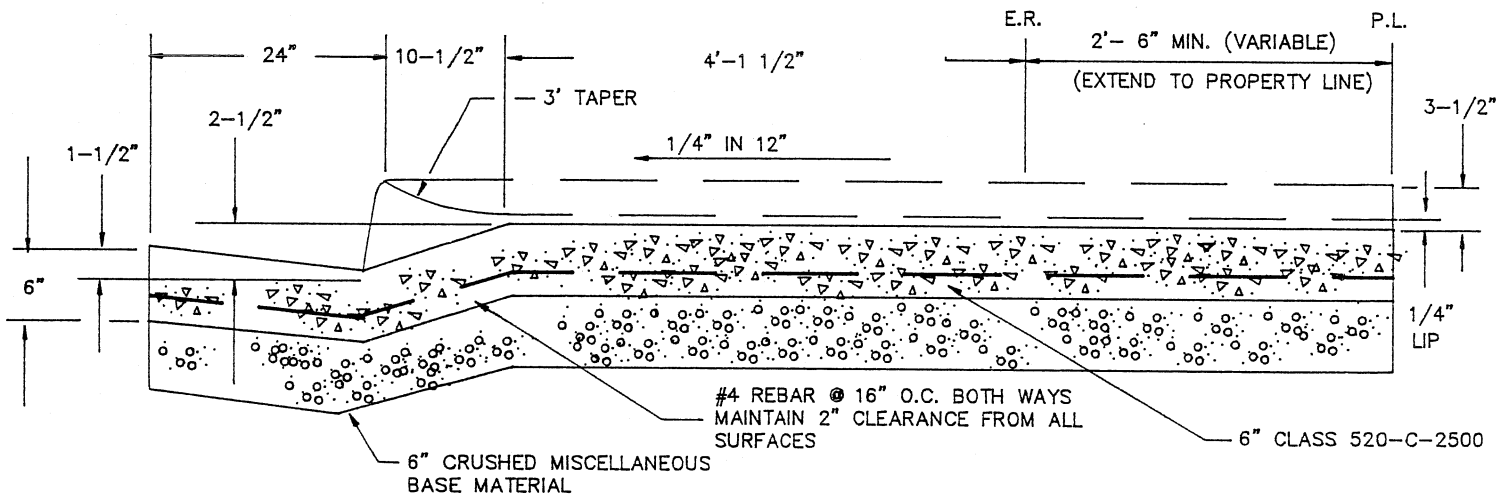

SECTION B-B

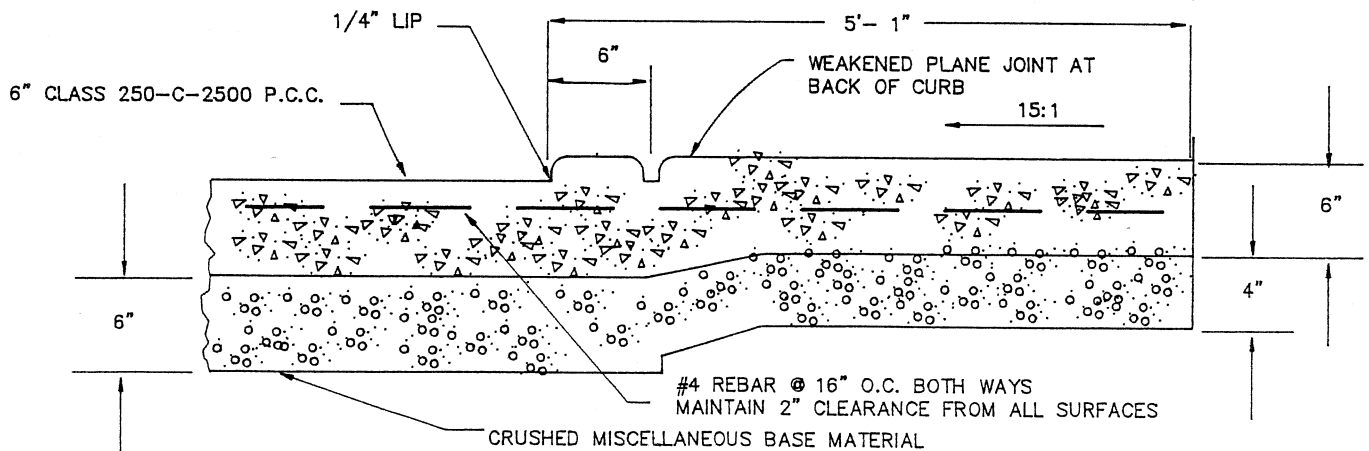

SECTION C-C

COMMERCIAL DRIVEWAYS

CITY OF HOLLISTER

STANDARD PLANS

APPROVED:

*Max H. Bridges*

MAY H. BRIDGES, P.C.E. 24152 - EXP. 12/31/03

DATE

APRIL 30, 1992

REVISED

DETAIL

A-8-2

SHEET 2 OF 2

SS-1H EMULSIFIED ASPHALT  
ALL SURFACES TO BE PAVED ON  
OR AGAINST

NEW CURB AND GUTTER

EXISTING STREET  
SECTION

36" OR LESS

2-1/2" ASPHALT CONCRETE

1/4"

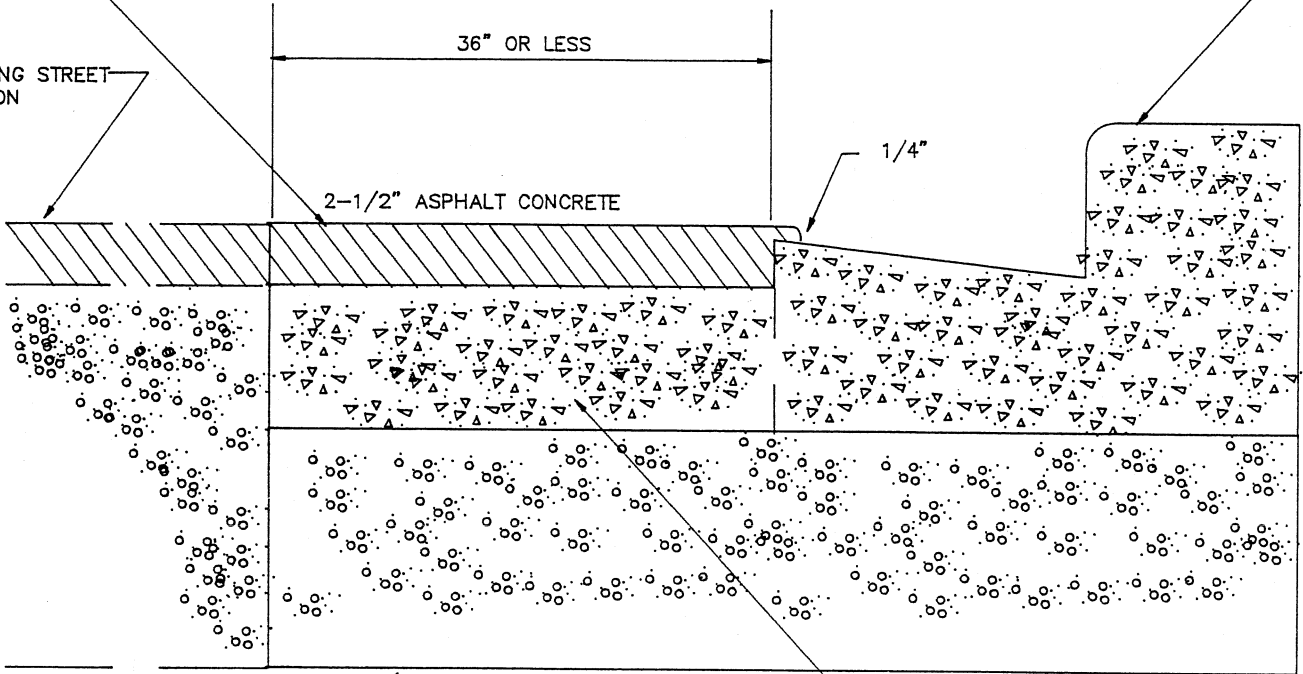

6" MIN. CRUSHED MISCELLANEOUS BASE  
MATERIAL MATCH STREET SECTION

APPROXIMATELY 4" CLASS 520-C-2500  
P.C.C. TO BE POURED MONOLITHICALLY  
WITH CURB AND GUTTER

NOTES:

1. USE WHERE EXISTING ASPHALT CONCRETE IS CUT TO INSTALL NEW CURB AND THE NEW CURB AND GUTTER FALL 3' OR LESS FROM THE EDGE OF EXISTING ASPHALT CONCRETE.
2. COMPACT SUBGRADE MATERIAL TO MINIMUM 95% COMPACTION FOR A DEPTH OF 12", EXCEPT AS OTHERWISE SPECIFIED.
3. COMPACT CRUSHED MISCELLANEOUS BASE MATERIAL TO A MINIMUM OF 95% RELATIVE COMPACTION

PAVEMENT TO CURB TRANSITION

CITY OF HOLLISTER

STANDARD PLANS

APPROVED:

MAX H. BRIDGES R.C.E. 24152- EXP. 12/31/93

DATE

APRIL 30, 1992

REVISED

DETAIL

A-9

SHEET 1 OF 1

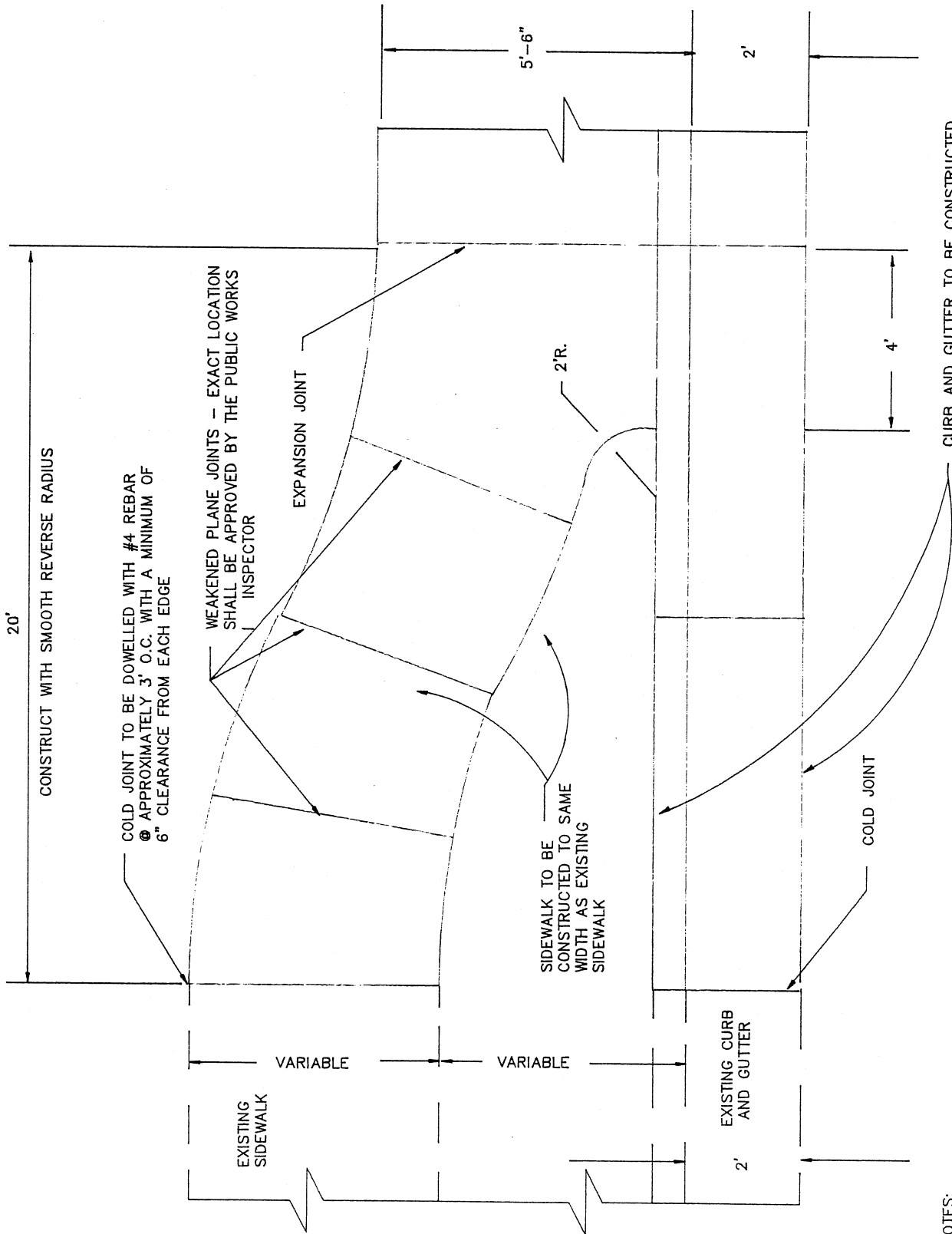

NOTES: 1. SEE STANDARD PLAN A-4 FOR SIDEWALK CONSTRUCTION NOTES. CURB AND GUTTER TO BE CONSTRUCTED

# SIDEWALK TRANSITION DETAIL

## CITY OF HOLLISTER

### STANDARD PLANS.

APPROVED: *Max H. Bridges*

MAX H. BRIDGES R.C.E. 24152- EXP. 12/31/93

DATE	APRIL 30, 1992
REVISED	
DETAIL	A-10 SHEET 1 OF



NOTES:

1. STREET SIGN LOCATION SHOWN ON STANDARD PLAN A-5-1.
2. SEE STANDARD PLAN A-14-1 AND A-14-2 FOR STOP SIGN AND PAVEMENT MARKING REQUIREMENTS.
3. STREET NAME SIGN LETTERS TO BE 4" BLOCK, ALL CAPITALS, SERIES B OR C WHITE LETTERS ON A GREEN BACKGROUND.

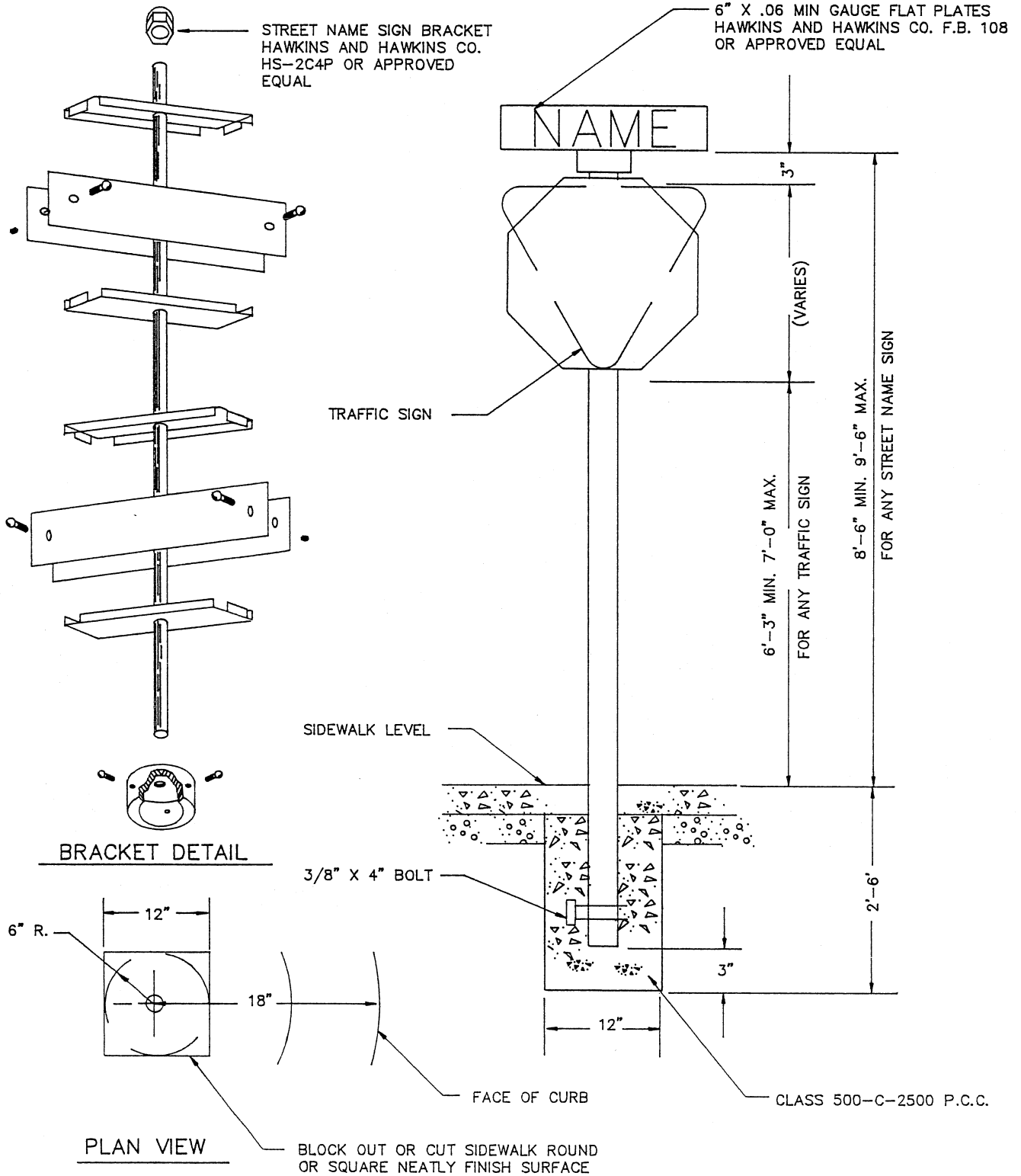

# STREET NAME & TRAFFIC SIGNS

## CITY OF HOLLISTER

### STANDARD PLANS

APPROVED:

*Max H. Bridges*

MAX H. BRIDGES R.C.E. 24152- EXP. 12/31/93

DATE	APRIL 30, 1992
REVISED	

DETAIL	A-11
--------	------

CONCRETE CURB GUTTER AND SIDEWALK

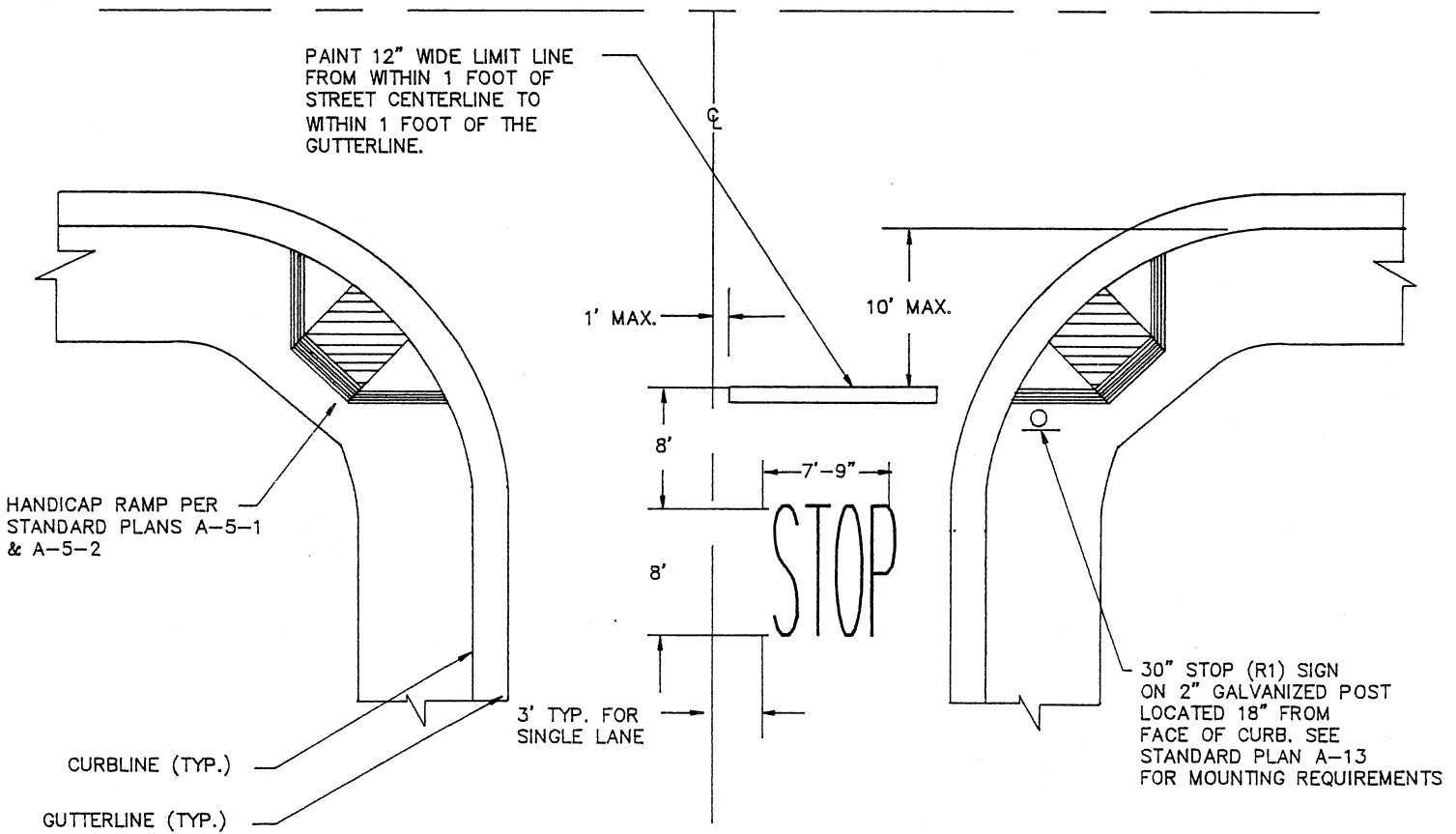

NOTES:

1. UNLESS OTHERWISE SPECIFIED, LIMIT LINES AND STOP LEGENDS SHALL BE PAINTED AT ALL STOP SIGN LOCATIONS.
2. LIMIT LINES SHALL BE PLACED AT HANDICAP RAMP BORDERS OR 10' FROM FACE OF CURB, WHICHEVER IS LESS.
3. UNDER NO CIRCUMSTANCE SHALL A LIMIT LINE BE USED IN CONJUNCTION WITH A CROSSWALK.
4. SEE STANDARD PLAN A-12-2 FOR LIMIT LINE PLACEMENT WHERE HANDICAP RAMPS ARE NOT PRESENT.

STOP SIGN AND PAVEMENT MARKINGS

CITY OF HOLLISTER

STANDARD PLANS

APPROVED: *Max H. Bridges*

MAX H. BRIDGES R.C.E. 24152 - EXP. 12/31/93

DATE	APRIL 30, 1992
REVISED	
DETAIL	A-12-1 SHEET 1 OF 2

SEE STANDARD PLAN A-12-1 FOR LIMIT LINE PLACEMENT WHERE HANDICAP RAMPS ARE CONSTRUCTED.

CURB/GUTTER WITH NO SIDEWALK

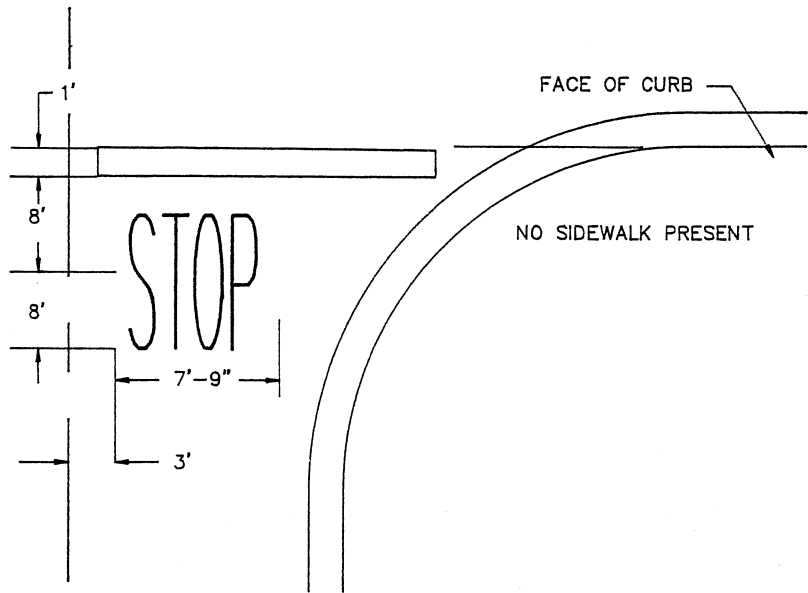
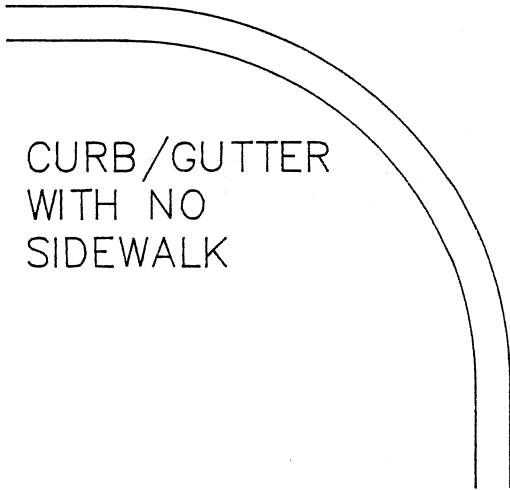

CURB/GUTTER WITH SIDEWALK

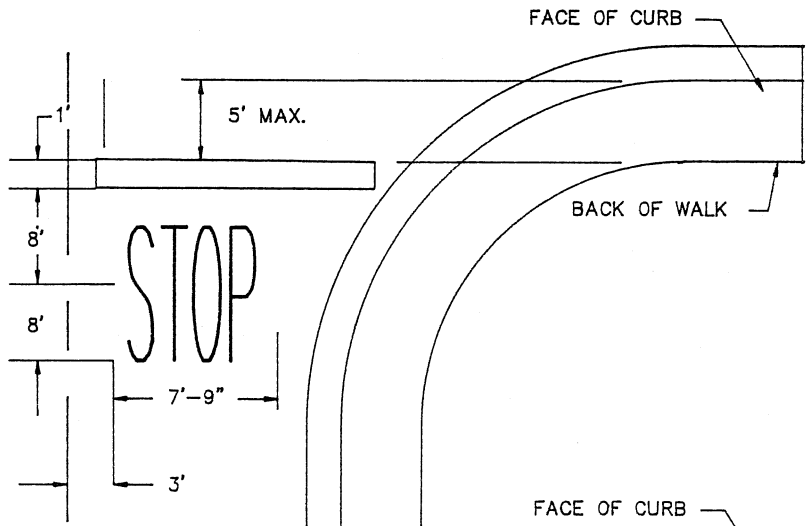
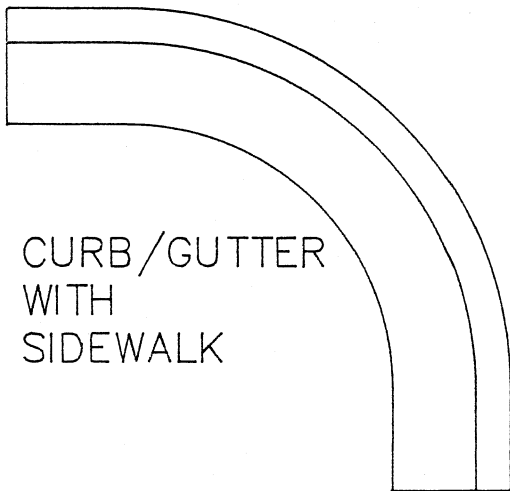

CURB/GUTTER WITH SIDEWALK & PLANTER STRIP

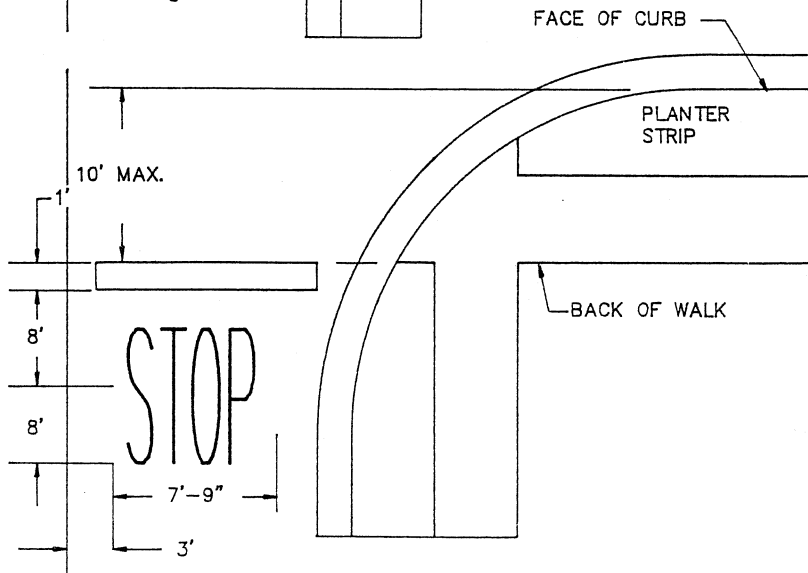
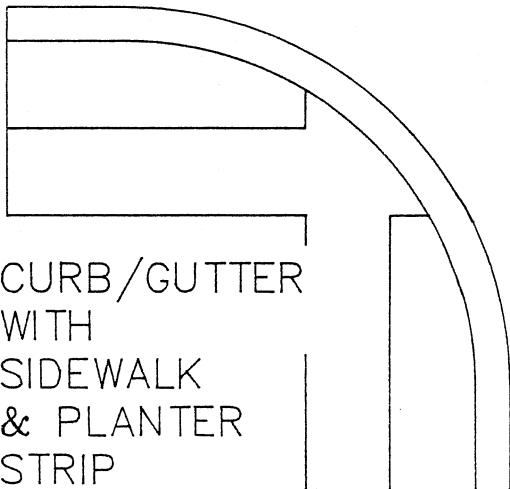

LIMIT LINE PLACEMENT

CITY OF HOLLISTER

STANDARD PLANS

APPROVED: *[Signature]*

MAX H. BRIDGES R.C.E. 24152 - EXP. 12/31/93

DATE	APRIL 30, 1992
REVISED	
DETAIL	A-12-2

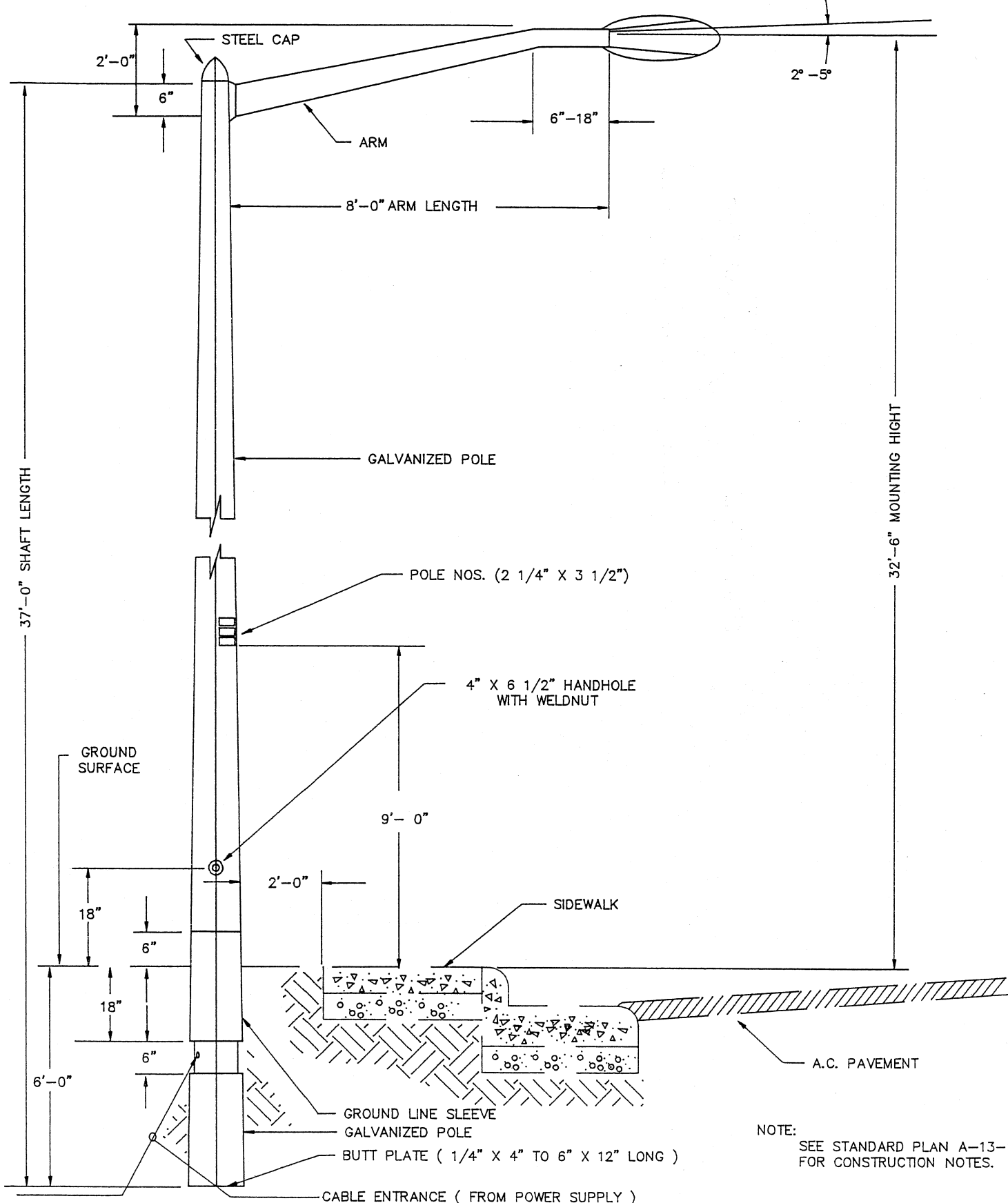

NOTE: SEE STANDARD PLAN A-13-2 FOR CONSTRUCTION NOTES.

# STREET LIGHT POLE INSTALLATION

## CITY OF HOLLISTER

STANDARD PLANS

APPROVED: *[Signature]*

MAX H. BRIDGES R.C.E. 24152- EXP. 12/31/93

DATE	APRIL 30, 1992
REVISED	
DETAIL	A-13-1 SHEET 1 OF 2

NOTES:

1. THE MINIMUM CLEARANCE BETWEEN STREET LIGHTS AND FIRE HYDRANTS, DRIVEWAYS, WATER SERVICES OR SANITARY SEWER SERVICES SHALL BE 5 FEET.
2. THE CONTRACTOR SHALL INSTALL INTERNAL WIRING FROM THE HANDHOLE TO THE POLE ARM USING (2) TWO 10 Ga. SOLID COPPER CONDUCTORS WITH THHN/THW 600V RATED INSULATION. PROVIDE A 12 INCH LOOP AT EACH THE HANDHOLE AND THE POLE ARM.
3. THE CONTRACTOR SHALL AFFIX THE STREET LIGHT POLE NUMBERS. THE NUMBERS SHALL BE SCOTCHLITE REFLECTIVE NUMERALS AND SHALL FACE THE STREET.
4. THE BOTTOM OF THE POLE HOLES SHALL BE TAMPED PRIOR TO INSTALLING THE POLE. THE CONTRACTOR SHALL PULL THE POWER CABLE THROUGH THE ENTRANCE LOCATED AT THE BOTTOM OF THE GROUND LINE SLEEVE TO THE HAND HOLE. AFTER INSTALLATION OF THE POLE, BACKFILL WITH SAND IN 12 INCH LIFTS. THE TOP 12 INCHES SHALL BE NATIVE SOIL.
5. ALL STREET LIGHT POLES SHALL BE MANUFACTURED BY BY AMERON, VALMONT OR APPROVED OTHER TO THE SPECIFICATIONS SHOWN ON STANDARD PLAN A-13-1.
6. THE DEVELOPER WILL INSTALL THE LUMINAIRES AND PHOTOCELLS AS PER PACIFIC GAS ELECTRIC COMPANY SPECIFICATIONS.
7. THE DEVELOPER WILL ASSUME ALL COSTS IN INSTALLING WIRING AND CONDUIT AS REQUIRED BY THE PACIFIC GAS AND ELECTRIC COMPANY IN ACCORDANCE WITH THE LS-2C RATE SCHEDULE.
8. THE DEVELOPER WILL REIMBURSE THE PACIFIC GAS AND ELECTRIC COMPANY FOR "CONNECTING" THE STREET LIGHTS IN ACCORDANCE WITH THE LS-2C RATE SCHEDULE.
9. THE PACIFIC GAS AND ELECTRIC COMPANY WILL ENERGIZE THE STREET LIGHTS UPON NOTIFICATION FROM THE CITY OF HOLLISTER ENGINEERING DEPARTMENT.
10. ALL LUMINAIRES ARE TO BE 120 VOLTS AND THE REACTOR TYPE UNLESS OTHERWISE SPECIFIED.
11. ALL PHOTO ELECTRIC CELLS SHALL BE THE TWIST LOCK TYPE.
12. THE FOLLOWING LUMINAIRES AND PHOTOCELLS ARE APPROVED BY P.G. & E. WITH THE APPROPRIATE CODE #S

LUMINAIRE/P.G.&E. CODE	LAMP SIZE/P.G.&E. CODE	PHOTOCNTROL/R.G.&E. CODE
70 WATT / 35-0378	70 WATT / 45-2093	35-0869
150 WATT / 35-0288	150 WATT / 45-2091	SAME
100 WATT / 35-0281	100 WATT / 45-2090	SAME
200 WATT / 35-0795	200 WATT / 45-2094	SAME

STREET LIGHT POLE INSTALLATION NOTES

CITY OF HOLLISTER  
STANDARD PLANS

APPROVED: Clint Quilter 5/20/98  
CITY ENGINEER- CLINT QUILTER RCE# 57570 EXP. 12/31/97

DRAWN BY: <u>L.E.</u>	DATE: <u>5/20/98</u> SEPTEMBER 02, 1997
REVISED: <u>MAY 20 '98</u>	CHECKED BY:
DETAIL	A-13-2 SHEET 2 OF 2

FACE OF CURB  
LAYOUT LINE OF BARRICADE

RIGHT-OF-WAY TERMINATION

8'-0" MAX.

8'-0" MAX.

8'-0" MAX.

8'-0" MAX.

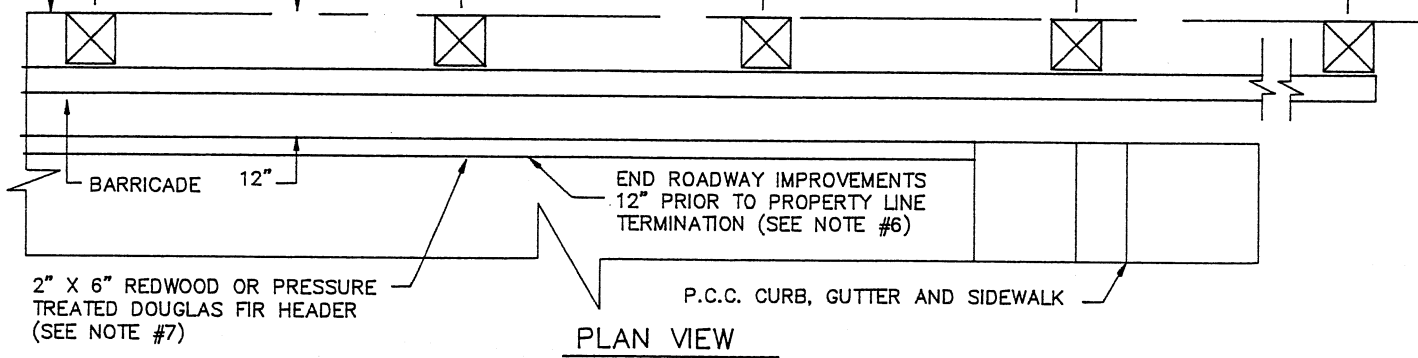

2" X 6" REDWOOD OR PRESSURE TREATED DOUGLAS FIR HEADER (SEE NOTE #7)

P.C.C. CURB, GUTTER AND SIDEWALK

PLAN VIEW

FACE OF CURB

TYPE NR MARKER (TYP)

10'-0" MAX. O.C.

12'-0" MAX.

2"

4" X 4" REDWOOD OR PRESSURE TREATED DOUGLAS FIR POST (TYP)

3'-4"

HIGHT FORM TOP OF CURB

1'-5"

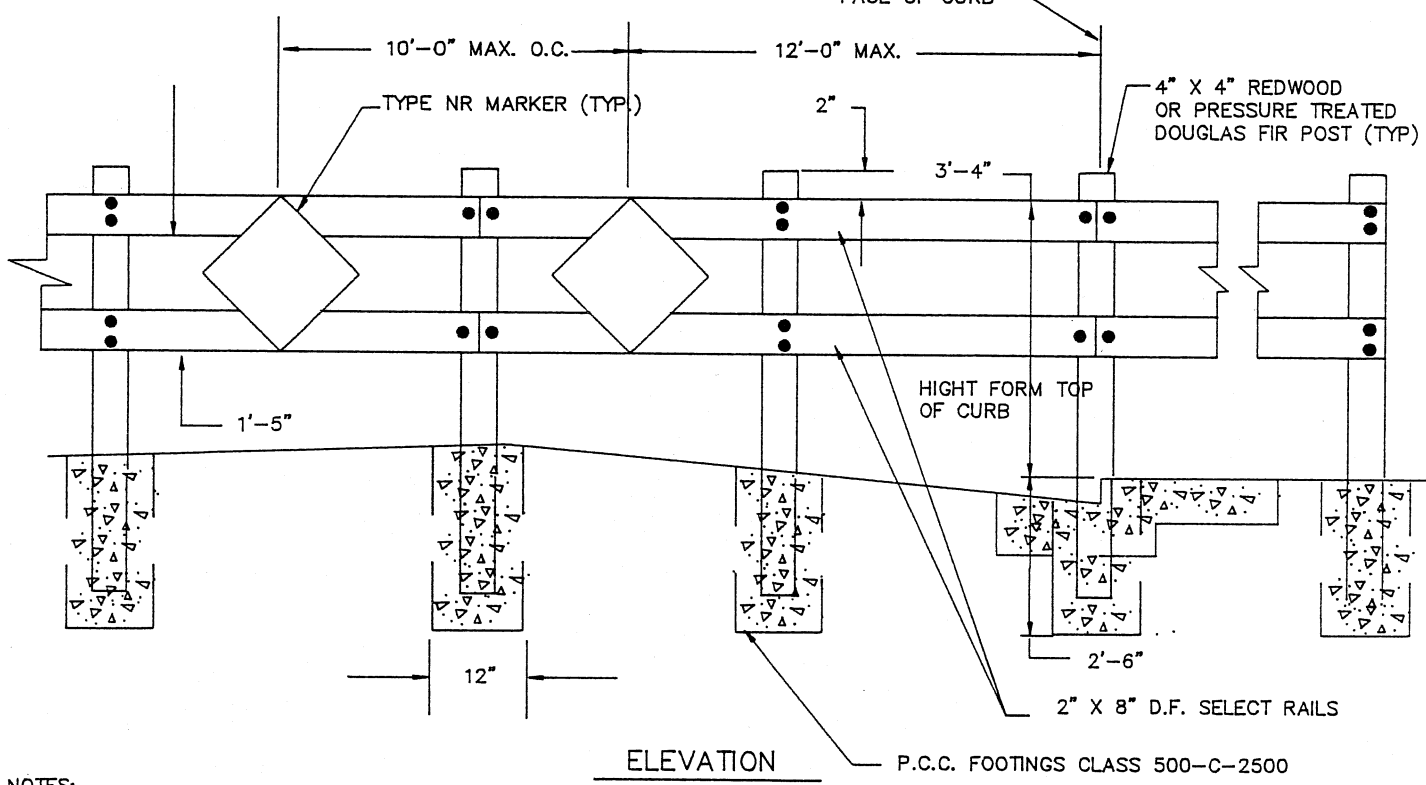

2" X 8" D.F. SELECT RAILS

ELEVATION

P.C.C. FOOTINGS CLASS 500-C-2500

NOTES:

1. INSTALL 4" X 4" REDWOOD OR PRESSRE TREATED DOUGLAS FIR POSTS AT NO MORE THAN 8' O.C. IN 12" DIAMETER P.C.C. FOOTINGS. CUT POST TOPS WITH 1/2" SLOPE TO THE REAR OF THE BARRICADE.
2. RAILS SHALL BE 2" X 8" X 16' LONG DOUGLAS OF SELECT GRADE.
3. ATTACH RAILS WITH 1/2" X 6" GALVANIZED CARRIAGE BOLTS. USE 2 PER RAIL AT EACH POST.
4. PAINT ALL EXPOSED WOOD WITH ONE COAT OF EXTERIOR WOOD PRIMER AND TWO COATS OF EXTERIOR WHITE HI-GLOSS ENAMEL.
5. INSTALL 18" X 18" TYPE NR (RED REFLECTIVE BACKGROUND) MARKERS ACROSS THE FULL WIDTH Oead END STREETS. INSTALL 18" X 18" TYPE NY (YELLOW REFLECTIVE BACKGROUND) AS REQUIRED BY THE PUBLIC WORKS INSPECTOR IN ALL OTHER CASES.
6. ALL IMPROVEMENTS SHALL EXTEND TO THE PHASE LINE ON PHASED PROJECTS AND THE PROPERTY LINE ON NON-PHASED PROJECTS.
7. WITH THE APPROVAL OF THE PUBLIC WORKS INSPECTOR, HEADER BOARD MAY BE ELIMINATED ON PHASED DEVELOPMENTS PROVIDED SUBGRADE PREPARATION, BASE ROCK BASE ROCK AND PAVEMENT ARE EXTENDED 12" BEYOND THE CURB AND GUTTER LIMITS.

STREET BARRICADE

CITY OF HOLLISTER

STANDARD PLANS

APPROVED:

MAX H. BRIDGES R.C.E. 24152- EXP. 12/31/93

DATE

APRIL 30, 1992

REVISED

DETAIL

A-14

SHEET 1 OF 1

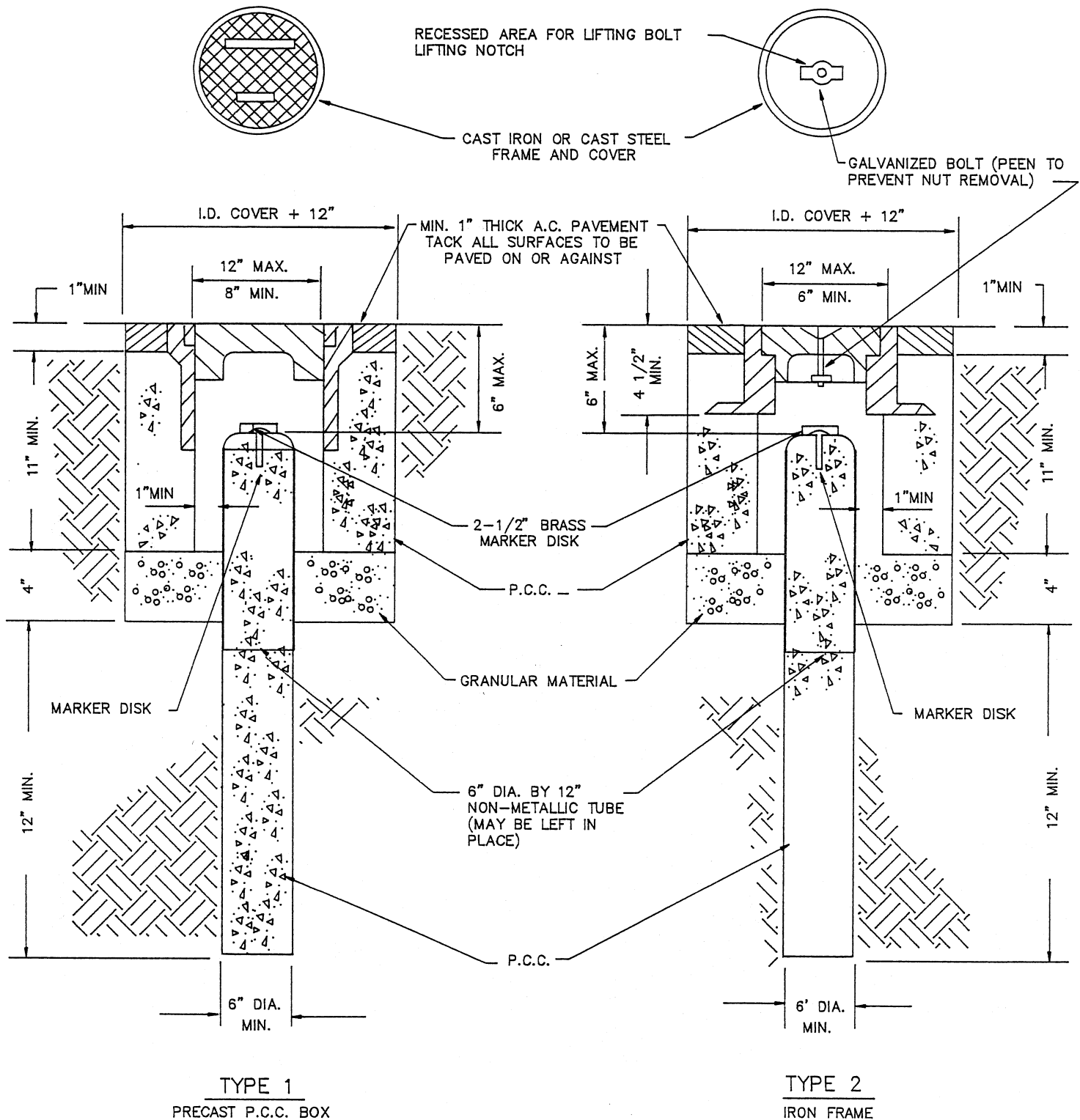

NOTES:

1. THE CONFIGURATION OF THE CAST IRON OR CAST STEEL FRAME AND COVER MAY VARY FROM THAT SHOWN.
2. FRAME SHALL BE EMBEDDED IN CONCRETE A MINIMUM OF 3".
3. ALL P.C.C. SHALL BE CLASS 520-C-2500.
4. COVER TO BE CAST WITH WORDS "MONUMENT" OR "CITY MONUMENT".

MONUMENT

CITY OF HOLLISTER  
STANDARD PLANS

APPROVED: \_\_\_\_\_

MAX H. BRIDGES R.C.E. 24152- EXP. 12/31/93

DATE APRIL 30, 1992

REVISED \_\_\_\_\_

DETAIL

A-15

SHEET 1 OF 1

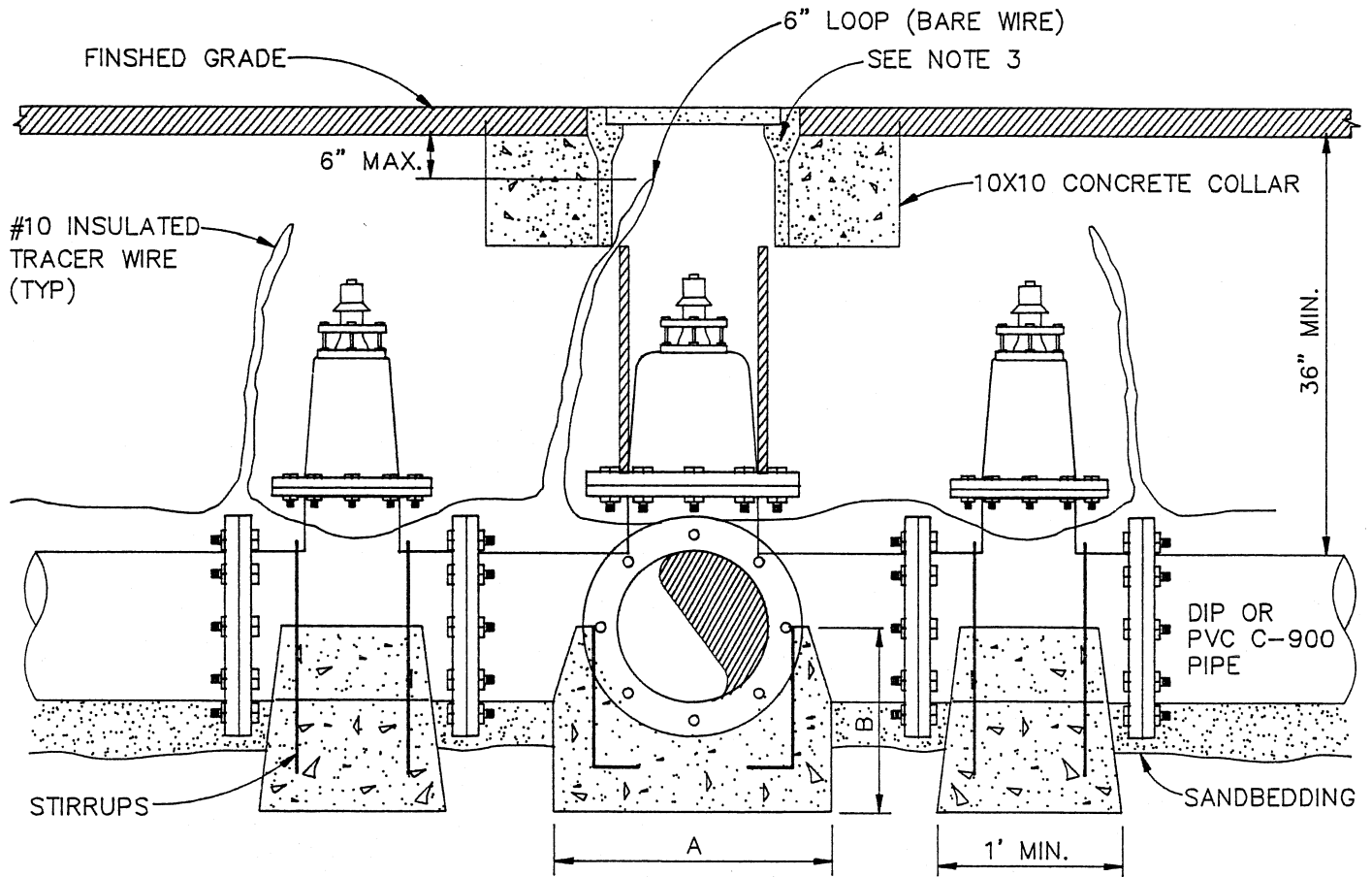

#10 INSULATED TRACER WIRE (TYP)

FINISHED GRADE

6" LOOP (BARE WIRE)

SEE NOTE 3

6" MAX.

10X10 CONCRETE COLLAR

36" MIN.

DIP OR PVC C-900 PIPE

STIRRUPS

SANDBEDDING

A

1' MIN.

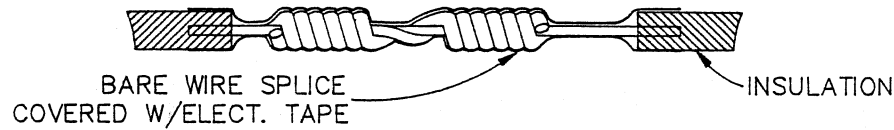

GATE VALVE SIZE	ANCHOR BLOCK DIMENSIONS	
	A (FT)	B (FT)
6	1.50	1.00
8	1.50	1.00
10	2.00	1.50
12	2.00	1.50

## STANDARD WATER VALVE

CITY OF HOLLISTER  
STANDARD PLANS

APPROVED:

*Max H. Bridges*  
MAX H. BRIDGES R.C.E. 24152- EXP. 12/31/93

DATE

APRIL 30, 1992

REVISED

DETAIL

B-2

SHEET 1 OF 1



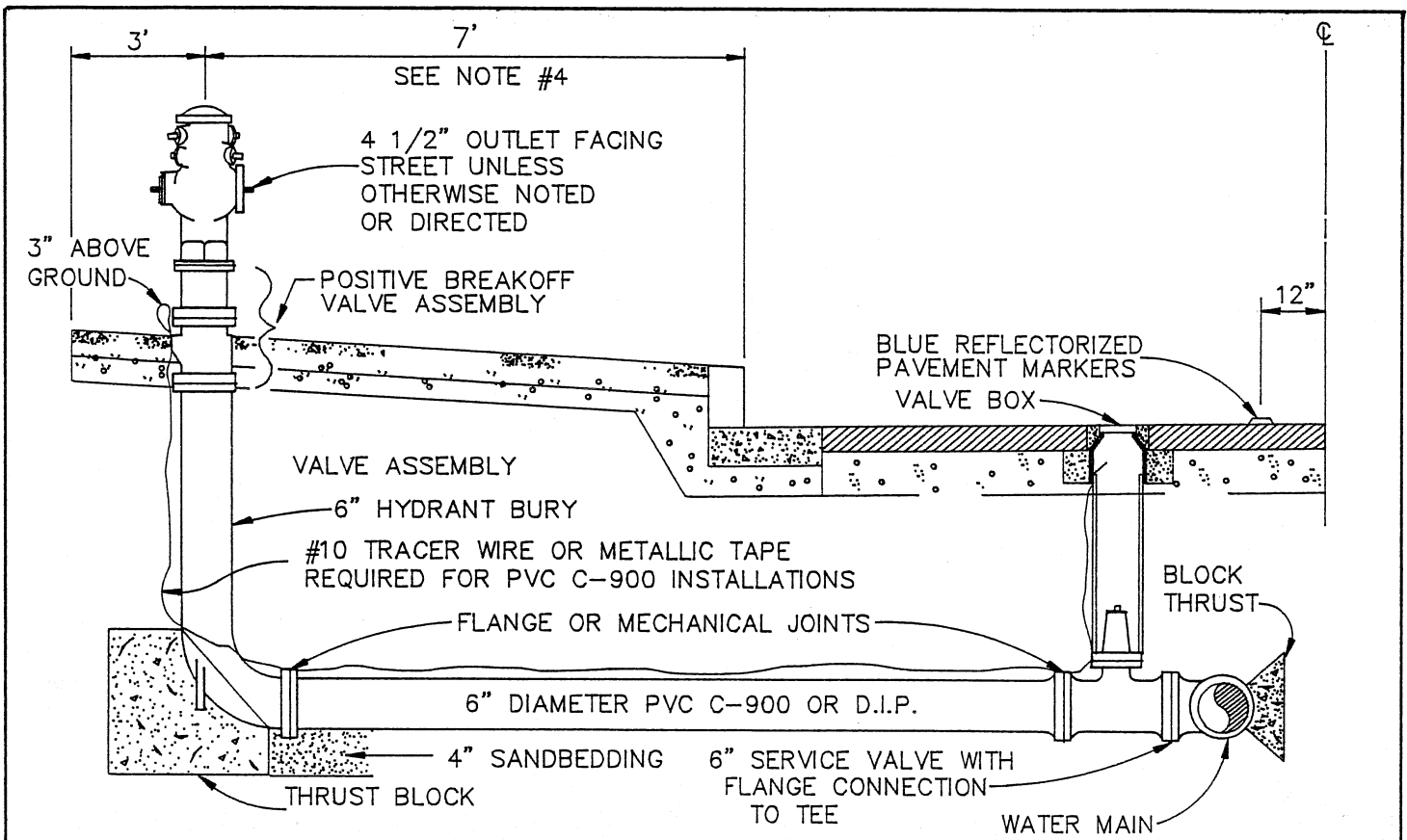

NOTES.

1. HYDRANT SHALL HAVE 1 - 4 1/2" NST PUMPER OUTLET AND 2 - 2 1/2" NST HOSE OUTLETS, AND SHALL BE LONG BEACH MODEL 430, CLOW MODEL 860, OR APPROVED EQUAL.
2. POSITIVE BREAKOFF VALVE ASSEMBLY SHALL BE LONG BEACH LB-400 DUCTILE IRON OR APPROVED EQUAL.
3. COMPANION VALVE SHALL BE A CITY STANDARD GATE VALVE. SEE DETAIL B-2. THRUST BLOCK SHALL HAVE A MINIMUM BEARING SURFACE OF 8 SQUARE FEET.
4. FOR STANDARD 5' SIDEWALK, CONCRETE PAD SHALL 4'-6" X 5' AND SHALL SLOPE AT 2% TOWARD THE STREET. CONCRETE SHALL BE CLASS 520-C-2500 AND SHALL FINISHED TO SIDEWALK SPECIFICATIONS. IN AREAS WITH EXISTING PARK STRIP, THE HYDRANT SHALL BE 3' FROM THE FACE OF CURB.
5. HYDRANT ASSEMBLY SHALL PASS HYDRO-STATIC, LEAKAGE, DISINFECTION AND FIRE FLOW TESTS PER CITY STANDARDS.
6. HYDRANTS SHALL BE LOCATED AS SHOWN ON THE PLANS APPROVED BY THE CITY ENGINEER AND MUST HAVE A MINIMUM OF 5' CLEARANCE FROM ANY DRIVEWAY.
7. WHEN A HYDRANT IS LOCATED AT AN INTERSECTION, BLUE REFLECTORIZED MARKERS SHALL BE PLACED ON EACH STREET.

## FIRE HYDRANT ASSEMBLY

CITY OF HOLLISTER  
STANDARD PLANS

APPROVED: \_\_\_\_\_

MAX H. BRIDGES R.G.E. 24152- EXP. 12/31/93

DATE	APRIL 30, 1992
REVISED	
DETAIL	B-1 SHEET 1 OF 1

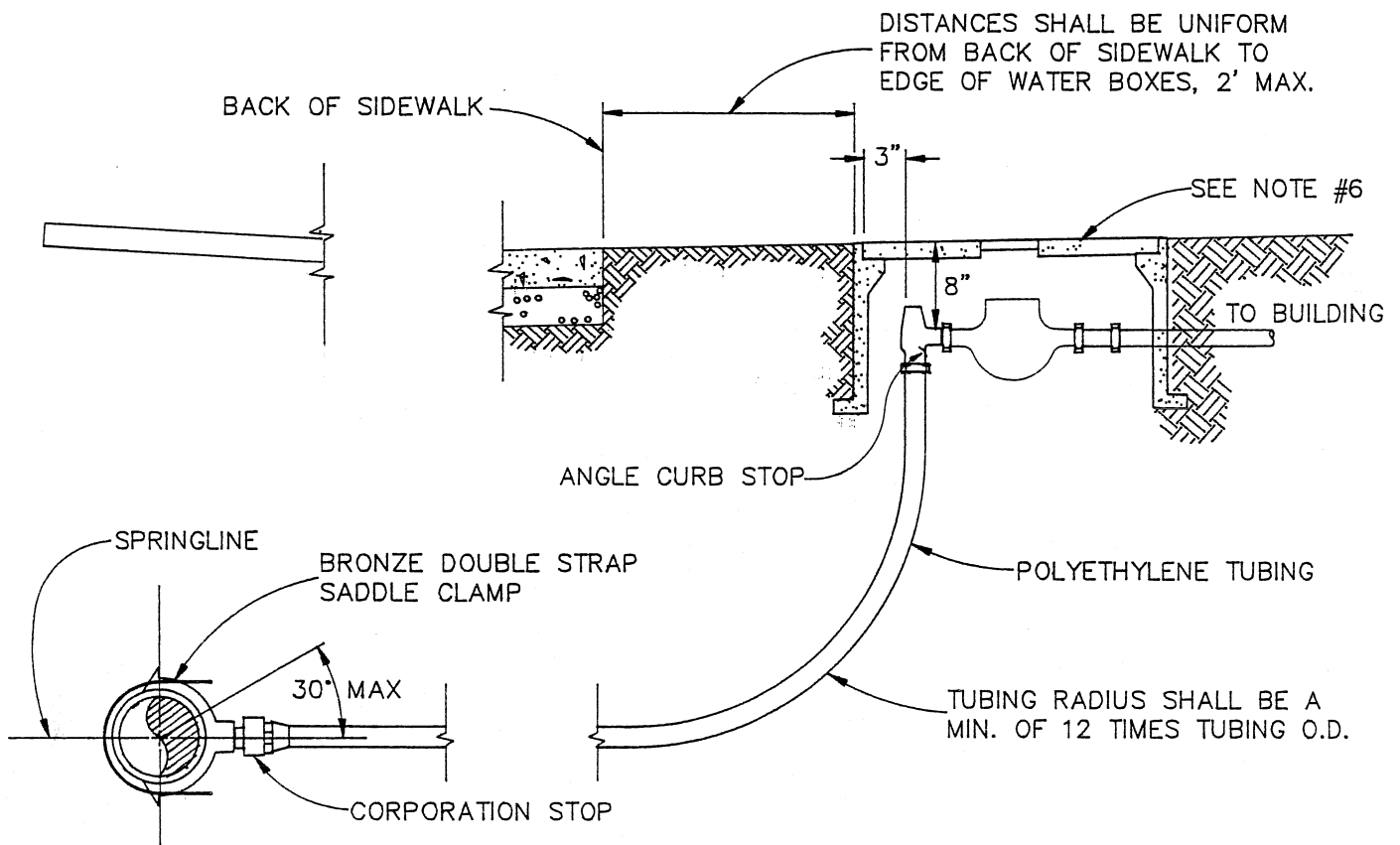

NOTES:

1. ALL WATER SERVICE INSTALLATIONS INCLUDE METER BOX AND MUST BE MARKED WITH A "W" ON CURB FACE.
2. MINIMUM 1" DIAMETER CTS WATER SERVICE WITH 1" ANGLE CURB STOP FORD, MUELLER OR JONES.
3. ALL WATER SERVICES SHALL HAVE A HAND TAMPED SAND BEDDING 9" BENEATH THE TUBING AND SHALL HAVE 6" MINIMUM CLEARANCE ON EACH SIDE.
4. ALL WATER SERVICES SHALL BE POLYETHYLENE CTS SDR 9 (ASTM D2737) TUBING.
5. CORPORATION STOP SHALL BE FORD, MUELLER OR JONES.
6. WATER METER BOX SHALL BE CHRISTY B12 WITH B12 G LID OR APPROVED EQUAL.
7. A MINIMUM CLEARANCE OF 12" BETWEEN WATER SERVICES REQUIRED ON COMMON TRENCH.
8. ALL TUBING CONNECTIONS SHALL BE THE COMPRESSION TYPE: FORD "PACK JOINT", MUELLER "INSTA-TITE" OR EQUAL.

WATER SERVICE

CITY OF HOLLISTER  
STANDARD PLANS

APPROVED:

*Max H. Bridges*  
MAX H. BRIDGES R.C.E. 24162- EXP. 12/31/93

DATE	APRIL 30, 1992
REVISED	
DETAIL	B-3
SHEET 1 OF 1	

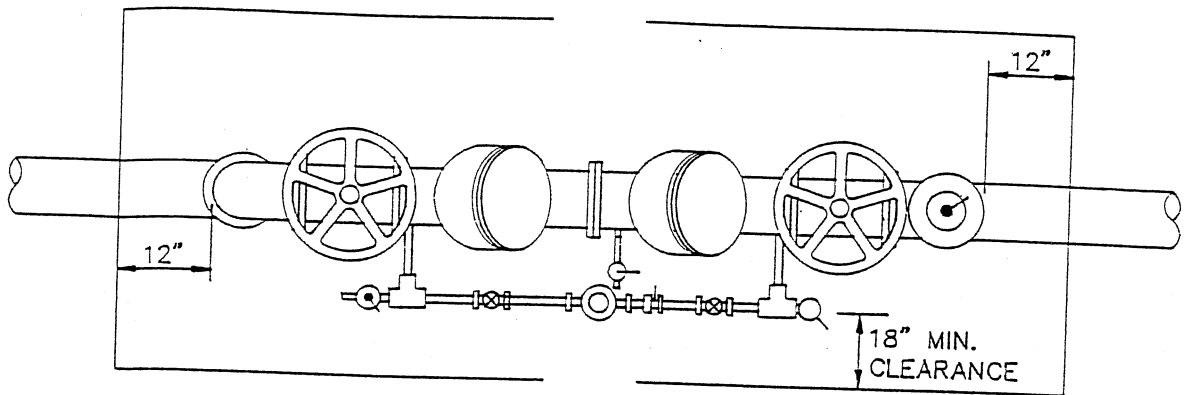

TOP VIEW

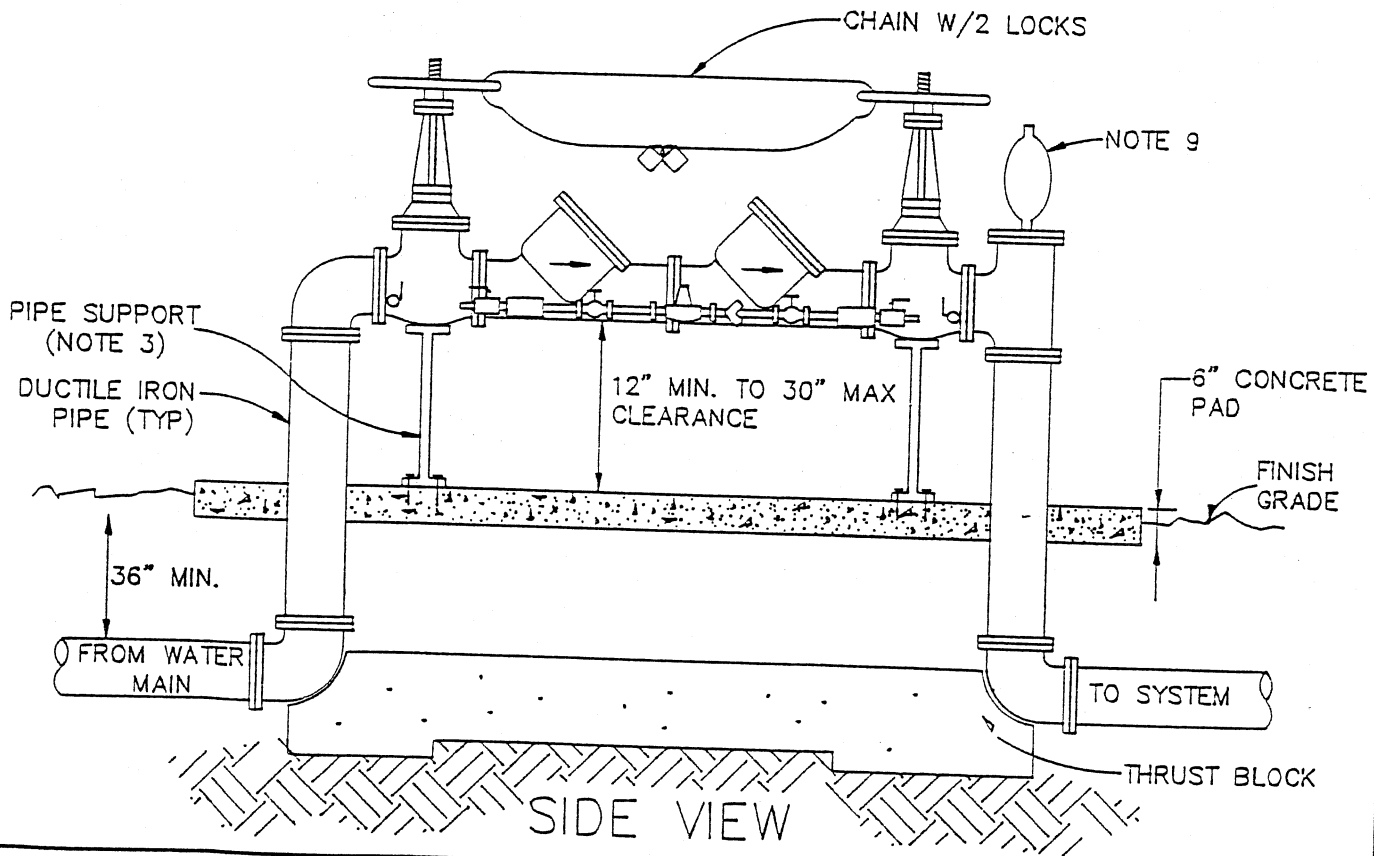

SIDE VIEW

BACKFLOW PREVENTION ASSEMBLY  
FOR FIRE PREVENTION SYSTEM

CITY OF HOLLISTER  
STANDARD PLANS

APPROVED:

*Max H. Bridges*  
MAX H. BRIDGES R.C.E. 24152 - EXP. 12/31/93

DATE	APRIL 30, 1992
REVISED	
DETAIL	B-4-1 SHEET 1 OF 2

NOTES:

1. DOUBLE DETECTOR CHECK VALVE BACKFLOW PREVENTION ASSEMBLIES SHALL BE FEBCO MODEL 806 DDC, AMES MODEL DCDA 3000 OR APPROVED EQUAL. ENTIRE ASSEMBLIES INCLUDING GATE VALVES, TEST COCKS AND BYPASS METER SHALL BE PROVIDED AS A COMPLETE UNIT.
2. TEST COCKS FOR BACKFLOW PREVENTERS SHALL BE PROVIDED WITH STANDARD 3/4" IRON PIPE BY MALE GARDEN HOSE THREAD ADAPTERS.
3. BACKFLOW PREVENTERS SHALL BE SUPPORTED BY 2" DIAMETER GALVANIZED STEEL PIPE SADDLE SUPPORTS WITH FLANGE ADAPTERS BOLTED TO CONCRETE PAD. PAINT THE ASSEMBLY WITH COLOR MATCHING THE BACKFLOW PREVENTER.
4. ALL MECHANICAL BACKFLOW PREVENTION DEVICES SHALL CONFORM TO THE LATEST REVISION OF THE CALIFORNIA DEPARTMENT OF HEALTH SERVICES APPROVED LIST FOR CROSS-CONNECTION.
5. NO TEES OR OTHER CONNECTIONS SHALL BE ALLOWED BETWEEN THE PUBLIC WATER SUPPLY AND BACKFLOW PREVENTER ASSEMBLY. INSTALL BACKFLOW PREVENTER ASSEMBLY AS CLOSE AS PRACTICABLE TO THE WATER MAIN.
6. O.S.&Y. VALVES REQUIRED ON FIRE SERVICE (U.L. LISTED) RATED 175 PSI WORKING AND 350 PSI HYDROSTATIC TEST PRESSURE. HAND WHEELS ON O.S.&Y. VALVES SHALL BE CHAINED AND LOCKED. USE 3/8" GALVANIZED CHAIN WITH LOCK BETWEEN VALVES. CHAIN SHALL BE DOUBLE LOCKED, ONE LOCK WILL BE SUPPLIED BY THE CITY OF HOLLISTER.
7. THRUST BLOCK SHALL BE CLASS 420-C-2000 P.C.C.
8. ASSEMBLY SHALL BE PROTECTED BY GUARD POSTS FILLED WITH CONCRETE WHEN LOCATED NEAR TRAFFIC OR AS OTHERWISE DIRECTED BY THE CITY ENGINEER.
9. AIR RELEASE VALVE SHALL BE APCO NO. 50, 1/2" FOR 3" TO 6" SERVICES AND 3/4" FOR 8" TO 12" SERVICES.
10. DEVICE MUST BE ACCESSIBLE FOR TESTING AND MAINTAINANCE.
11. REQUIRE TEST OF BACKFLOW PREVENTION DEVICE BY A CERTIFIED INDIVIDUAL PRIOR TO ACCEPTANCE.
12. ALL ASSEMBLIES SHALL BE PROTECTED BY AN ENCLOSURE. SEE STANDARD PLAN NO. B-5

**BACKFLOW PREVENTION ASSEMBLY**  
FOR FIRE PREVENTION SYSTEM

CITY OF HOLLISTER  
STANDARD PLANS

APPROVED: *Max H. Bridges*  
MAX H. BRIDGES R.C.E. 24152- EXP. 12/31/93

DATE	APRIL 30, 1992
REVISED	
DETAIL B-4-2	
SHEET 2 OF 2	

# FRONT VIEW

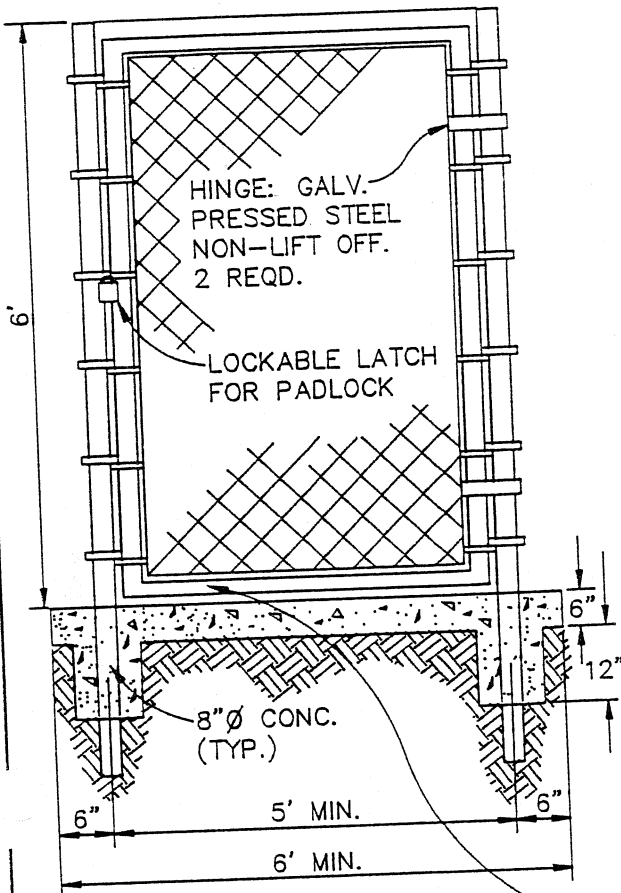

# SIDE VIEW

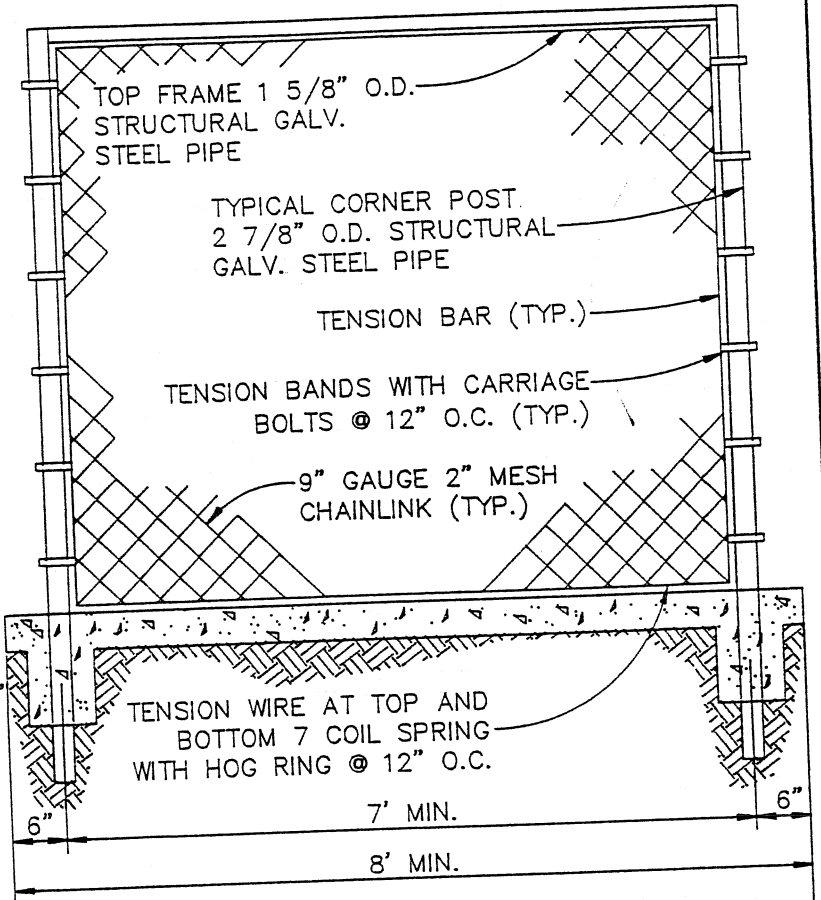

1 5/8" O.D. STRUCTURAL PIPE GATE FRAME  
GALV. STEEL, WELDED ALL CORNERS

## NOTES:

1. GATE TO BE ON END OF CLOSURE.
2. WHERE TWO B.P.D.'S ARE INSTALLED PARALLEL, ENCLOSURE IS TO BE TWICE THE WIDTH SHOWN, AND SUPPLIED WITH DOUBLE GATE WITH DOUBLE DROP ROD FOR LATCHING.
3. ALL ENCLOSURES TO HAVE CHAIN LINK TOPS.
4. CONCRETE PAD TO BE 520-C-2500 P.C.C.. TOP OF PAD TO BE LEVEL, AND SET 2" MINIMUM ABOVE EXISTING SOIL LEVEL.
5. BROOM FINISH ON CONCRETE PAD.

# BACKFLOW PREVENTION ASSEMBLY ENCLOSURE FOR FIRE PREVENTION SYSTEM

CITY OF HOLLISTER  
STANDARD PLANS

APPROVED:

*Max H. Bridges*  
MAX H. BRIDGES C.E. 24152- EXP. 12/31/93

DATE	APRIL 30, 1992
REVISED	
DETAIL	B-5

SHEET 1 OF 1

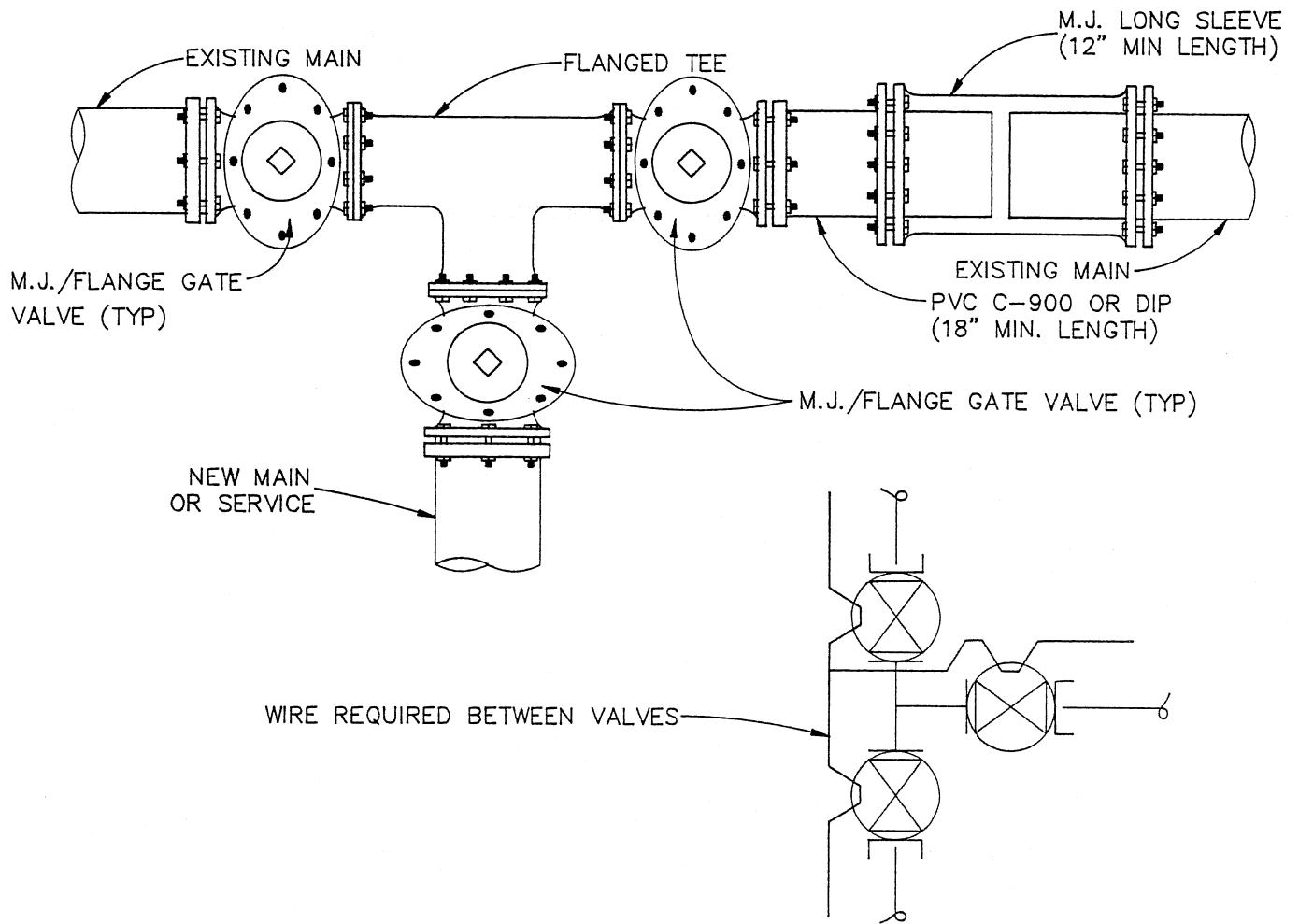

NOTES:

1. NOTIFY PUBLIC WORKS INSPECTOR 72 HRS. MIN. PRIOR TO WATER TIE-IN ON EXISTING WATER MAIN. MAIN SHUT-DOWN WILL BE COORDINATED BY PUBLIC WORKS INSPECTOR.
2. ALL EXISTING VALVES TO BE OPERATED BY APPROPRIATE AGENCY.
3. ALL FITTINGS SHALL BE CAST IRON.
4. POUR THRUST BLOCKS AS PER STANDARD PLAN B-11.
5. ALL PIPES & FITTINGS SHALL BE DISINFECTED WITH LIQUID CHLORINE PRIOR TO INSTALLATION PER CITY STANDARDS.
6. ALL FITTINGS MUST BE ONSITE AND ALL FITTINGS EXCEPT M.J. LONG SLEEVE TO BE ASSEMBLED PRIOR TO WATER SYSTEM SHUT-DOWN.

WATER TIE-IN DETAIL W/VALVE CLUSTER

CITY OF HOLLISTER  
STANDARD PLANS

APPROVED: *Max H. Bridges*  
MAX H. BRIDGES R.C.E. 24152- EXP. 12/31/93

DATE	APRIL 30, 1992
REVISED	
DETAIL	B-6
SHEET 1 OF 1	

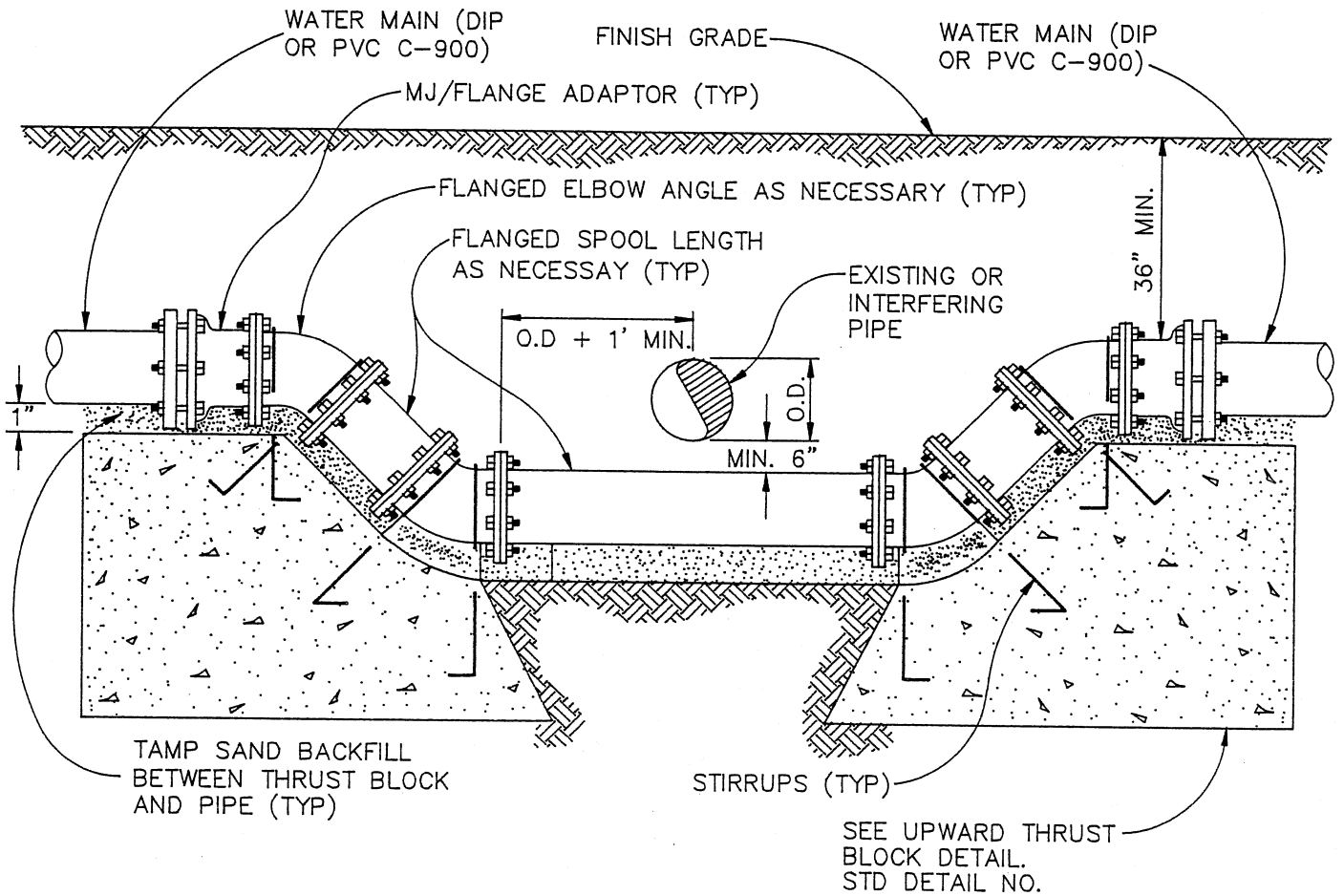

NOTES:

1. FLANGES, NUTS & BOLTS TO BE CLEAR OF CONCRETE.
2. ALL ELBOWS SHALL BE CAST IRON.
3. ALL SPOOLS SHALL BE DUCTILE IRON WITH PLOYWRAP OR BITUMINOUS COATING.
4. ALL EXPOSED STIRRUPS SHALL BE PAINTED WITH TWO COATS OF KOPPERS 505, TNE MEC 46-450, AMERON OR EQUAL 15 MILS EACH COAT
5. THRUST BLOCKS SHALL BE CLASS 420-C-2000 P.C.C.
6. CONCRETE SHALL NOT COME IN CONTACT WITH PVC PIPE.
7. ANY ALTERNATIVES TO THE PREFERRED FLANGE FITTING OFFSET SHALL REQUIRE ENGINEERING DEPARTMENT REVIEW AND APPROVAL.
8. STIRRUPS TO BE #4 REBAR.

WATER MAIN VERTICAL OFFSET

CITY OF HOLLISTER  
STANDARD PLANS

APPROVED:

*Max H. Bridges*  
MAX H. BRIDGES R.C.E. 24152- EXP. 12/31/93

DATE	APRIL 30, 1992	
REVISED		
DETAIL	B-7	SHEET 1 OF 1

DISTANCES SHALL BE UNIFORM FROM BACK OF SIDEWALK TO EDGE OF WATER BOXES, 2' MAX.

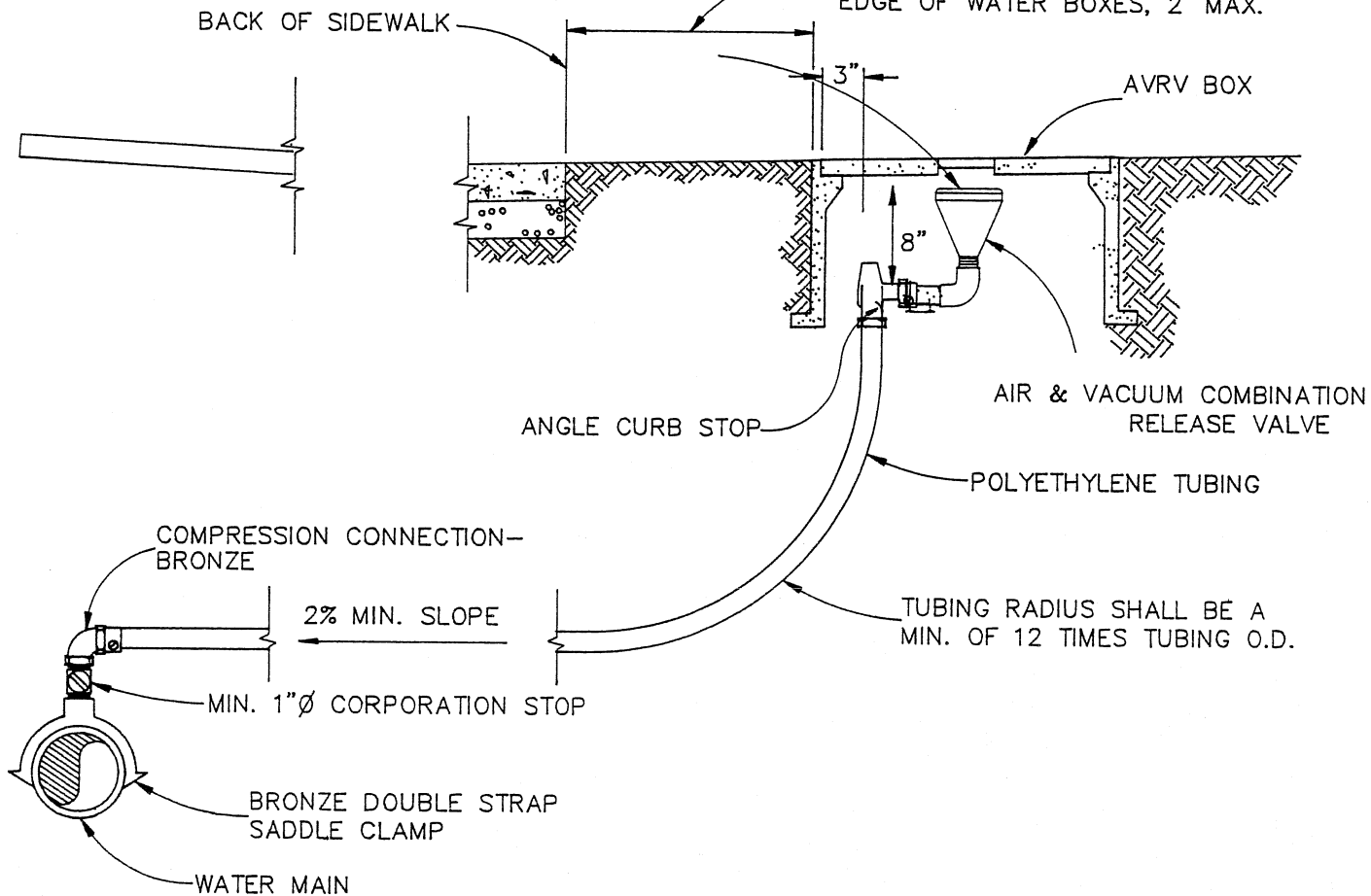

NOTES:

1. INSTALL AIR AND VACUUM COMBINATION RELEASE VALVE ASSEMBLY AT THE HIGH POINT ON WATER MAIN.
2. AIR AND VACUUM COMBINATION RELEASE VALVE ASSEMBLY SHALL BE 1" DIAMETER MINIMUM APCO OR APPROVED EQUAL.
3. AIR AND VACUUM COMBINATION RELIEF VALVE BOX SHALL BE CHRISTY B36 WITH FL36D LID OR APPROVED EQUAL.

AIR AND VACUUM COMBINATION RELEASE VALVE ASSEMBLY

CITY OF HOLLISTER  
STANDARD PLANS

APPROVED: \_\_\_\_\_

MAX H. BRIDGES R.C.E. 24152- EXP. 12/31/93

DATE	APRIL 30, 1992
REVISED	
DETAIL	B-8



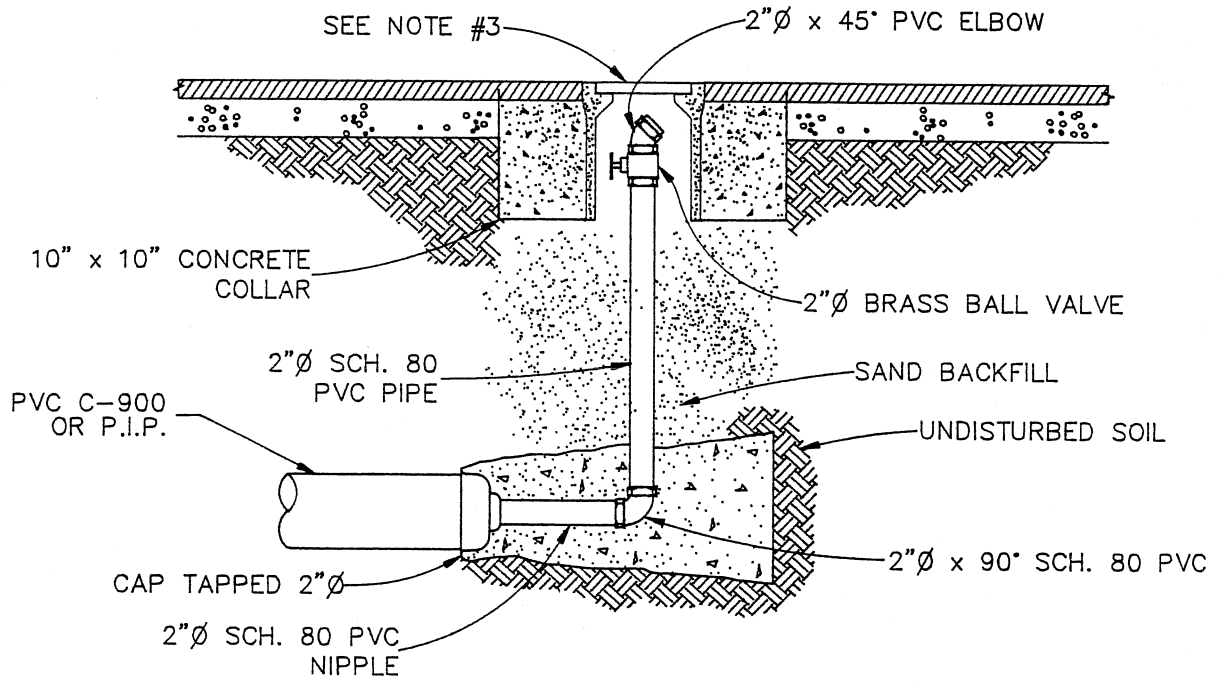

FOR 8"Ø AND SMALLER WATER MAIN

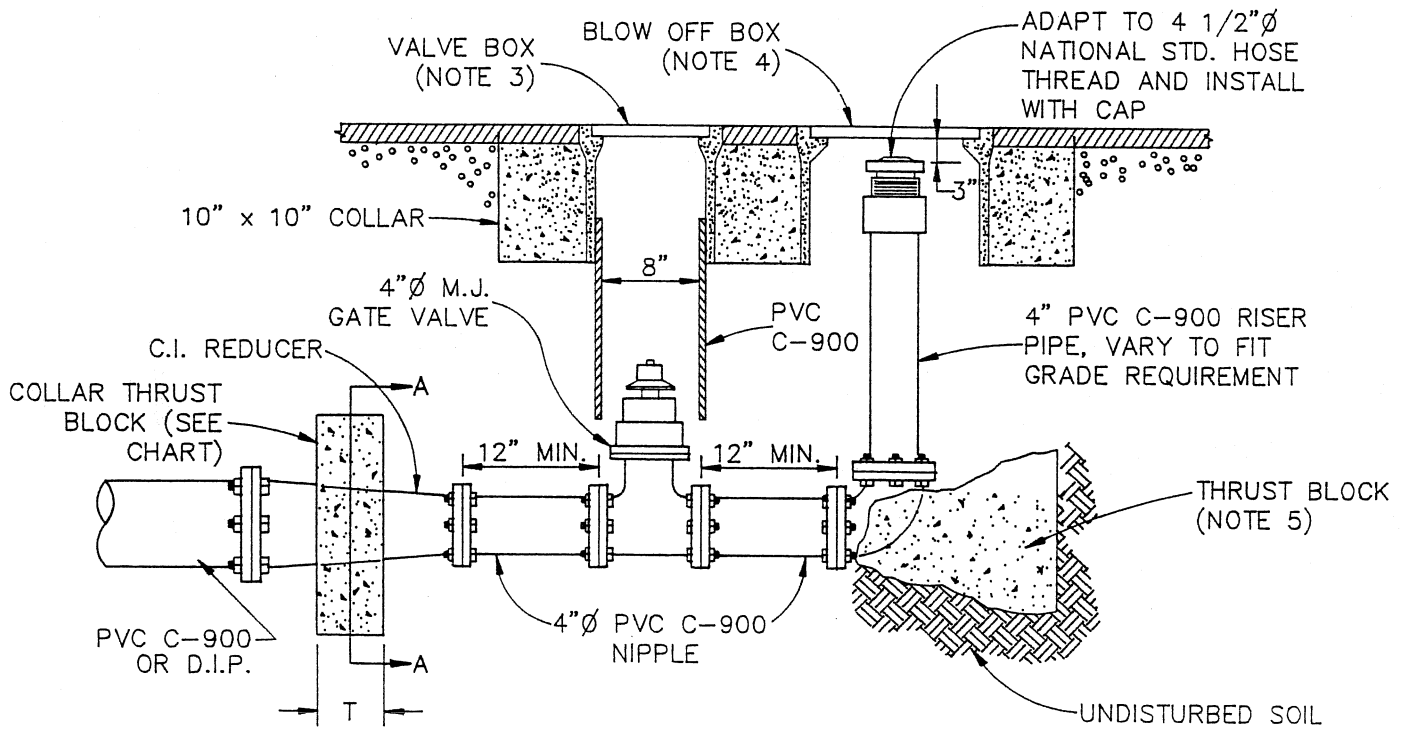

FOR 10"Ø AND LARGER WATER MAIN

BLOW OFF VALVE ASSEMBLY

CITY OF HOLLISTER  
STANDARD PLANS

APPROVED:

*Max H. Bridges*  
MAX H. BRIDGES R.C.E. 24152- EXP. 12/31/93

DATE **APRIL 30, 1992**

REVISED

DETAIL **B-9-1**

SHEET 1 OF 2

REDUCERS	COLLAR THRUST BLOCK	
	T (in.)	BEARING AREA (s.f.)
10"Ø x 4"Ø	6"	9
12"Ø x 4"Ø	8"	13

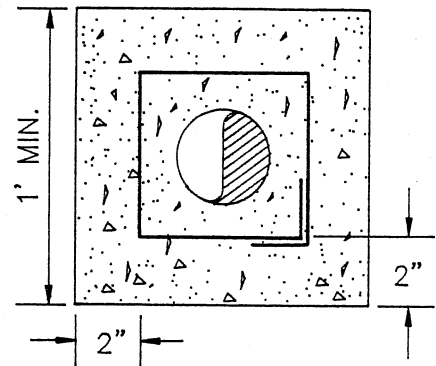

SECTION A - A

NOTES:

1. ALL P.V.C. PIPES SHALL BE A.W.W.A. C-900 CLASS 150 OR SCH. 80 AS NOTED.
2. CONCRETE COLLAR AND THRUST BLOCK SHALL BE CLASS 420-C-2000 P.C.C.
3. VALVE BOX SHALL BE CHRISTY G5 BOX WITH G5C TRAFFIC LID OR APPROVED EQUAL.
4. BLOW OFF BOX SHALL BE CHRISTY G8 WITH G5C TRAFFIC LID OR APPROVED EQUAL.
5. THRUST BLOCK ON THE 90° ELBOW SHALL HAVE A MINIMUM BEARING SURFACE OF 4 SQUARE FEET.

BLOW OFF ASSEMBLY

CITY OF HOLLISTER  
STANDARD PLANS

APPROVED: \_\_\_\_\_

MAX H. BRIDGES R.C.E. 24152- EXP. 12/31/93

DATE	APRIL 30, 1992
REVISED	
DETAIL	B-9-2 SHEET 2 OF 2

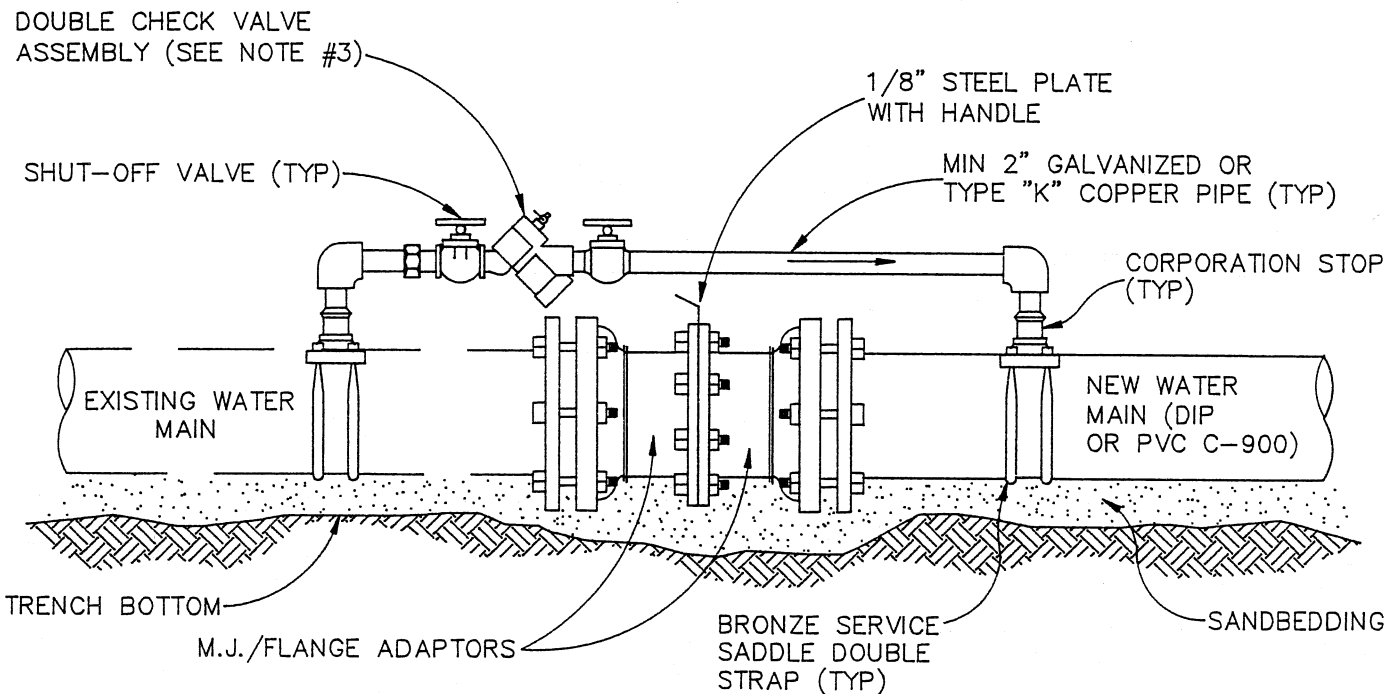

NOTES:

1. THE CONTRACTOR SHALL NOT OPERATE AGENCY VALVES. 48 HOURS NOTICE IS REQUIRED FOR OPERATION BY AGENCY.
2. UPON ACCEPTANCE OF THE NEW WATER SYSTEM, THE CONTRACTOR SHALL REMOVE THE 2" BYPASS AND THE STEEL PLATE THEN SHUT-OFF COCKS AND INSTALL PLUGS IN EACH CORPORATION STOP.
3. THE DOUBLE CHECK VALVE ASSEMBLY SHALL BE FEBCO 805Y OR APPROVED EQUAL.
4. SHUT-OFF BOTH VALVES ON THE DOUBLE CHECK VALVE ASSEMBLY DURING PRESSURE TESTING AND DISINFECTION OF THE NEW WATER MAIN.
5. SIZE OF BYPASS MAY BE INCREASED AS DIRECTED BY CITY ENGINEER.

BYPASS CONNECTION TO NEW MAINS

CITY OF HOLLISTER  
STANDARD PLANS

APPROVED:

*Max H. Bridges*  
MAX H. BRIDGES, R.C.E. 24152- EXP. 12/31/93

DATE	APRIL 30, 1992
REVISED	
DETAIL	B-10
SHEET 1 OF 1	

THRUST BLOCK AREA REQUIRED - SQUARE FEET

TYPE OF FITTING	90° BEND	45° BEND	22.5° BEND	11.25° BEND	TEE	TEE W/ PLUG	CROSS W/ PLUG	CROSS W/ PLUGS
TYPICAL INSTALLATION								
SIZE OF PIPE	6"	6	4	2	1	6	6	6
	8"	10	6	3	2	10	10	10
	10"	15	8	4	2	16	15	15
	12"	21	11	6	3	22	21	21

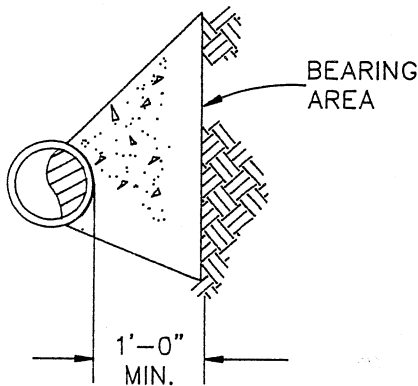

SECTION

NOTES

1. JOINTS, FITTINGS AND FACES OF PLUGS TO BE KEPT CLEAR OF CONCRETE.
2. BLOCKS MUST BE POURED AGAINST UNDISTURBED SOIL.
3. THRUST BLOCKS SHALL BE CONSTRUCTED OF CLASS 420-C-2000 OR STRONGER P.C.C.
4. STIRRUPS TO BE #4 REBAR EMBEDDED IN THRUST BLOCK TO A DEPTH EQUAL TO 3/4 OF PIPE OUTSIDE DIAMETER. STIRRUP HOOKS TO BE SHAPED 90° BEND WITH LENGTH EQUIVALENT TO 1/2 PIPE O.D.
5. THRUST BLOCK AREA IS BASED ON TEST PRESSURE OF 150 PSI AND A HORIZONTAL SOIL BEARING STRENGTH OF 1500 PSI.
6. EXPOSED STIRRUPS SHALL BE PAINTED WITH TWO COATS OF KOPPERS 505, TNEMEC 46-450', AMERON OR EQUAL, 15 MILS EACH COAT.

THRUST BLOCK DETAIL

CITY OF HOLLISTER  
STANDARD PLANS

APPROVED:

MAX H. BRIDGES R.C.E. 24152- EXP. 12/31/93

DATE

APRIL 30, 1992

REVISED

DETAIL

B-11

SHEET 1 OF 1

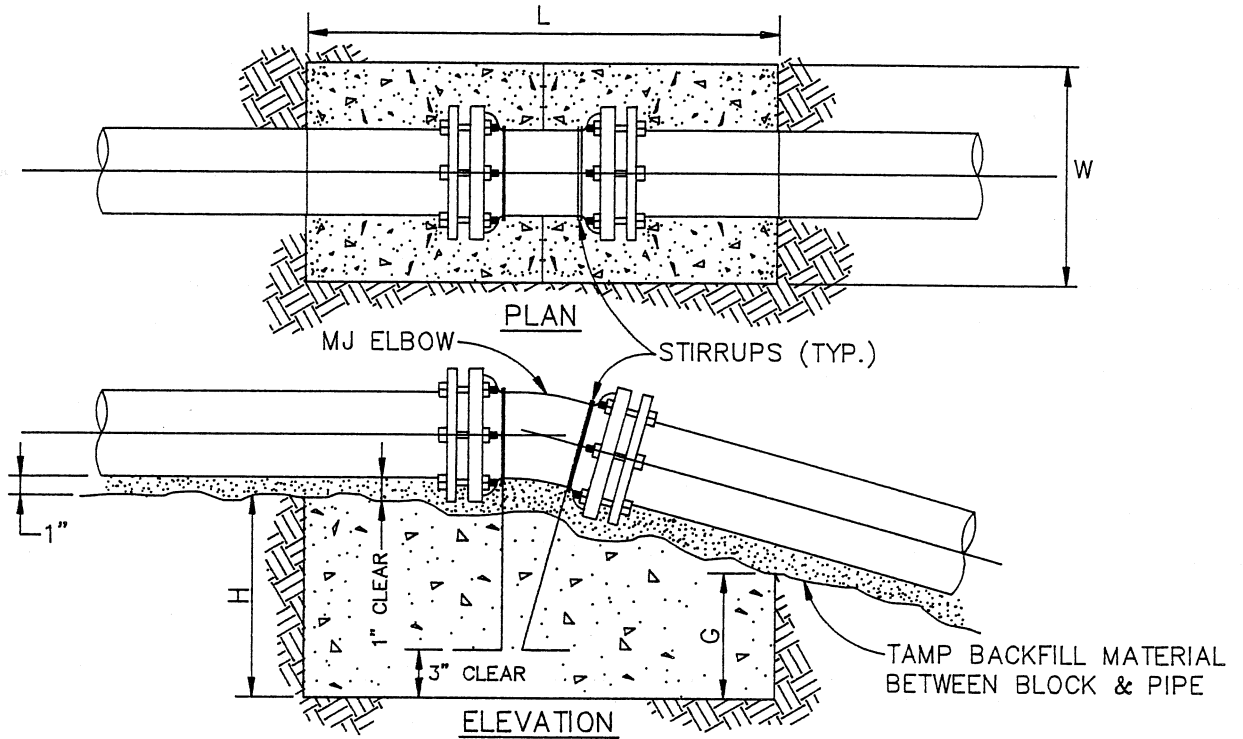

### THRUST BLOCK DIMENSION — UPWARD THRUST

PIPE SIZE	11 1/4° BEND					22 1/2° BEND					45° BEND				
	L	W	H	G	BAR	L	W	H	G	BAR	L	W	H	G	BAR
6"	3.0	2.0	2.0	1.0	4	4.0	2.0	3.0	1.0	4	5.0	3.0	3.0	1.0	4
8"	3.5	2.5	2.0	1.0	4	4.5	3.0	3.0	1.0	4	6.0	3.0	4.0	1.5	4
10"	4.0	3.0	2.5	1.0	4	5.0	4.0	3.5	1.5	5	6.0	4.0	4.5	1.5	5
12"	4.0	3.5	3.0	1.5	4	5.0	4.0	3.5	2.0	5	7.0	4.0	5.0	2.5	5

**NOTES:**

1. DIMENSIONS L, W, H, AND G ARE IN FEET.
2. THRUST BLOCK DIMENSIONS BASED ON 150 PSI TEST PRESSURE AND CONCRETE OF 150 PCF UNIT WEIGHT.
3. EXPOSED STIRRUPS TO BE PAINTEND WITH TWO COATS OF KOPPERS 505, TNE MEC 46-450, AMERON OR EQUAL TO 15 MILS EACH COAT.
4. THRUST BLOCKS SHALL BE CLASS 420-C-2000 P.C.C.
5. FLANGES, NUTS & BOLTS SHALL BE CLEAR OF CONCRETE.
6. ANY ALTERNATIVES TO THE PREFERRED M.J. FITTING & THRUST BLOCK SHALL REQUIRE ENGINEERING DEPARTMENT REVIEW & APPROVAL.
7. STIRRUPS TO BE #4 REBAR.

## UPWARD THRUST BLOCK DETAIL

CITY OF HOLLISTER  
STANDARD PLANS

APPROVED:

*Max H. Bridges*

MAX H. BRIDGES R.C.E. 24152 - EXP. 12/31/93

DATE

APRIL 30, 1992

REVISED

DETAIL

B-12

SHEET 1 OF 1

NEW SEWER MAIN

NEW WATER MAIN

TRENCH SECTION FOR PERPENDICULAR CONSTRUCTION

12' SOLVENT-WELD JOINTED PIPE  
20' FOR ALL OTHERS

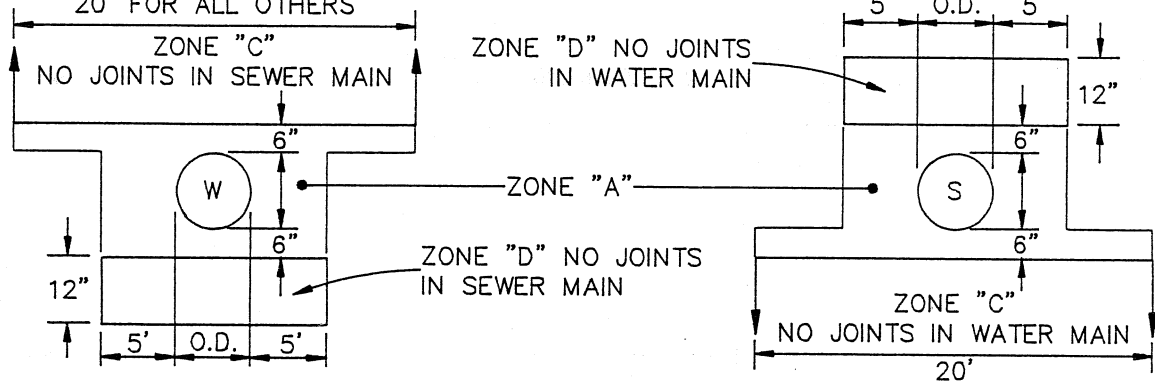

TRENCH SECTION FOR PARALLEL CONSTRUCTION

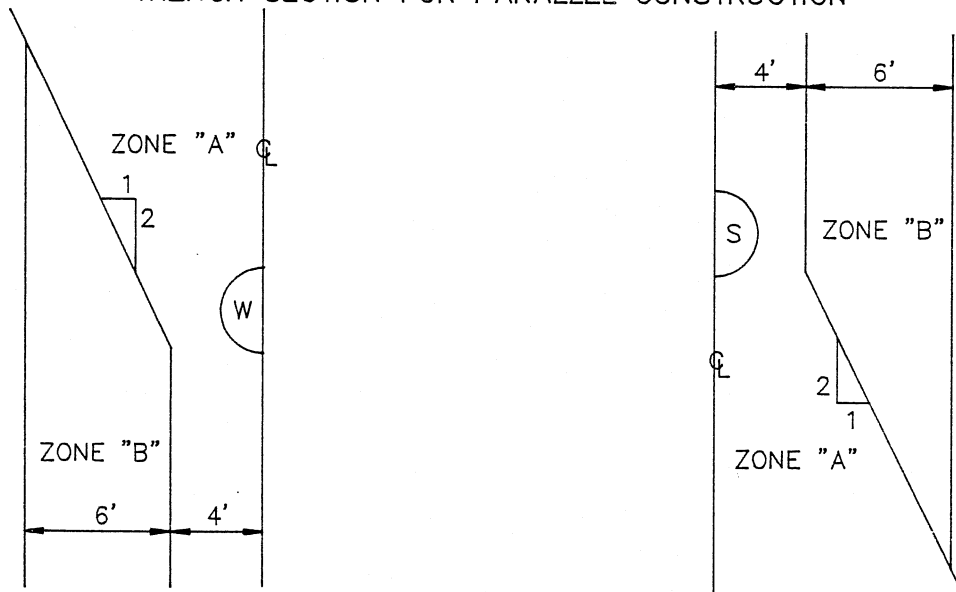

NOTES:

1. PARALLEL CONSTRUCTION WILL BE ALLOWED ONLY WHEN 10' HORIZONTAL SEPARATION BETWEEN SEWER AND WATER LINES CANNOT BE MAINTAINED, AND ONLY AS APPROVED BY THE CITY ENGINEER.
2. ZONE "A" - CONSTRUCTION PROHIBITED.
3. ZONE "B" - SEWER MUST BE SOLVENT WELD JOINT COMPOSITE PIPE, OR WATER MUST BE AWWA C-900, CLASS 200, OR D.I.P. CLASS 50.
4. ZONE "C" & "D" - SEWER & WATER PIPE TO MEET CITY STANDARD REQUIREMENTS.
5. ALL DIMENSIONS ARE MINIMUM AND APPLY ONLY TO GRAVITY SEWER MAINS. THE ZONES ILLUSTRATED ARE NOT APPLICABLE WITH SEWER PRESSURE MAINS.
6. REQUIREMENTS APPLY TO BOTH SANITARY SEWER AND STORM SEWER.

**WATER/SEWER SEPARATION REQUIREMENTS**

CITY OF HOLLISTER

STANDARD PLANS

APPROVED:

*Max H. Bridges*

MAX H. BRIDGES R.C.E. 24152- EXP. 12/31/93

DATE

APRIL 30, 1992

REVISED

DETAIL

B-13

SHEET 1 OF 1

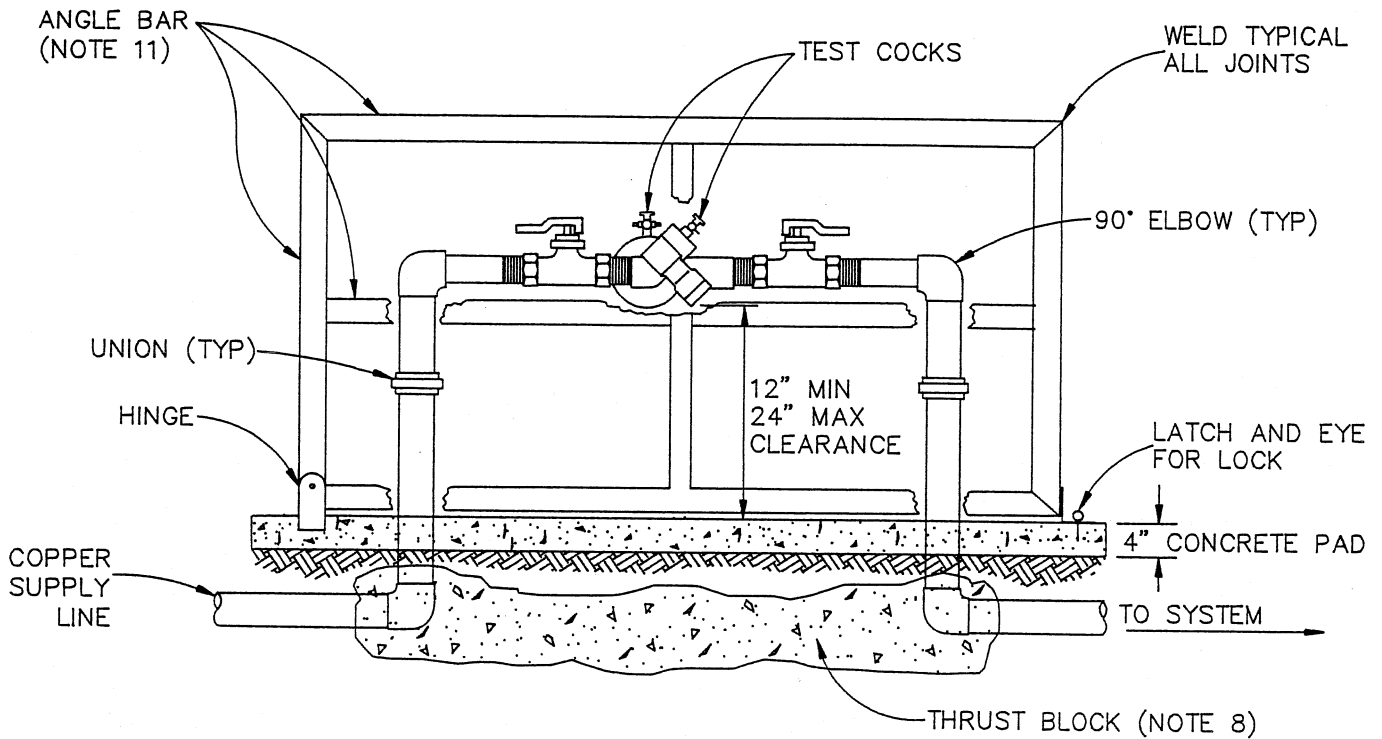

NOTES:

1. REDUCE PRESSURE PRINCIPLE BACKFLOW PREVENTER ASSEMBLIES SHALL BE FEBCO 825Y OR APPROVED EQUAL. THE ENTIRE ASSEMBLY SHALL BE PROVIDED AS A UNIT, INCLUDING BALL VALVES & TEST COCKS.
2. NO CONNECTIONS OR TEES WILL BE ALLOWED BETWEEN WATER METER & REDUCE PRESSURE PRINCIPLE BACKFLOW PREVENTER.
3. ALL TUBING SHALL BE TYPE "K" COPPER.
4. INSTALLATIONS USING THREADED OR SOLDERED FITTINGS SHALL INCLUDE ONE THREE PART UNION ON EACH SIDE OF THE ASSEMBLY, SOLDER SHALL BE LEAD FREE.
5. DEVICE MUST BE ACCESSIBLE FOR TESTING & MAINTANCE.
6. ASSEMBLY SHALL CONFORM TO THE LATEST REVISION OF THE CALIFORNIA DEPARTMENT OF HEALTH SERVICES APPROVED LIST FOR CROSS-CONNECTION.
7. A TEST OF THE REDUCED PRESSURE PRINCIPLE BACKFLOW PREVENTER BY A CERTIFIED INDIVIDUAL SHALL BE REQUIRED.
8. THRUST BLOCK SHALL BE CLASS 420-C-2000 P.C.C.
9. CONCRETE PAD TO BE 520-C-2500 P.C.C. TOP OF PAD TO BE LEVEL AND SET 1" MINIMUM ABOVE EXISTING SOIL LEVEL.
10. PAINT CAGE WITH 2 COATS OF RUSTOLEUM MED. GREEN.
11. CAGE DIMENSIONS 24" WIDE x 36" HIGH x 42" LONG. PROVIDE HINGE AS SHOWN WITH LATCH FOR PAD LOCK, SUPPLY 3 KEYS TO CITY.
12. THE CAGE SHALL BE HEAVY EXPANDED FLAT METAL WELDED TO 1 1/2" X 1 1/2" X 1/8" ANGLE BAR.

REDUCE PRESSURE PRINCIPLE BACKFLOW PREVENTER  
(2"Ø & SMALLER)

CITY OF HOLLISTER  
STANDARD PLANS

APPROVED:

*Max H. Bridges*  
MAX H. BRIDGES R.C.E. 24152-EXP. 12/31/93

DATE

APRIL 30, 1992

REVISED

DETAIL

B-14

SHEET 1 OF 1

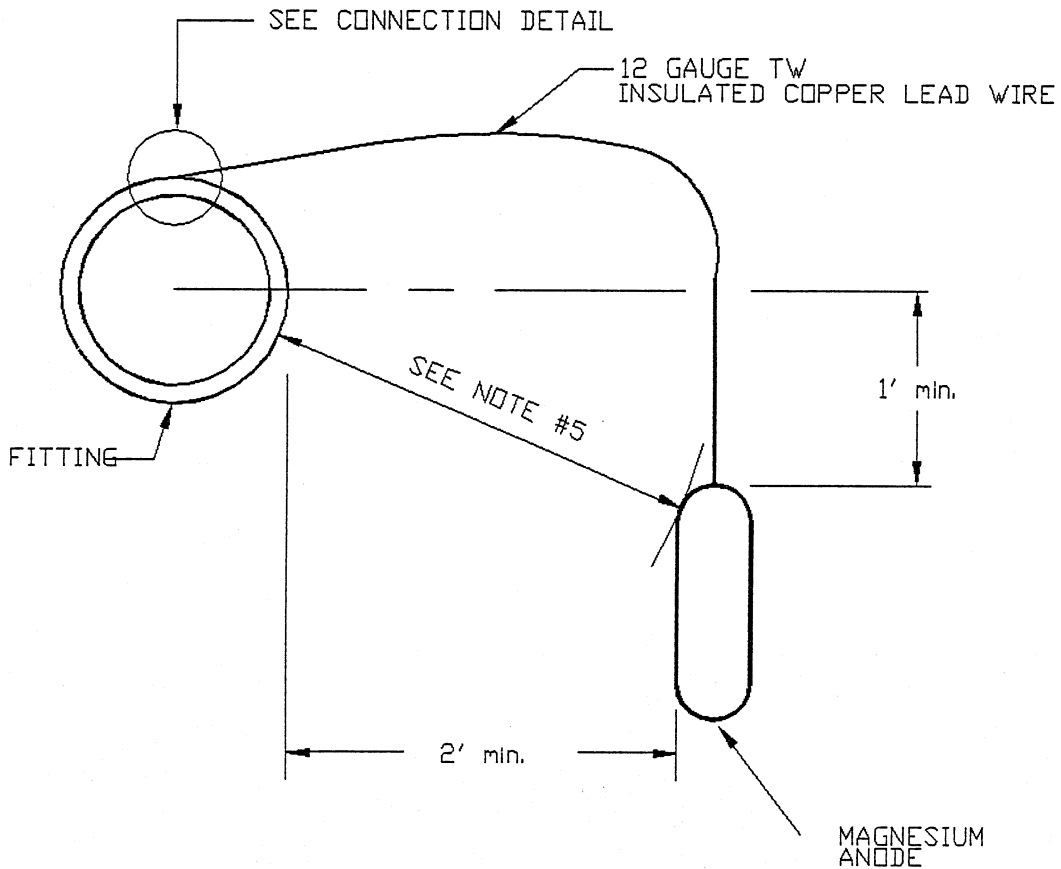

NOTES:

1. SEE STANDARD PLAN B-15-2 FOR CONNECTION DETAIL AND FOR ANODE DETAIL.
2. MIX EPOXY PUTTY (EPOXY BOND PLUMBER SEAL) AS DIRECTED AND APPLY FIRMLY TO PROVIDE A WATER TIGHT SEAL AT LEAST 1/4" THICK OVER CONNECTION WELD, BARE WIRE AND BARE PIPE.
3. OVERLAP CONNECTION COATING AND WIRE INSULATION BY 1/2".
4. ANODE IS SHOWN INSTALLED VERTICALLY. IT MAY BE INSTALLED HORIZONTALLY IF MORE CONVENIENT.
5. 3 FOOT MINIMUM RADIAL CLEARANCE IS REQUIRED BETWEEN THE ANODE AND THE FITTING.
6. INSULATED COPPER LEAD WIRE SHALL BE CONTINUOUS WITH NO SPLICES.

CORROSION PROTECTION WITH Mg ANODE

CITY OF HOLLISTER  
STANDARD PLANS

APPROVED:

*Max H. Bridges*  
MAX H. BRIDGES P.E. 24152- EXP. 12/31/93

DATE

5-13-92

REVISED

DETAIL

B-15-1

SHEET 1 OF 2



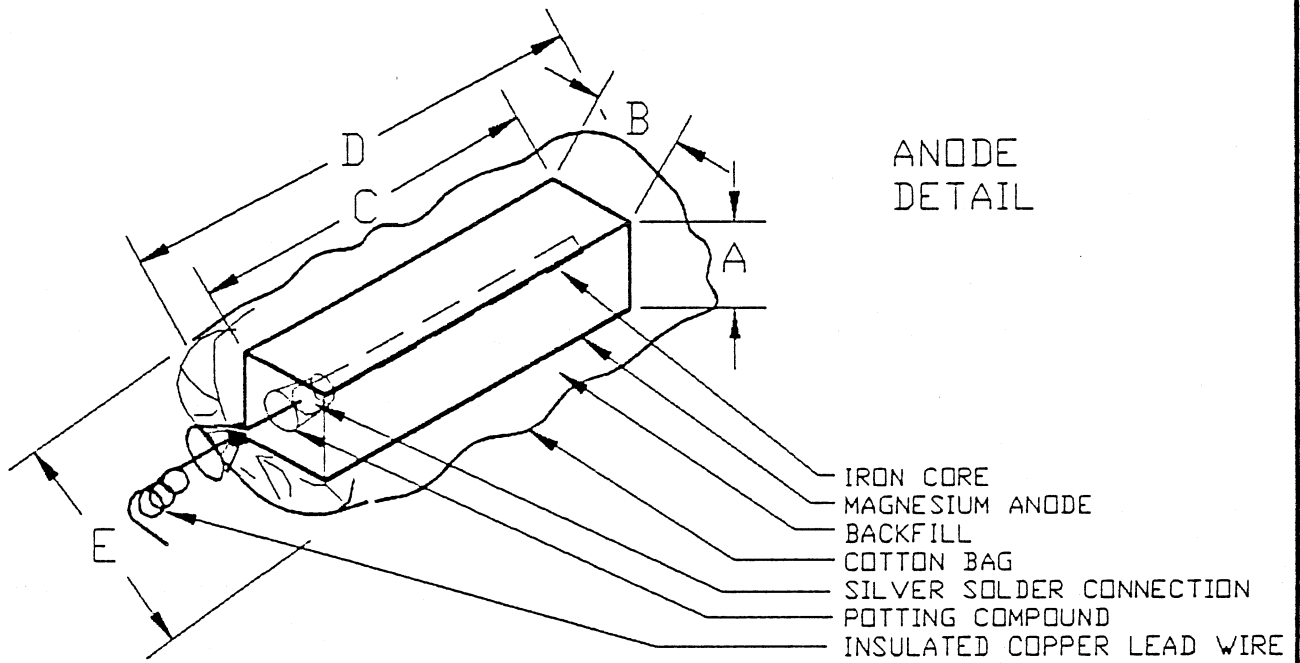

FITTING SIZE NOMINAL DIA.	NOMINAL DIMENSION					MAGNESIUM WEIGHT IN POUNDS	TOTAL WEIGHT IN POUNDS
	A	B	C	D	E		
6' - 8'	3'	3'	13.5'	15.5'	6'	9 LBS.	23 LBS.
10' - 12'	4'	4'	17'	19'	6.5'	17 LBS.	42 LBS.
14' - 24'	5'	5'	21'	23'	8'	32 LBS.	70 LBS.

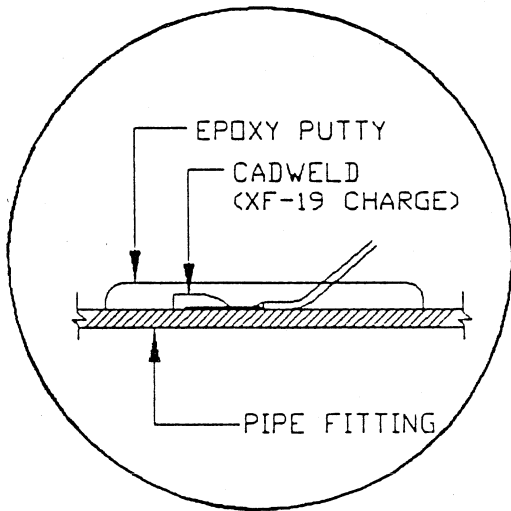

SEE STANDARD PLAND B-15-1 FOR CONNECTION NOTES.

## ANODE AND CONNECTION DETAILS

CITY OF HOLLISTER

STANDARD PLANS

APPROVED:

MAX H. BRIDGES R.C.E. 24152- EXP. 12/31/93

DATE

5-13-92

REVISED

DETAIL

B-15-2

SHEET 2 OF 2

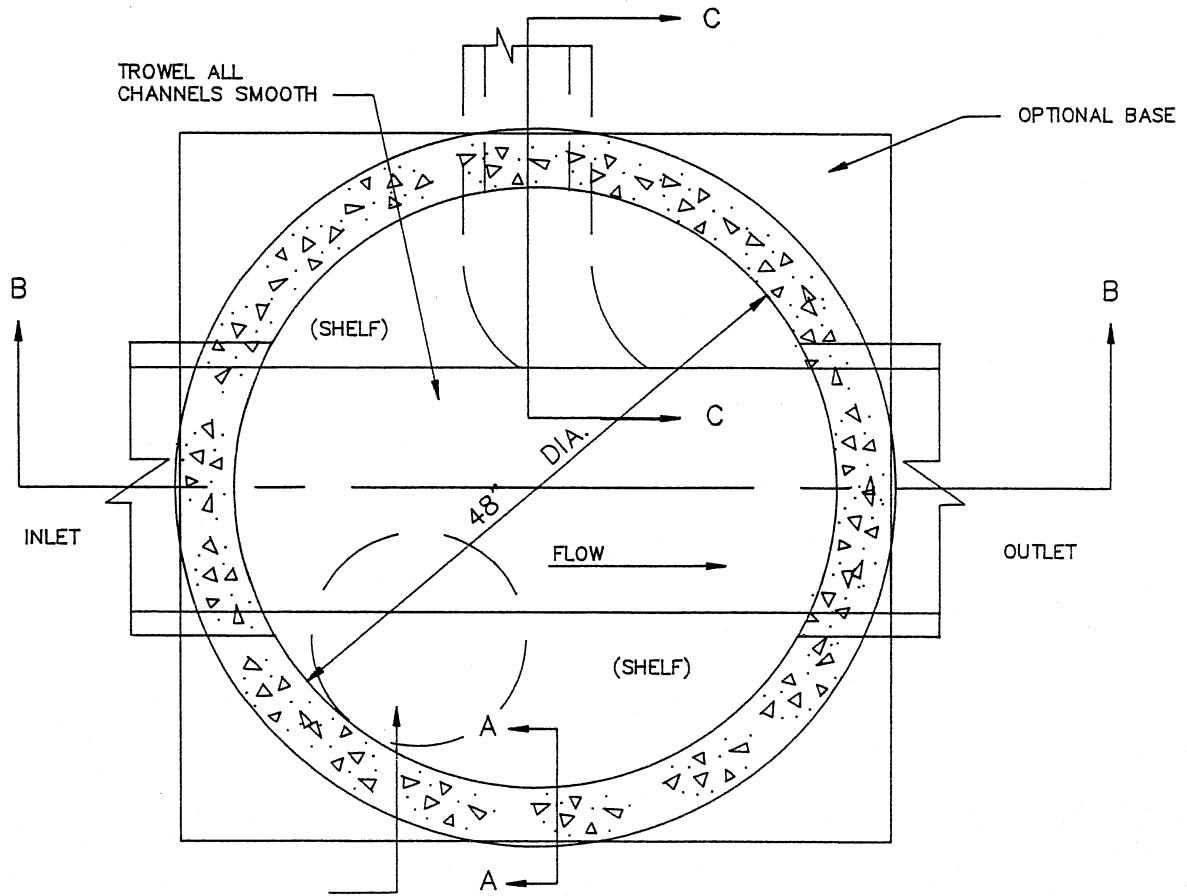

PLAN VIEW

ROTATE MH SECTION TO PROVIDE STEPS OVER SHELF, WHEN INLET PIPE IS 18" OR LARGER.

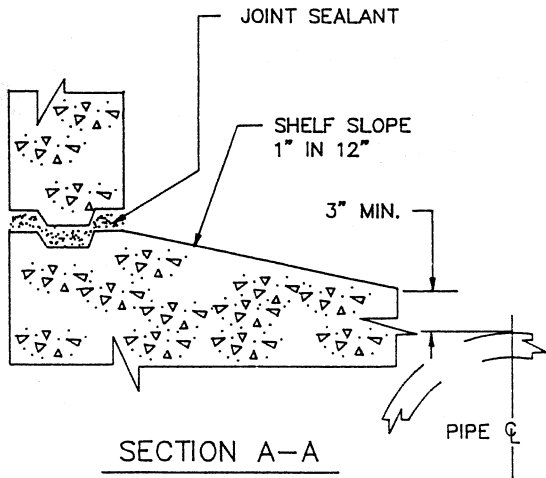

SECTION A-A

SEE DETAIL C-1-2 FOR STANDARD MANHOLE SECTIONS  
 SEE DETAIL C-1-3 FOR DROP MANHOLE SECTION  
 SEE DETAIL C-2 FOR CONSTRUCTION AND MATERIAL NOTES

# TYPE I ECCENTRIC MANHOLE ( 6" TO 33" PIPE )

CITY OF HOLLISTER  
 STANDARD PLANS

APPROVED: *Max H. ...*

DATE	APRIL 30, 1992
REVISED	
DETAIL	C-1-1

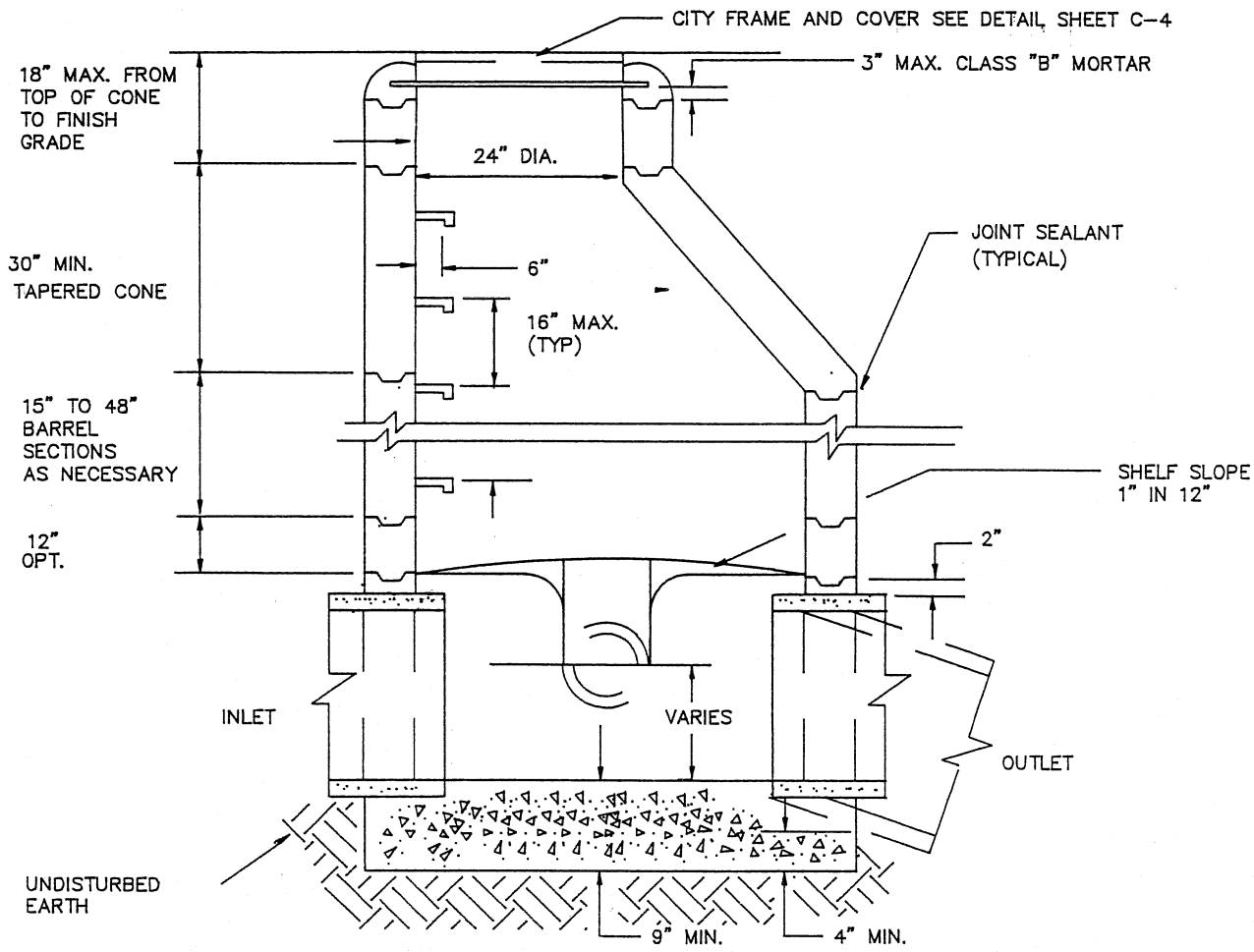

SECTION B-B

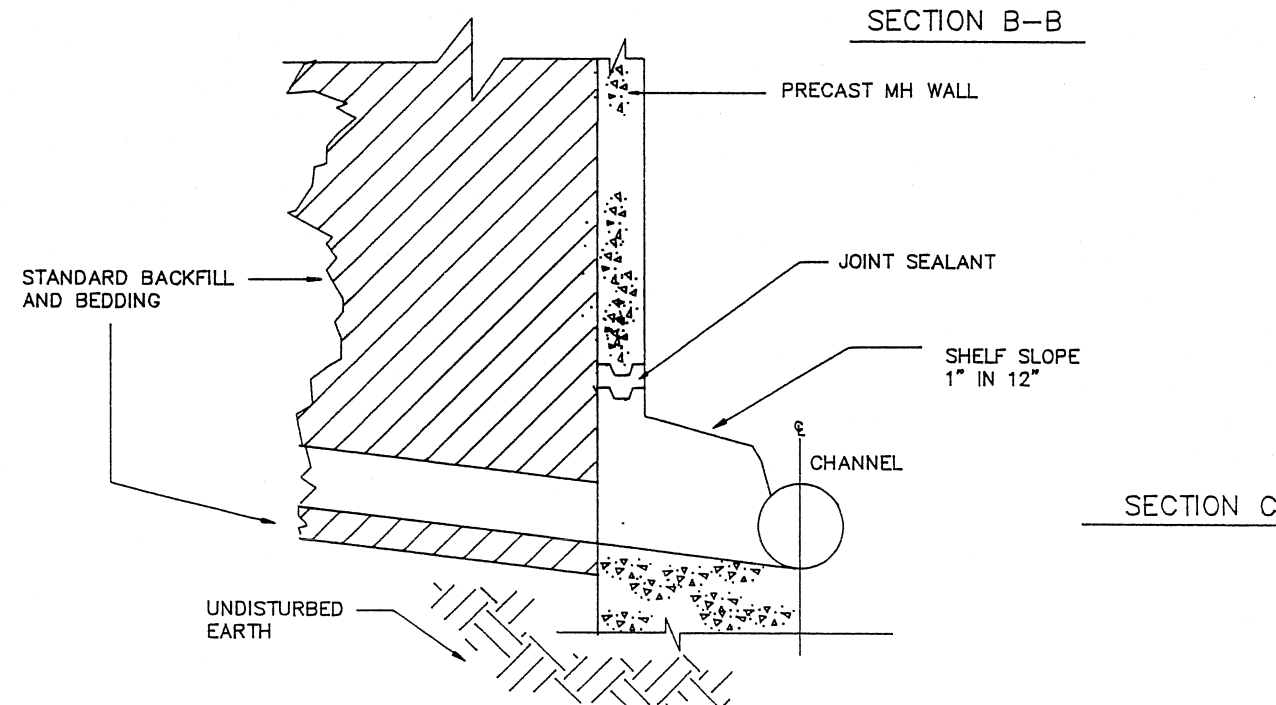

SECTION C-C

TYPE I ECCENTRIC MANHOLE (6" TO 33")

CITY OF HOLLISTER  
STANDARD PLANS

APPROVED: *Max H. Bridges*  
MAX. H. BRIDGES, P.E. 24152 EXP. 12/31/07

DATE	APRIL 30, 1992
REVISED	
DETAIL	C-1-2 SHEET 2 OF 3

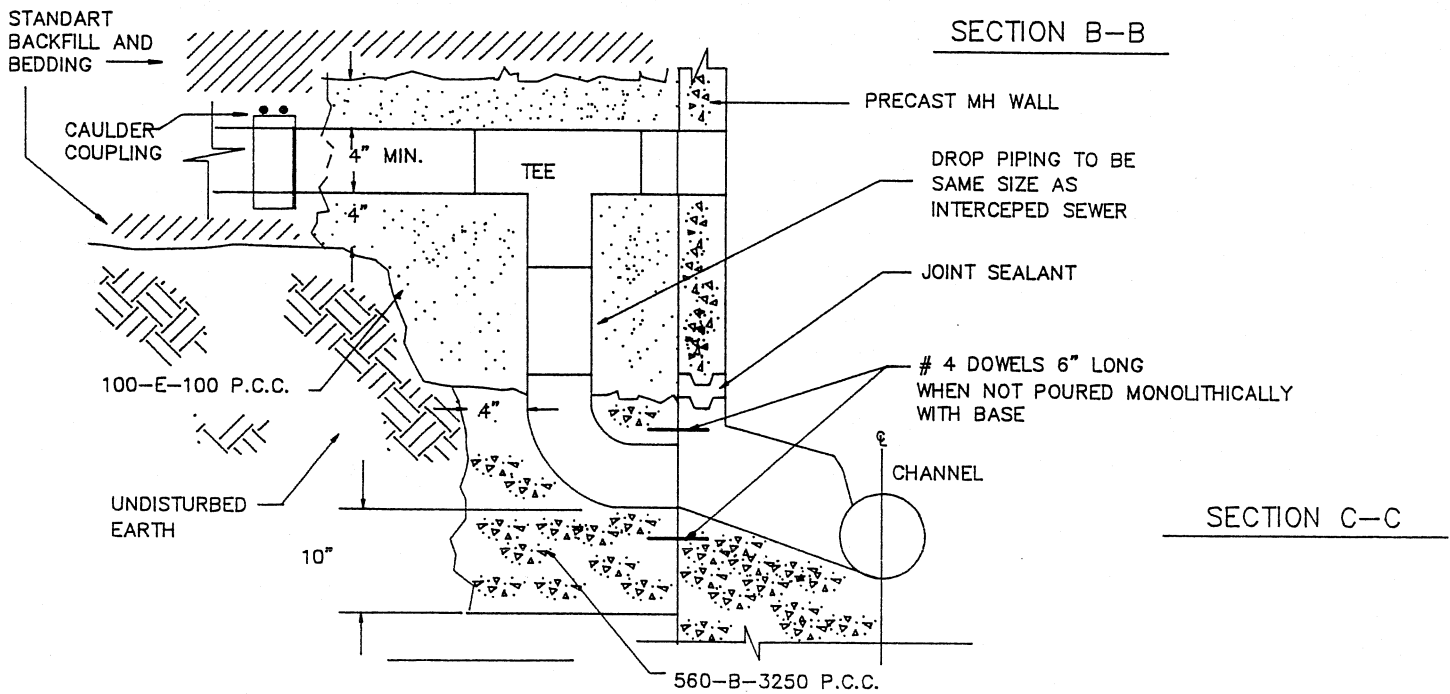
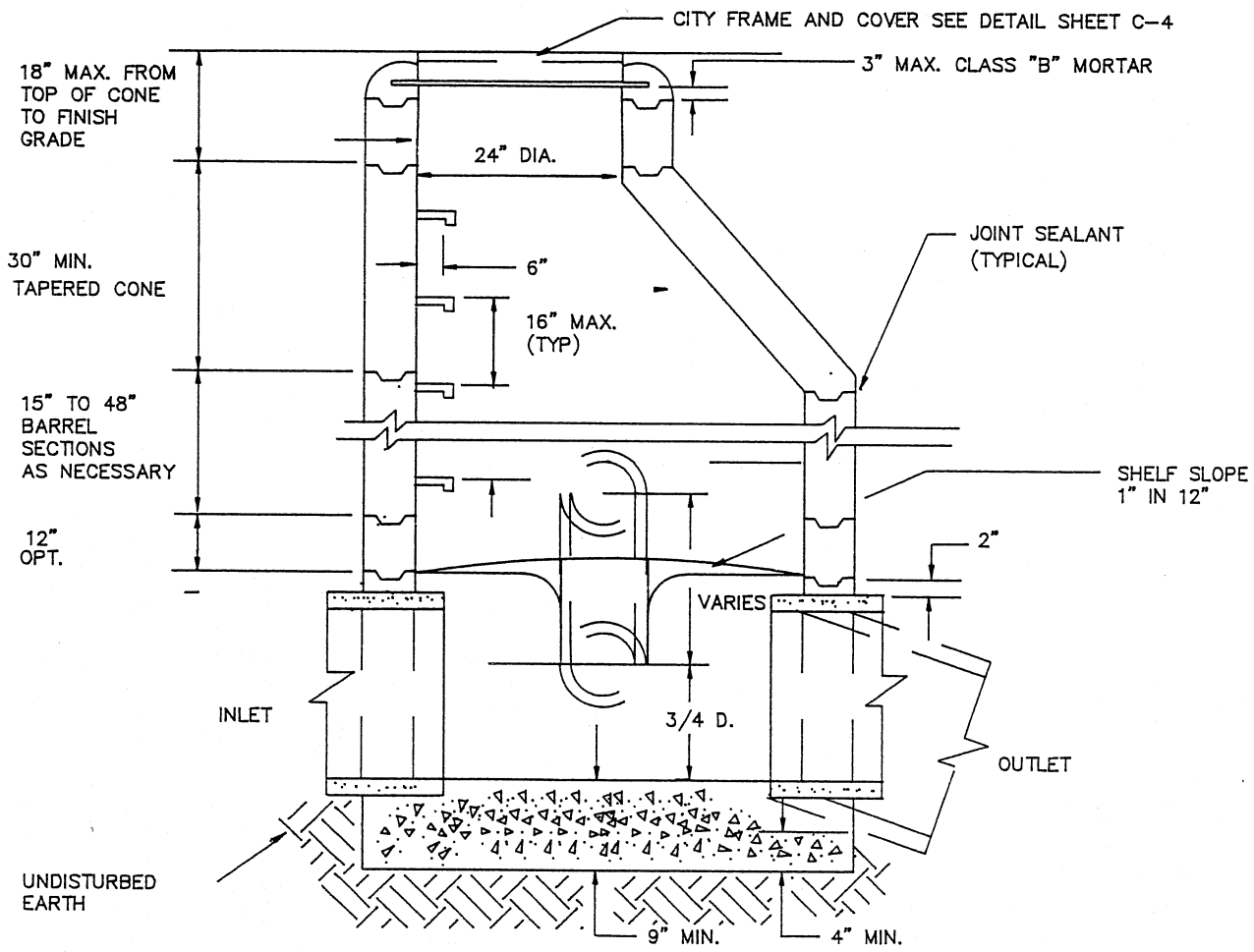

TYPE i ECCENTRIC DROP MANHOLE (6" - 33")

CITY OF HOLLISTER  
STANDARD PLANS

APPROVED: *Max H. Bridges*

DATE	APRIL 30, 1992
REVISED	
DETAIL	C-1-3 SHEET 1 OF 1

MAX H. BRIDGES, P.C.E. 24152 EXP. 12/31/03

NOTES:

1. EXCEPT AS NOTED HEREON, THE PRECAST UNITS SHALL BE MANUFACTURED AND TESTED IN ACCORDANCE WITH ASTM C 478. AS AN ALTERNATE CURING METHOD. THE UNITS MAY BE CURED USING SATURATED STEAM FOR A MINIMUM OF 12 HOURS, FOLLOWED BY 6 DAYS WATER CURING OR MEMBRANE CURING. IF THE UNITS ARE CURED BY THE ALTERNATE METHOD, THEY SHALL NOT BE SHIPPED PRIOR TO 8 DAYS AFTER CASTING NOR UNTIL THE CONCRETE HAS ATTAINED A STRENGTH OF 3500 P.S.I.

2. MANHOLE STEPS SHALL BE MODEL PS2-PF AS MANUFACTURED BY M.A. IND. OR APPROVED EQUAL. THE MANHOLE STEPS SHALL BE UNIFORMLY SPACED AT A MAXIMUM OF 16" WITH THE TOP STEP PLACED NO MORE THAN 18" UNDER THE MANHOLE FRAME. THE LOWEST STEP SHALL BE PLACED NOT LESS THAN 8" NOR MORE THAN 24" ABOVE THE SHELF. THE TOP STEP IF PLACED IN THE 24" DIAMETER SECTION SHALL PROJECT 5" INSIDE THE MANHOLE AND ALL OTHER 6".

3. RISER SECTIONS AND CONES MAY BE REINFORCED OR UNREINFORCED. REINFORCED SECTIONS AND CONES SHALL BE REINFORCED IN ACCORDANCE WITH ASTM C 478 AND SHALL HAVE A MINIMUM WALL THICKNESS OF 4". UNREINFORCED RISER SECTIONS AND CONES SHALL HAVE A MINIMUM WALL THICKNESS OF 6".

4. JOINTS SHALL BE TONGUE AND GROVE AND SHALL CONFORM WITH ASTM C 478 SECTION 14.

5. AN IMPRESSION RING SHALL BE USED PRIOR TO INSTALLING THE FIRST RISER SECTION. PRECAST UNITS SHALL BE ASSEMBLED USING PREFORMED RAM-NEK JOINT SEALING COMPOUND OR CLASS "B" MORTAR.

6. INSTALL MANHOLE WATER STOP GASKET AND CLAMP ASSEMBLY ON ALL SANITARY SEWER PIPES.

CONSTRUCTION & MATERIAL NOTES

CITY OF HOLLISTER

STANDARD PLANS

APPROVED:

*Michael S. Bush*

DATE

APRIL 30, 1992

REVISED

DETAIL

C-2

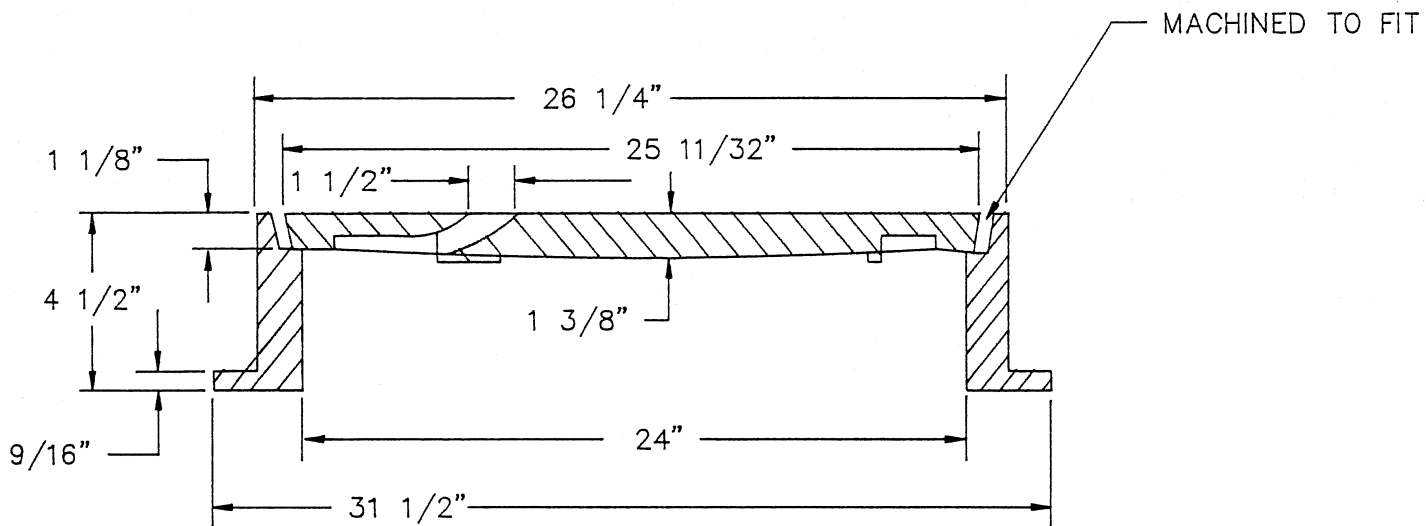
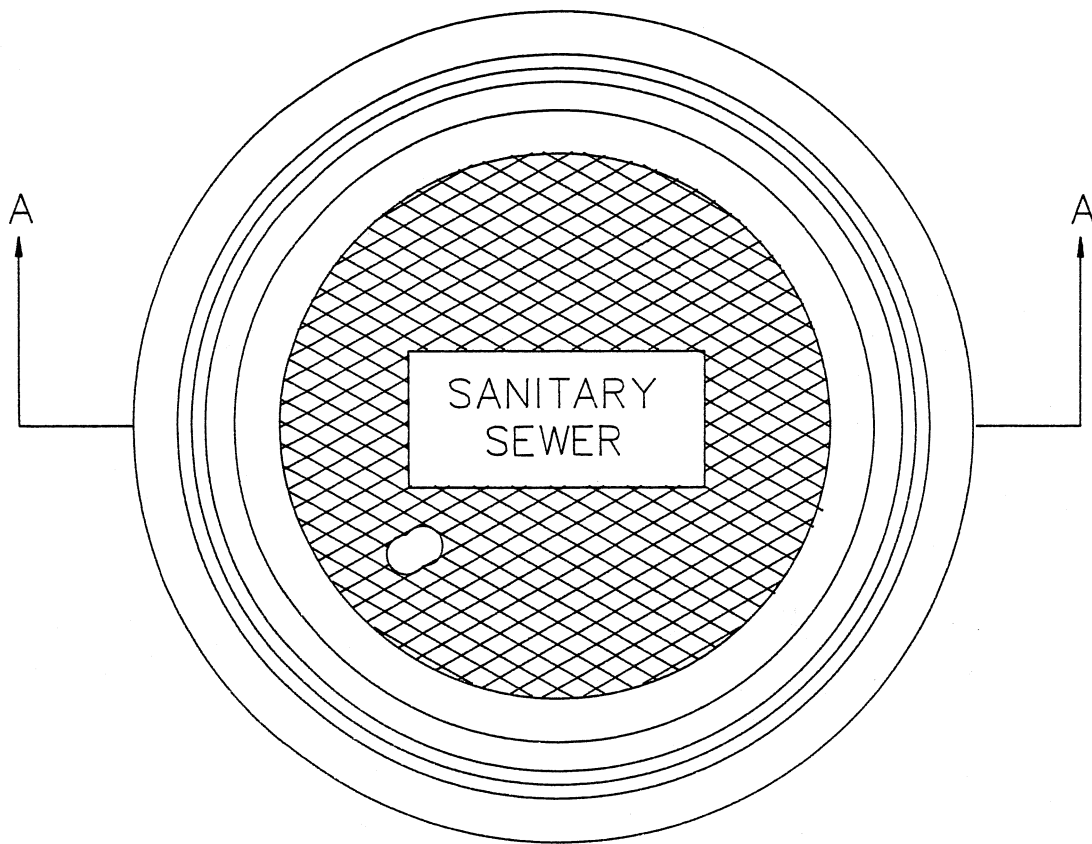

SECTION A-A

NOTES:

1. FRAME AND COVER SHALL BE PHEONIX IRON WORKS # P-1090 OR APPROVED EQUAL. DIPPED IN ASPHALT PAINT.
2. SPECIFY "SANITARY SEWER" OR " STORM SEWER" AS APPROPRIATE.

MANHOLE FRAME AND COVER

CITY OF HOLLISTER

STANDARD PLANS

APPROVED:

*Max H. Bridges*

MAX H. BRIDGES R.C.E. 24152- EXP. 12/31/93

DATE

*APRIL 30, 1992*

REVISED

DETAIL

*C-3* SHEET 1 OF 1

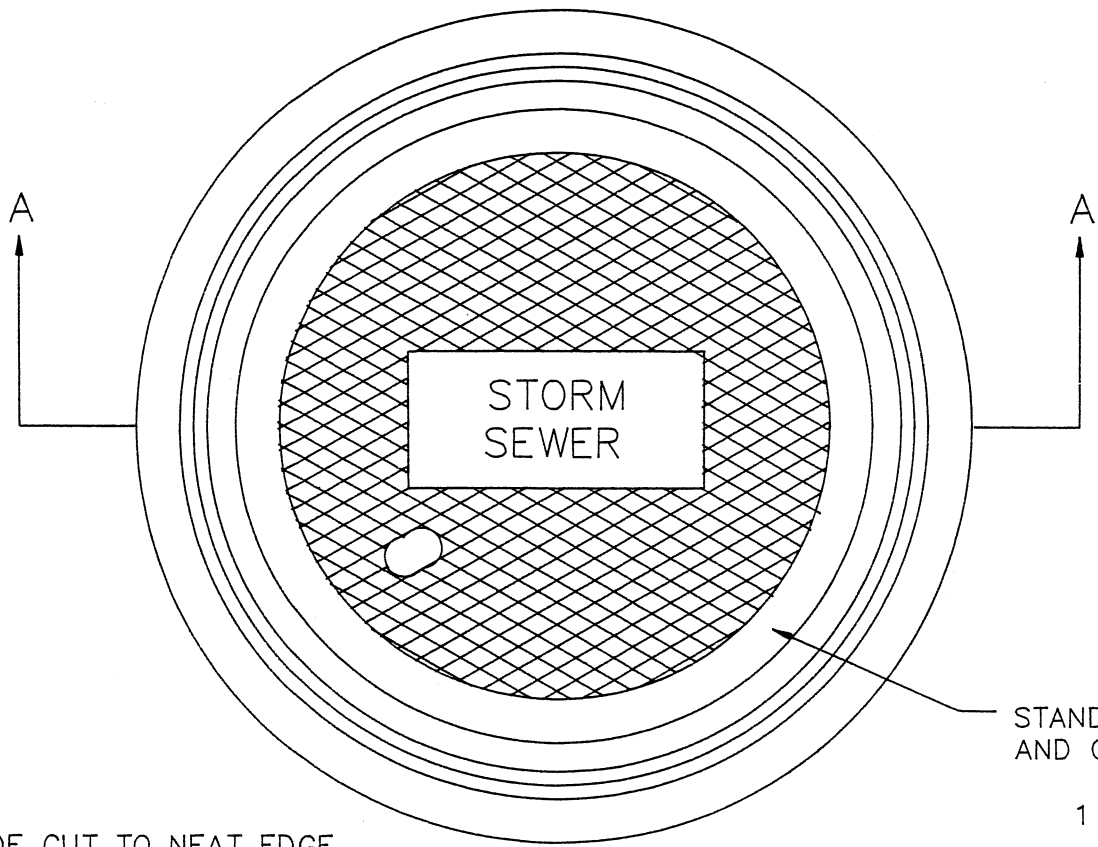

STANDARD FRAME AND COVER.

SPADE CUT TO NEAT EDGE

MIN. 1 1/2" THICK A.C. PAVEMENT  
TACK ALL SURFACES TO BE PAVED ON  
OR AGAINST.

1 1/2"

10" MIN.

FRAME TO BE SET IN FULL  
CLASS "B" MORTAR JOINT

12" MIN.

PRECAST ADJUSTING RINGS

CLASS 520-C-2500 P.C.C. COLLAR

SECTION A-A

FRAME AND COVER ADJUSTMENT IN PAVEMENT

CITY OF HOLLISTER

STANDARD PLANS

APPROVED: *[Signature]*

MAX H. BRIDGES R.C.E. 24152 - EXP. 12/31/93

DATE *APRIL 30, 1992*

REVISED

DETAIL **C-4** SHEET 1 OF 1

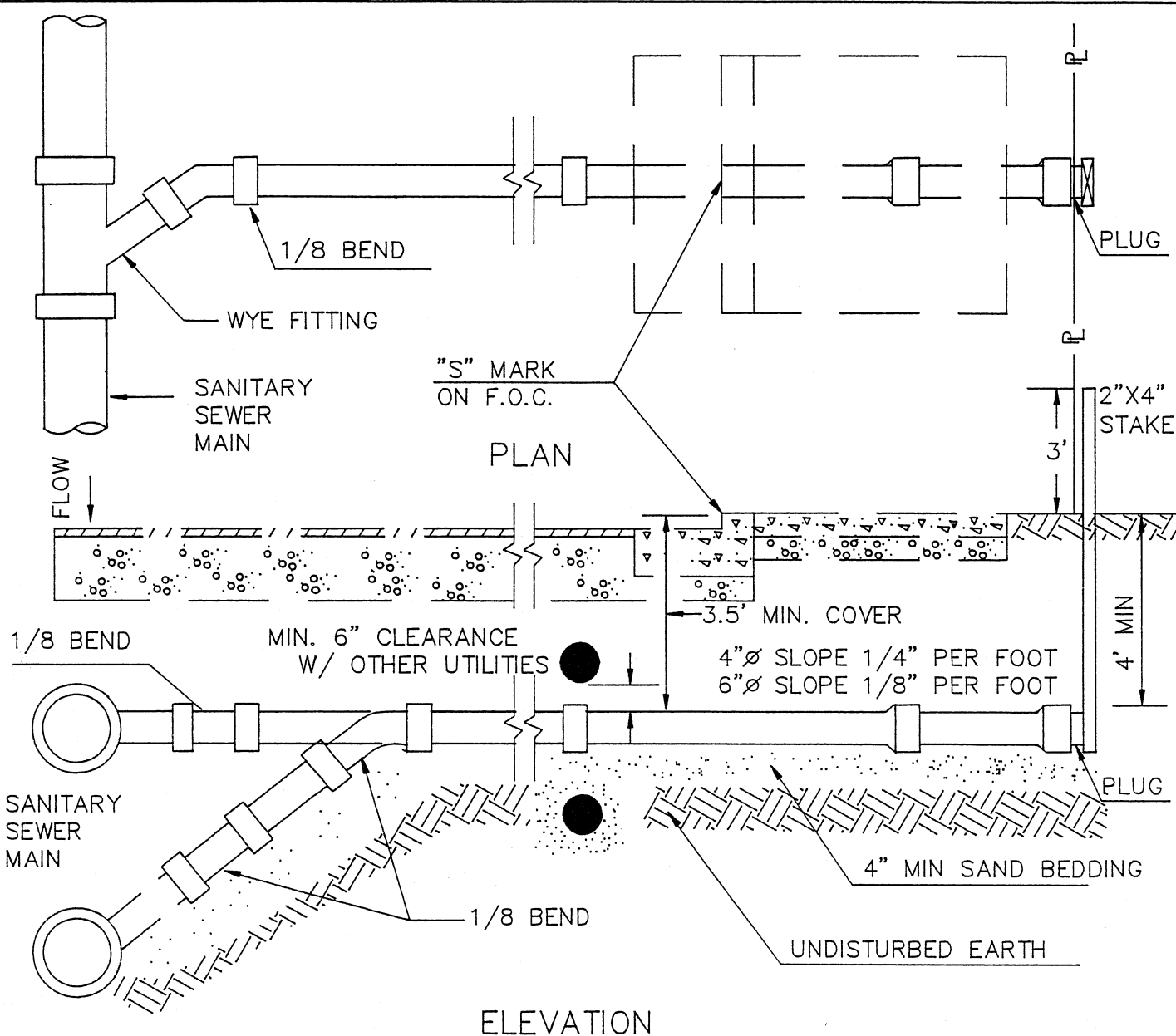

NOTES:

1. SEWER LATERALS SHALL BE ABS (SDR 23.5) OR PVC (SHC. 40) PIPE.
2. STAMP OR CHISEL AN "S" ON THE FACE OF CURB AT LATERAL LOCATION.
3. A PRESSURE TREATED DOUGLAS FIR STAKE SHALL BE INSTALLED AT EACH LATERAL TERMINUS. ALL STAKES SHALL BE PAINTED WHITE.
4. ALL SAND BACKFILL SHALL BE COMPACTED TO 90% RELATIVE COMPACTION.
5. ALL SEWER LATERALS SHALL PASS A LOW PRESSURE AIR TEST.

## SEWER LATERAL

CITY OF HOLLISTER

STANDARD PLANS

APPROVED: *Max H. Bridges*  
 MAX H. BRIDGES R.C.E. 24152 - EXP. 12/31/93

DATE	APRIL 30, 1992
REVISED	
DETAIL	C-5

Sheet 1 of 1



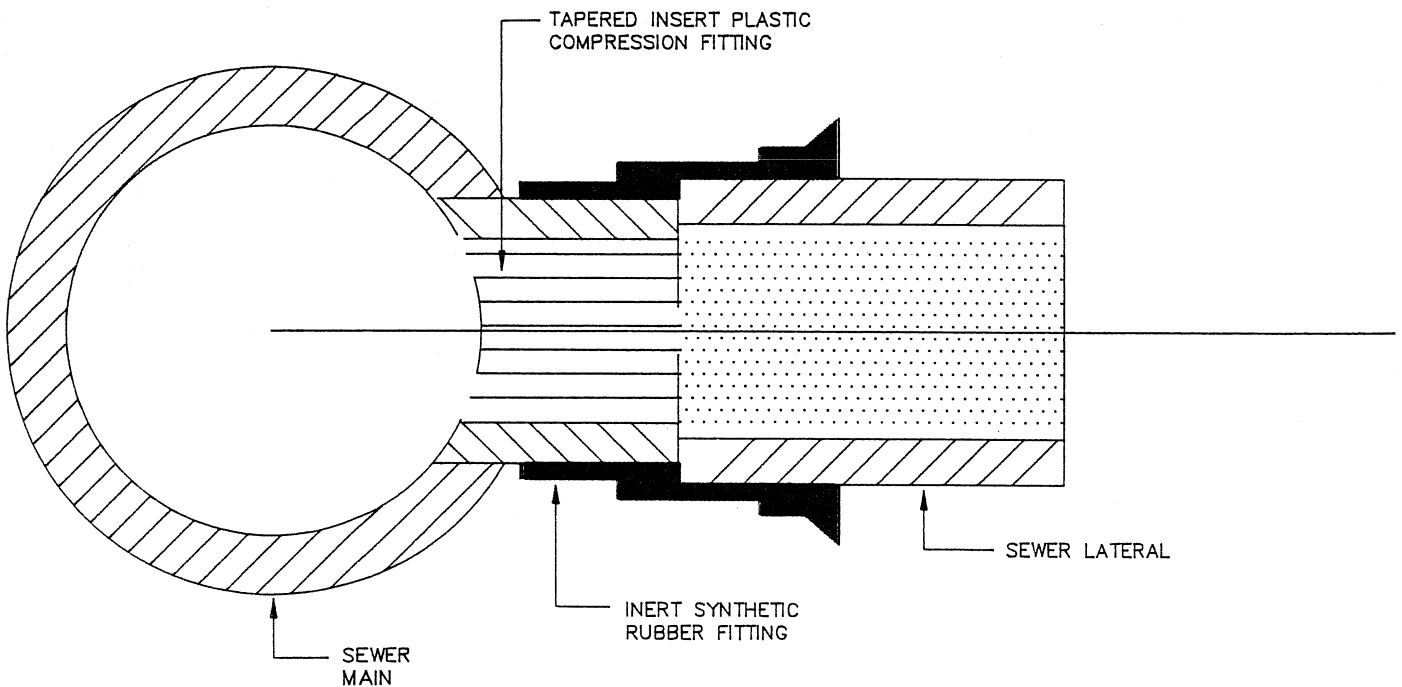
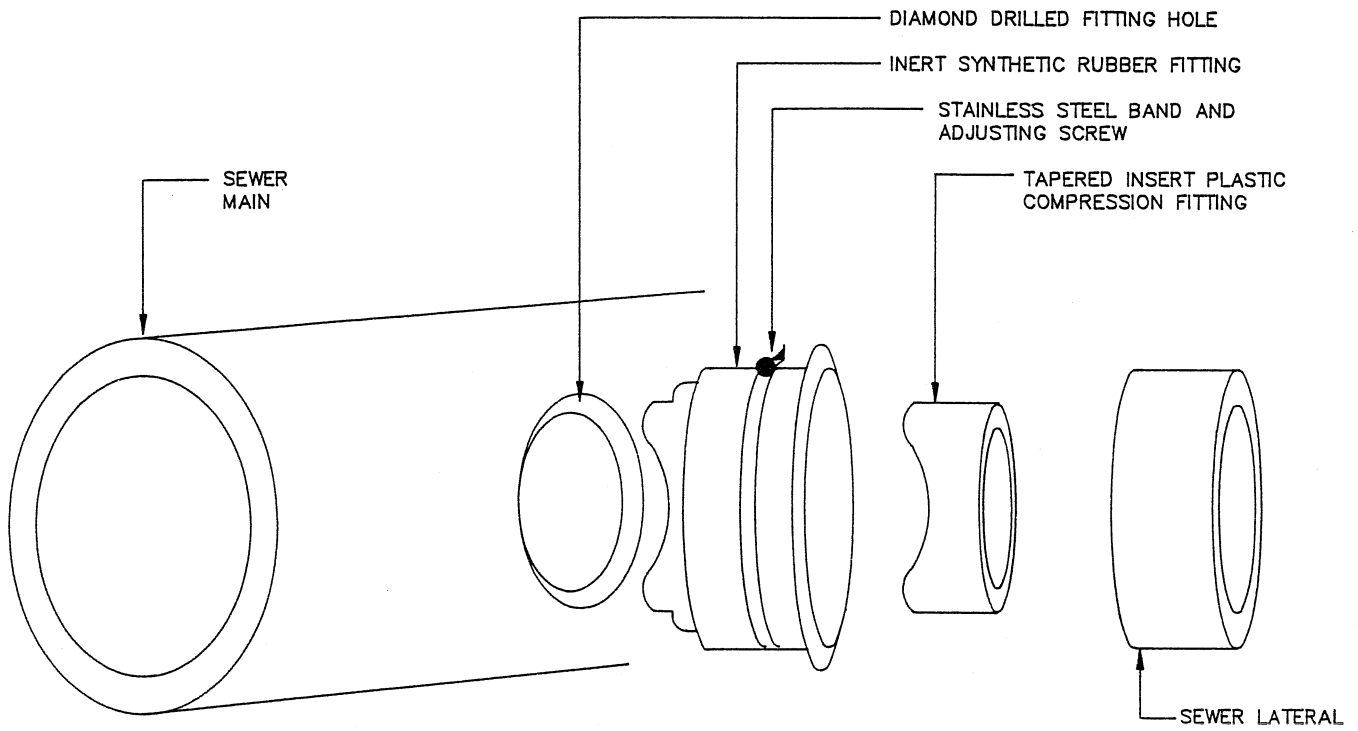

## SEWER LATERAL CONNECTION DETAIL

CITY OF HOLLISTER  
STANDARD PLANS

APPROVED: *Max H. Bridges*

MAX H. BRIDGES R.C.E. 24152- EXP. 12/31/93

DATE APRIL 30, 1992

REVISED

DETAIL C-6

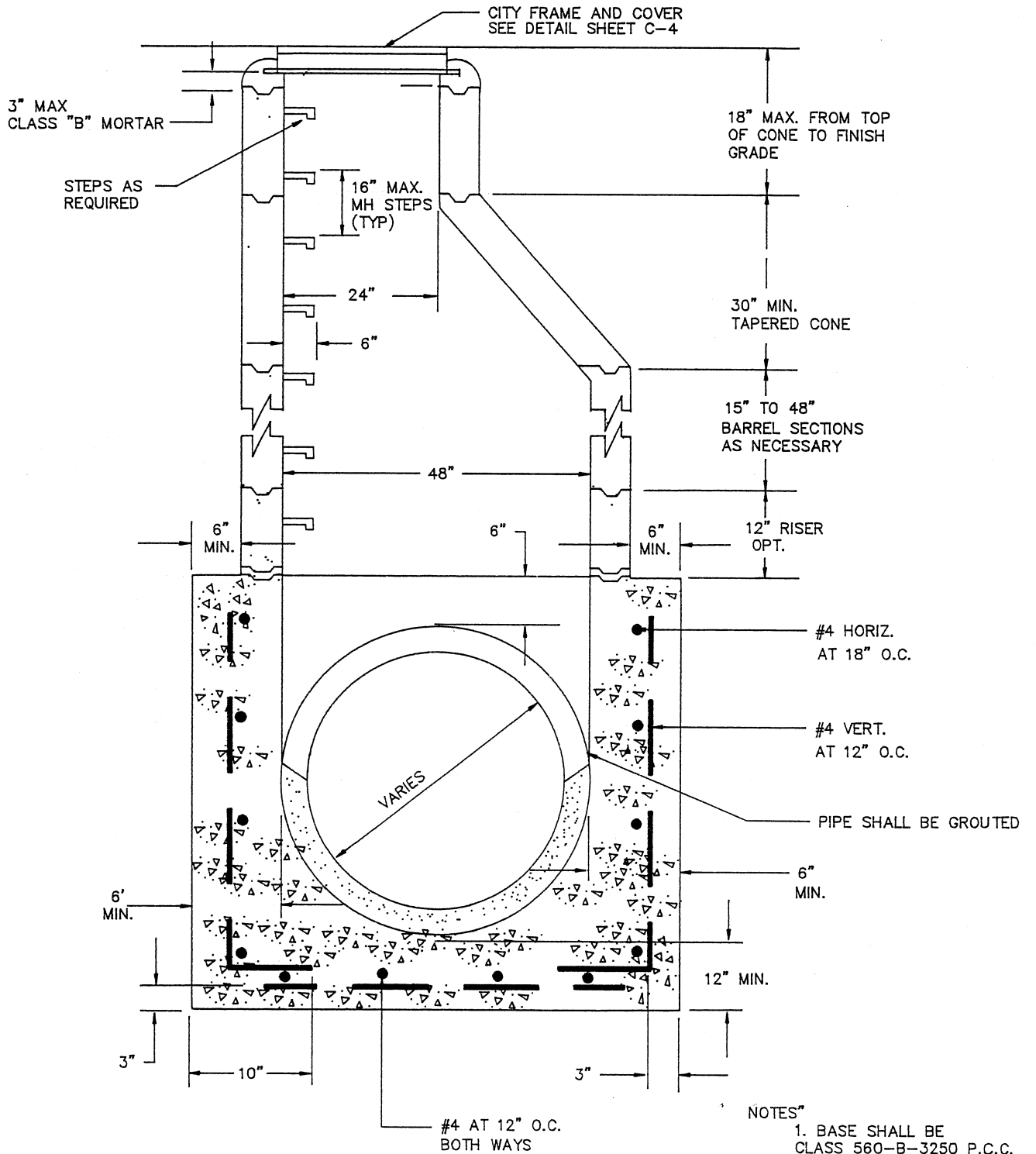

SECTION A-A

NOTES

1. BASE SHALL BE CLASS 560-B-3250 P.C.C.
2. SEE STANDARD DETAIL C-2 FOR CONSTRUCTION AND MATERIAL NOTES
2. ALL REINFORCING BARS SHALL BE PREFORMED BILLET BARS AS PER ASTM A615

TYPE II ECCENTRIC MANHOLE (36" TO 48")

CITY OF HOLLISTER  
STANDARD PLANS

APPROVED:

*Max H. Bridges*  
MAY H. BRIDGES P.C.E. 24152 EXP. 12/31/03

DATE

APRIL 30, 1992

REVISED

DETAIL

D-1-1

SHEET 1 OF 2

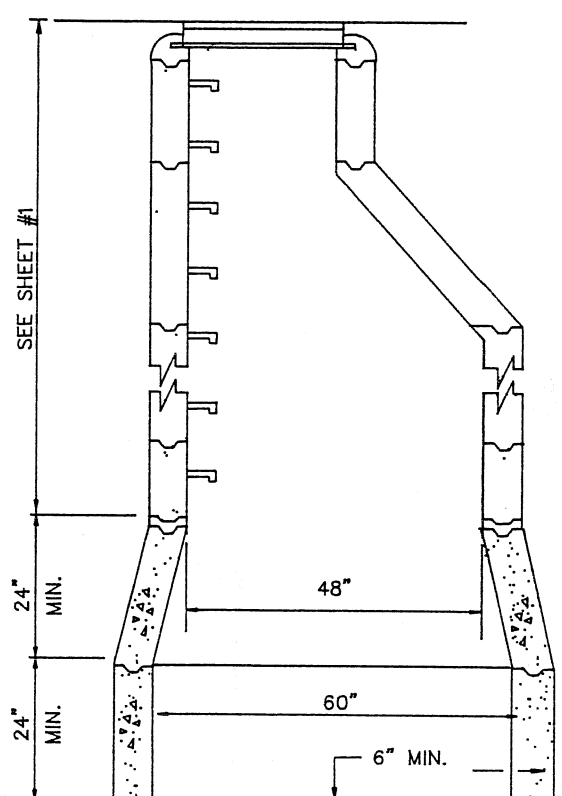

STANDARD PRECAST 5' DIA. MANHOLE BARREL CENTERED ON BASE

LINE OF MH STEPS

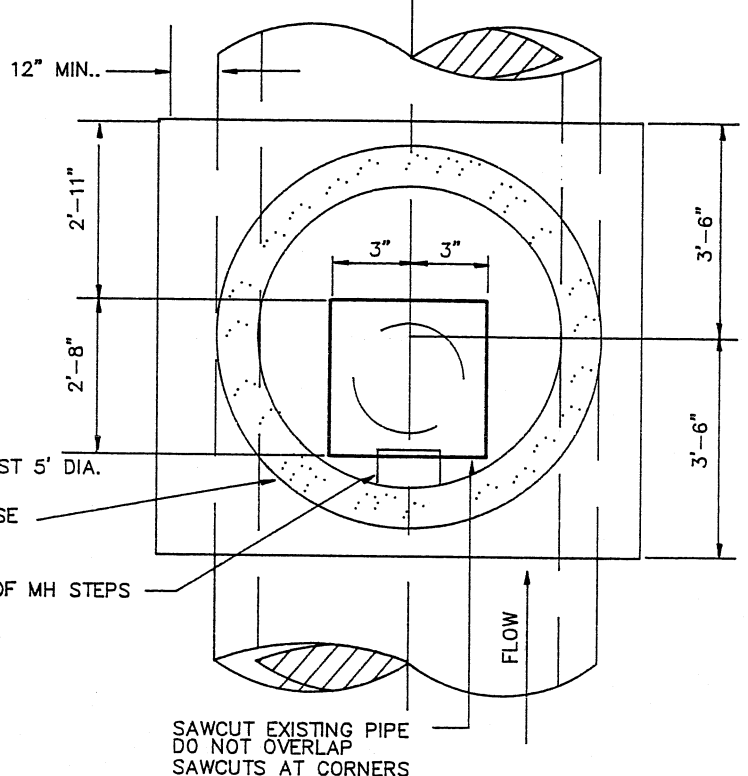

PLAN VIEW

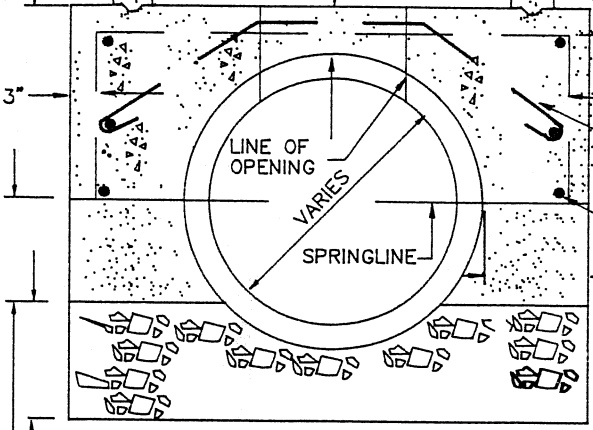

SECTION A - A

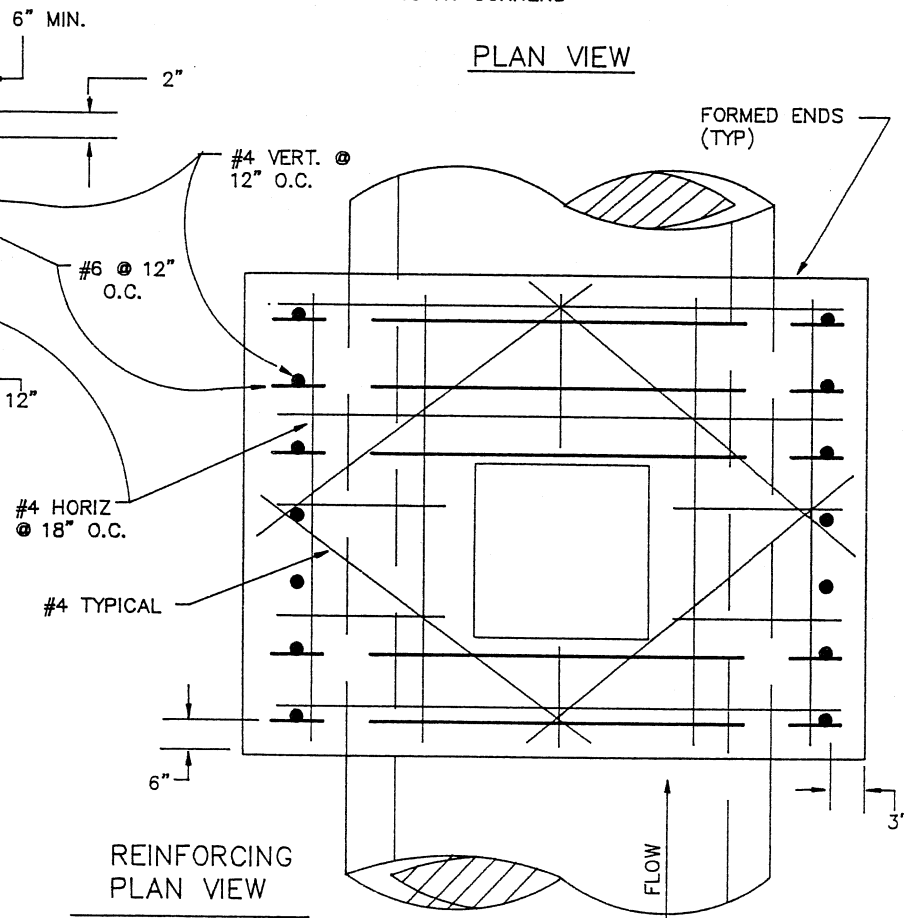

REINFORCING PLAN VIEW

TYPE III ECCENTRIC MH (51" & LARGER PIPE)  
 CITY OF HOLLISTER  
 STANDARD PLANS

APPROVED: *[Signature]*  
 MAX H. BRIDGES R.C.E. 24152 - EXP. 12/31/03

DATE	APRIL 30, 1992
REVISED	
DETAIL	D-1-2 SHEET 2 OF 2

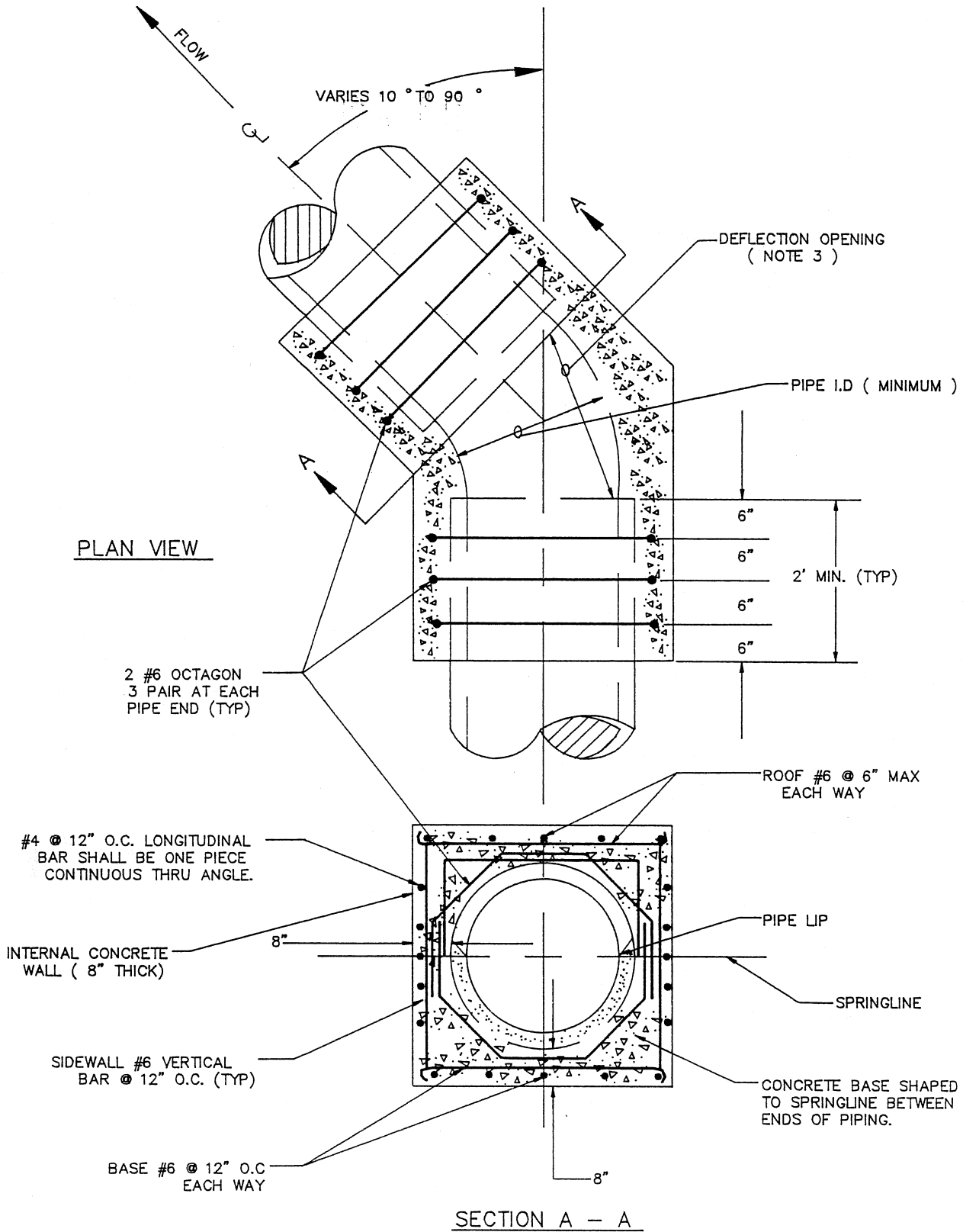

# ANGLE MANHOLE P.I. BASE

CITY OF HOLLISTER  
STANDARD PLANS

APPROVED:

*Max H. Bridges*  
MAX H. BRIDGES R.C.E. 24152- EXP. 12/31/93

DATE

APRIL 30, 1992

REVISED

DETAIL

D-2-1

SHEET 1 OF 2

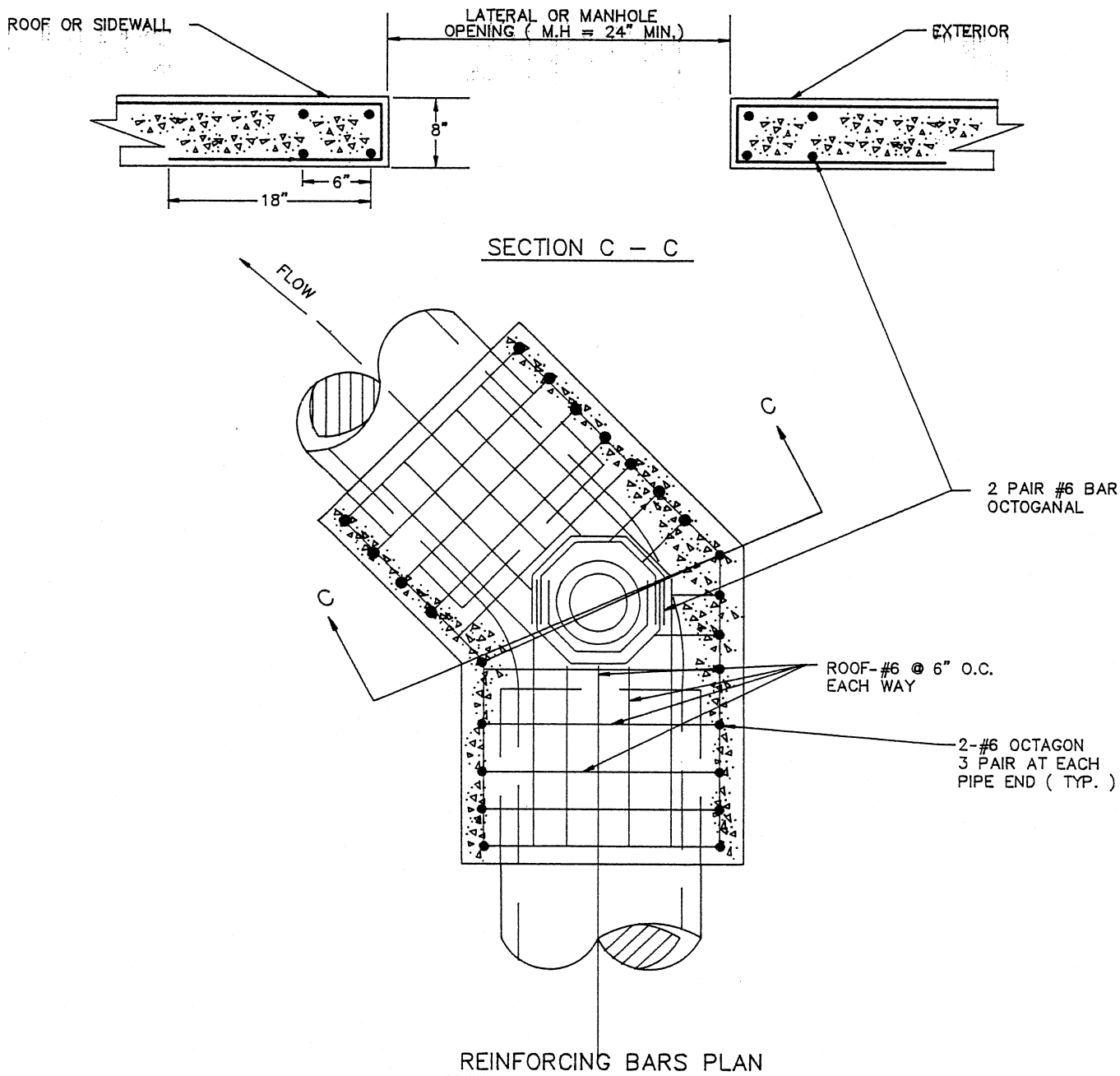

NOTES:

1. THE CONTRACTOR MAY ELECT TO CONSTRUCT A S.D. ANGLE M.H. BASE WHERE A MITER BEND IS CALLED FOR ON THE PLANS.
2. THE CONCRETE FOR ANGLE M.H. SHALL BE CLASS 560-C-3500 P.C.C. ( MAX. SLUMP 5" ).
3. IF THE DEFLECTION OPENING EXCEED 54" FOR 54" OR LARGER MAIN OR 42" FOR 48" OR SMALLER MAIN, A ANGLE MANHOLE BASE SHALL BE REQUIRED.
4. ALL REINFORCING BARS SHALL BE BILLET STEEL BARS AS PER ASTM A 615.
5. THE CONCRETE SHALL BE VIBRATED OR TAMPED UNTILL CONCRETE HAS BEEN CONSOLIDATED
6. NO POURING OF CONCRETE WILL BE MADE UNTIL THE PUBLIC WORKS INSPECTOR APPROVES THE FORMS AND REBARS.
7. THE INTERIOR OF THE ANGLE MANHOLE BASE SHALL HAVE A SMOOTH TROWELED FINISH.

# ANGLE MANHOLE P.I. BASE

CITY OF HOLLISTER  
STANDARD PLANS

APPROVED: *[Signature]*

MAX H. BRIDGES R.C.E. 24152- EXP. 12/31/93

DATE	APRIL 30, 1992
REVISED	
DETAIL	D-2-2 SHEET 2 OF 2

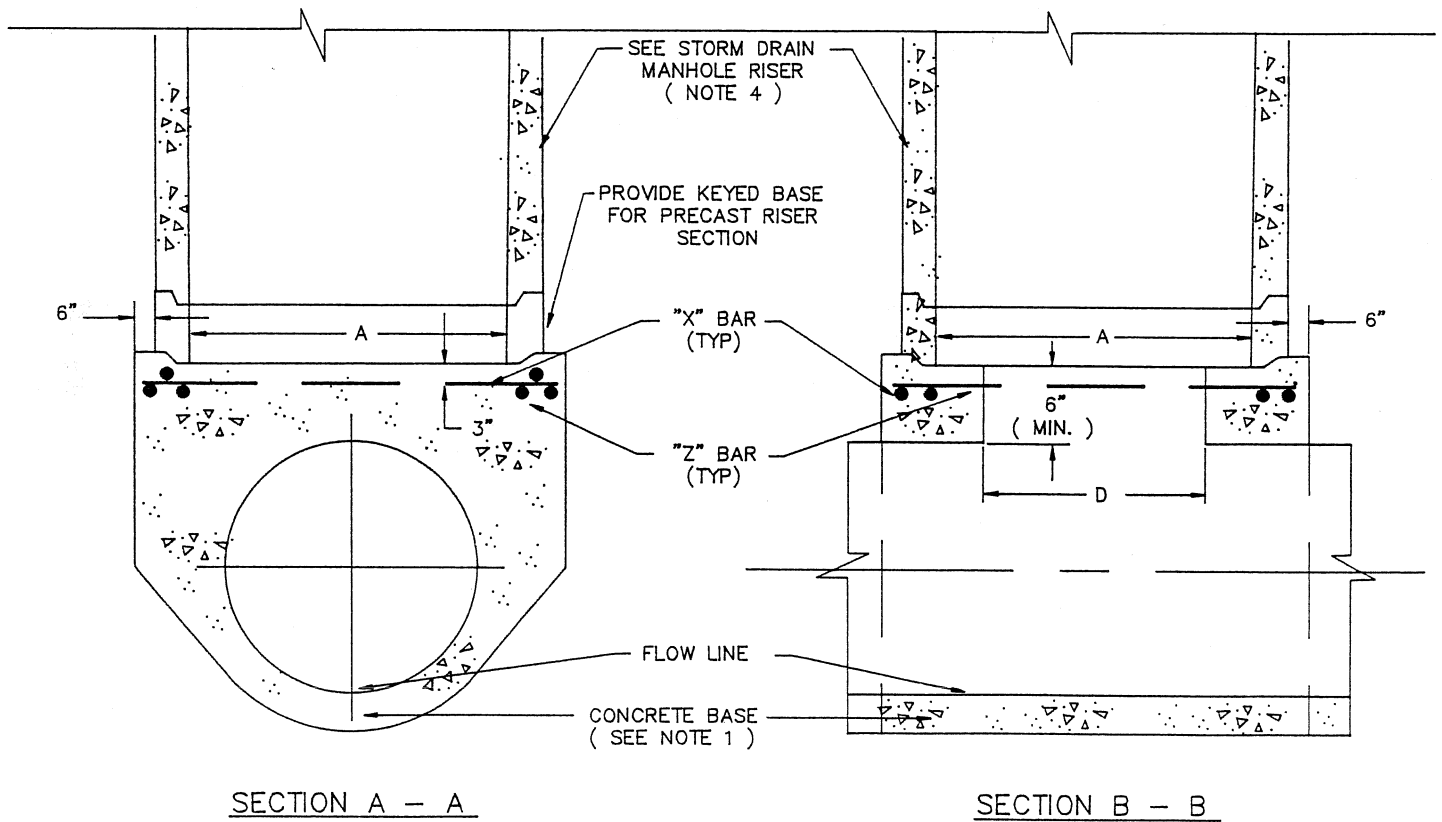
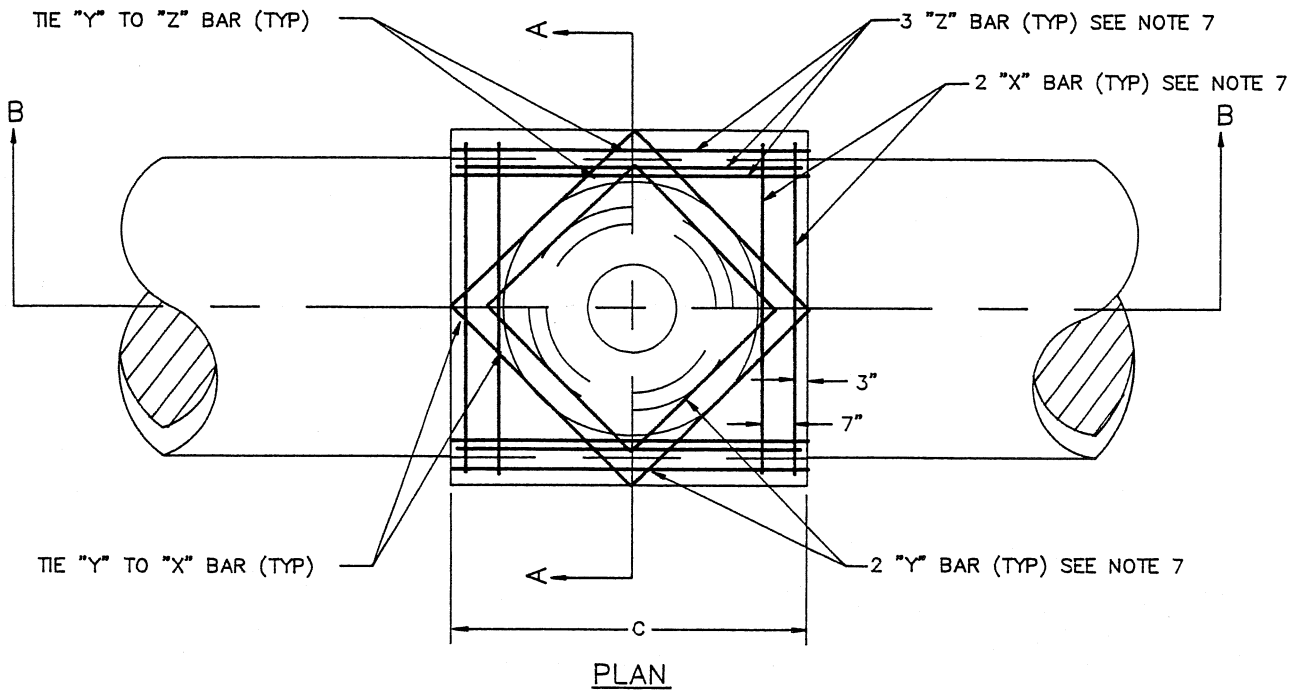

STRAIGHT THROUGH CAST-IN-PLACE MH  
 CITY OF HOLLISTER  
 STANDARD PLANS

APPROVED: *Max H. Bridges*  
 MAX H. BRIDGES, R.C.E. 24152 - EXP. 12/31/93

DATE	APRIL 30, 1992
REVISED	
DETAIL	D-3-1 SHEET 1 OF 2

DIMENSIONS					REINFORCEMENT					
PIPE DIAMETER (INCHES)	A (IN)	B (IN)	C (FT)	D (IN)	BAR "X"		BAR "Y"		BAR "Z"	
					#	L	#	L	#	L
30" AND SMALLER	48	18 (MIN)	5'-6"	*						
36"	48	14	5'-6"	32	* MATCH PER DIAMETER					
42"	48	11	5'-6"	38						
48"	48	9	6	44						
54"	60	14	7	54						
60"	60	10	7	54	5	6'-0"	5	2'-6"	5	6'-6"
66"	60	10	7	54	5	6'-6"	5	2'-6"	5	6'-6"
72"	60	12	8	54	5	7'-0"	5	3'-0"	5	7'-0"
					5	7'-6"	5	4'-0"	5	7'-6"

NOTES:

1. ALL CONCRETE SHALL BE CLASS 560-C-3500 P.C.C. ( MAX. SLUMP 5" )
2. CONCRETE SHALL BE VIBRATED OR TAMPED UNTIL THE CONCRETE HAS BEEN CONSOLIDATED.
3. ALL REINFORCING BARS SHALL BE BILLET STEEL BARS FOR CONCRETE REINFORCEMENT CONFORMING TO THE SPECIFICATION OF ASTM A615 (GRADE 40 OR 60 ).
4. THE STORM DRAIN RISER DETAILS SHALL BE: FOR 48" DIA. AND SMALLER STANDARD PLAN D-1-1, FOR 54" DIA. AND LARGER STANDARD DETAIL D-1-2.
5. THE INTERIOR OF THE MANHOLE BASE SHALL HAVE A SMOOTH TROWELLED SURFACE.
6. NO REINFORCING BARS ARE REQUIRED ON 48" DIA. AND SMALLER PIPE.

STRAIGHT THROUGH CAST-IN-PLACE MH

CITY OF HOLLISTER

STANDARD PLANS

APPROVED:

*Max H. Bridges*

MAX H. BRIDGES R.C.E. 24152- EXP. 12/31/93

DATE

APRIL 30, 1992

REVISED

DETAIL

D-3-2

SHEET 2 OF 2

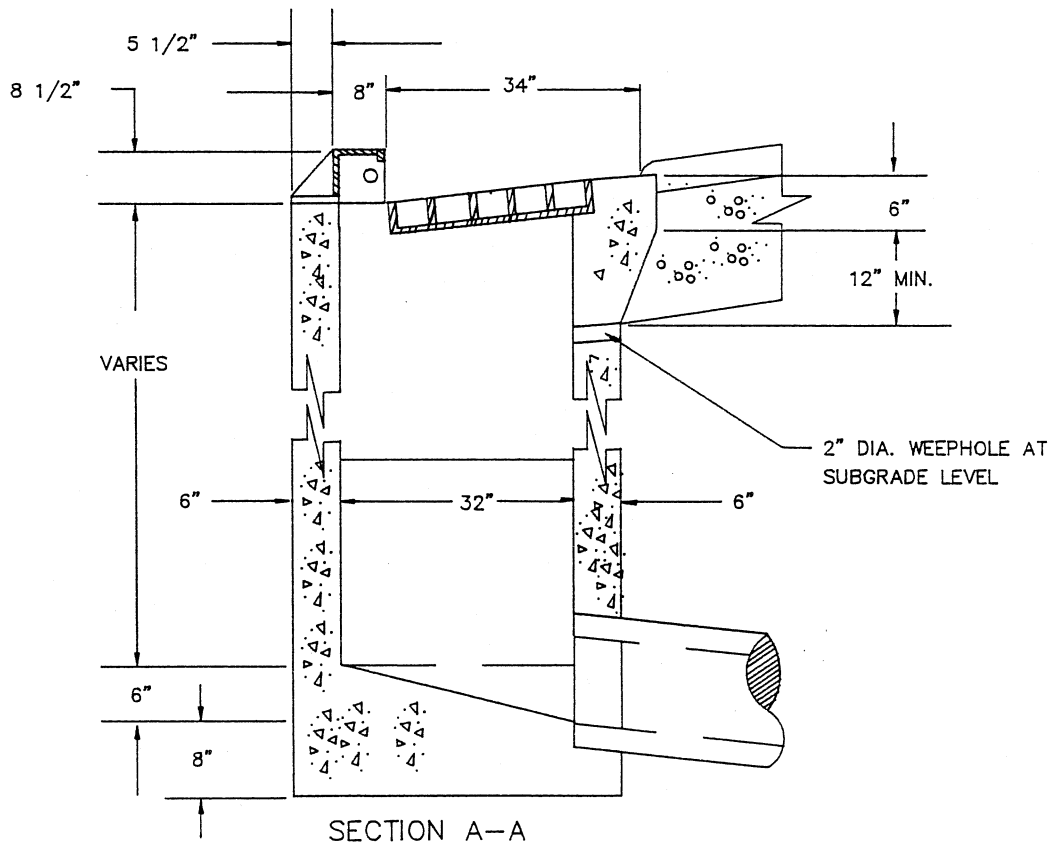
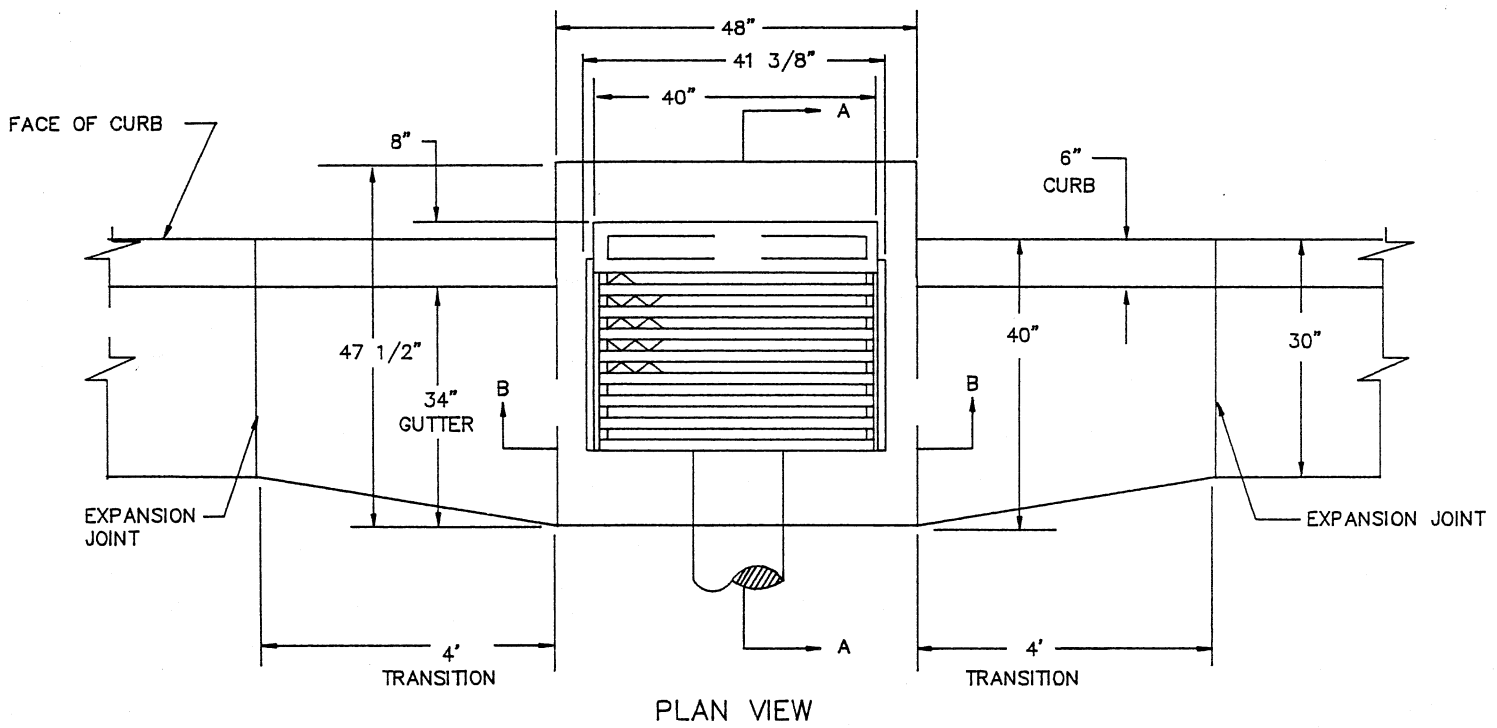

- NOTES:
1. SEE NOTES AND SECTION B-B ON DETAIL SHEET D-6.
  2. SEE DETAIL SHEET D-8 FOR HOOD, FRAME AND GRATE.

# TYPE "A" CURB INLET CATCH BASIN ( 24"X36" )

CITY OF HOLLISTER  
STANDARD PLANS

APPROVED:

*Max H. Bridges*  
MAX H. BRIDGES R.C.E. 24152- EXP. 12/31/93

DATE

APRIL 30, 1992

REVISED

DETAIL

D-4 SHEET 1 OF 1



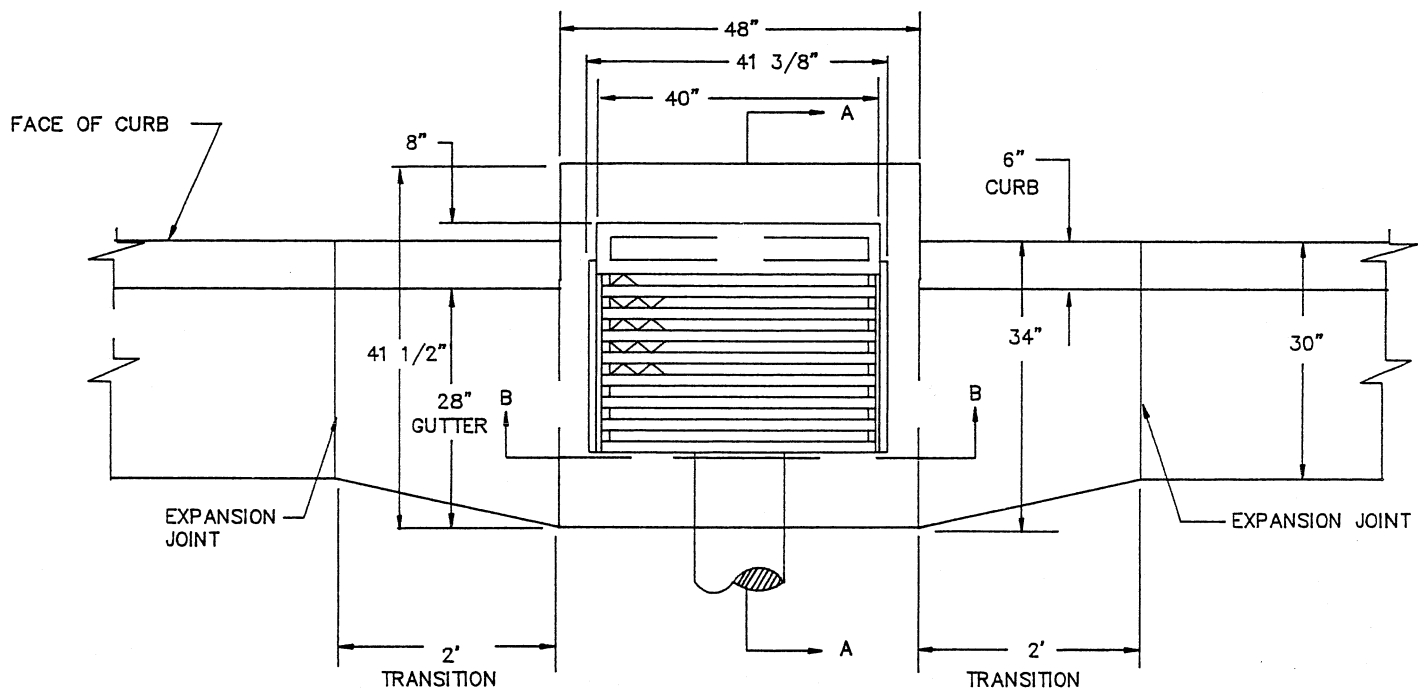

PLAN VIEW

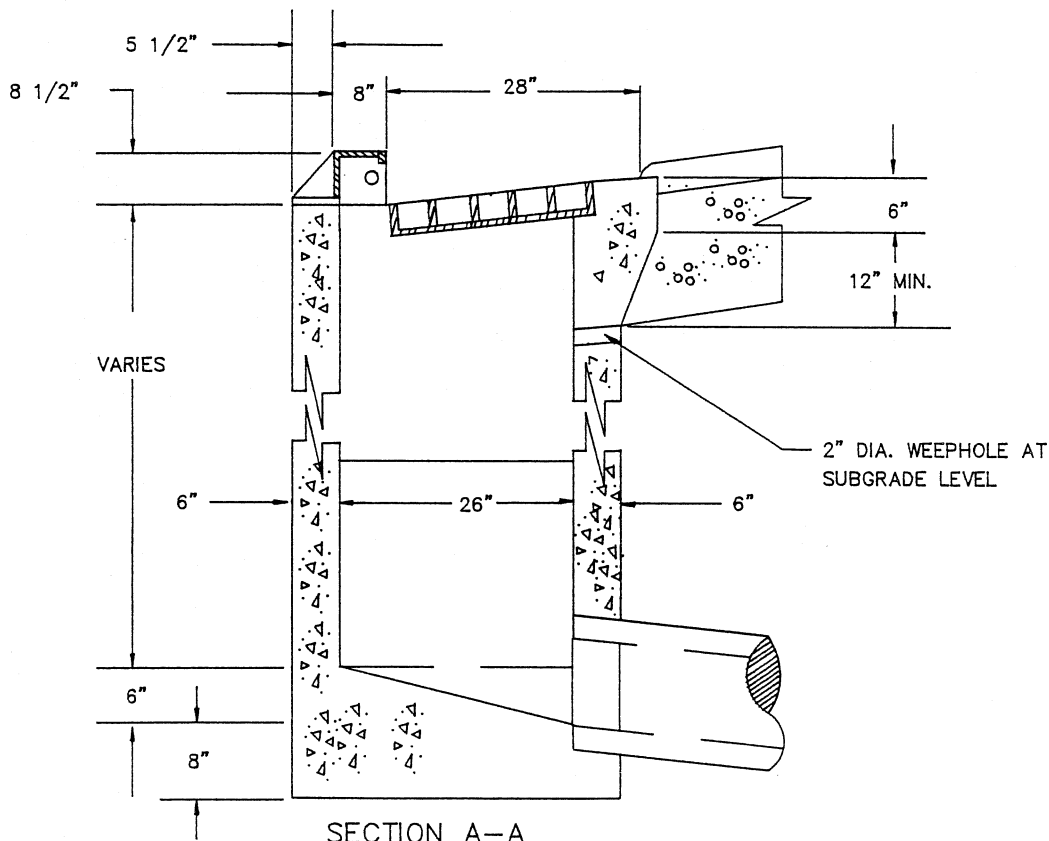

SECTION A-A

NOTES:

1. SEE NOTES AND SECTION B-B ON DETAIL SHEET D-6.
2. SEE DETAIL SHEET D-8 FOR HOOD, FRAME AND GRATE.

# TYPE "B" CURB INLET CATCH BASIN ( 18"X36" )

CITY OF HOLLISTER  
STANDARD PLANS

APPROVED: \_\_\_\_\_

*Max H. Bridges*  
MAX H. BRIDGES, P.E. 24152 - EXP. 12/31/93

DATE	APRIL 30, 1992
REVISED	
DETAIL	D-5 SHEET 1 OF 1

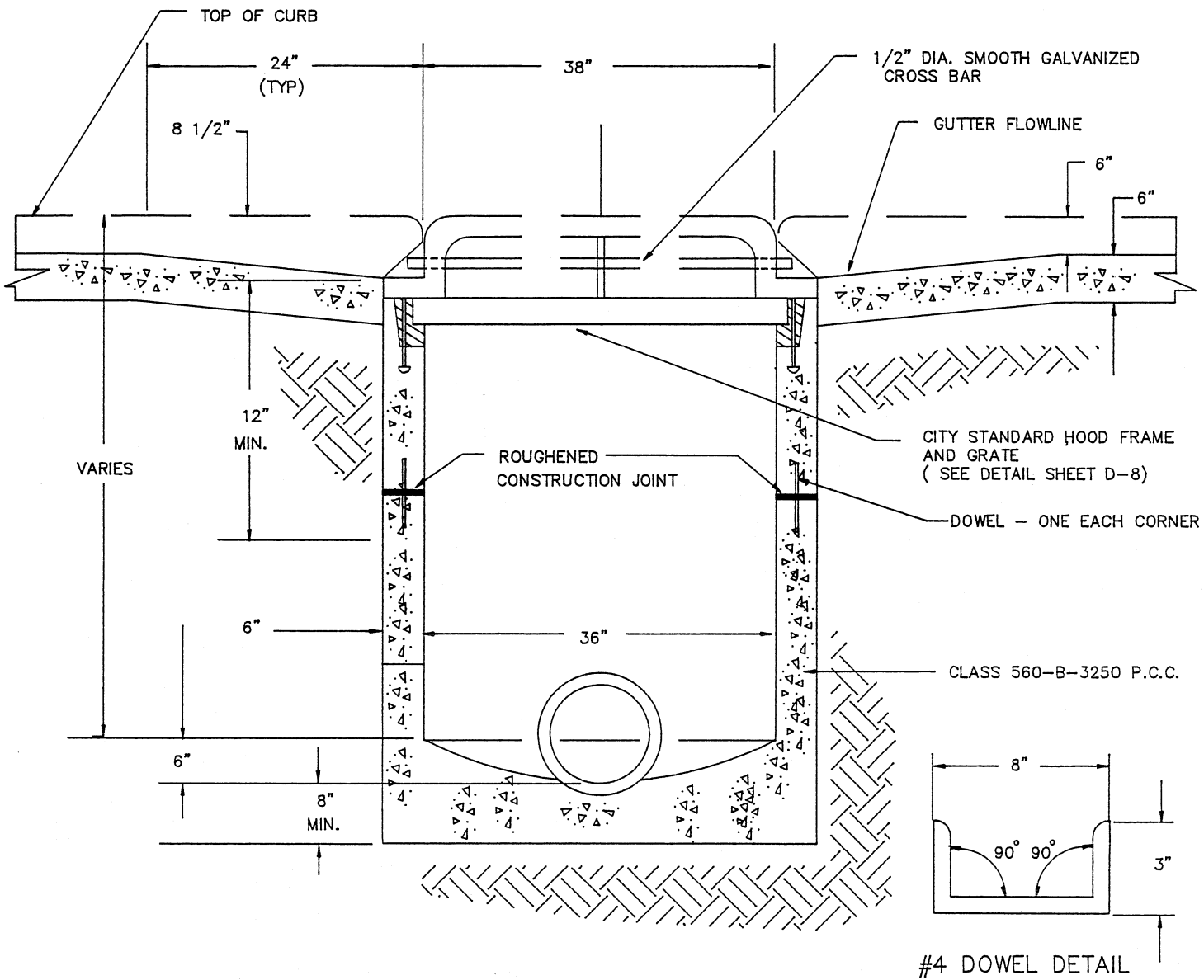

SECTION B-B

NOTES:

1. PRECAST INLETS MAY BE USED SUBJECT TO WRITTEN APPROVAL OF THE CITY ENGINEER. EXCAVATION TO BE MIN. 4" LARGER THAN PRECAST BOX ON ALL SIDES. BACKFILL WITH CLASS 100-E-100 P.C.C.
2. INLET BASE TO BE POURED AGAINST UNDISTURBED EARTH.
3. INLET WALLS MAY BE POURED TO AN ELEVATION NOT LESS THAN 1'-0" FROM GUTTER LINE. DOWELS SHALL BE PROVIDED AT EACH CORNER OF BOX. THE UPPER 1'-0" OF THE INLET BOX SHALL BE FRAMED AND POURED MONOLITHICALLY WITH THE CURB AND GUTTER.
4. NO CONCRETE MAY BE POURED PRIOR TO CHECKING OF FORMS BY THE PUBLIC WORKS INSPECTOR.
5. PIPES MAY BE PLACED IN ANY WALL.
6. WHEN CURB GUTTER AND SIDEWALK ARE NOT POURED MONOLITHIC, THE CONCRETE CURB POUR SHALL ALSO ENCASE SIDES AND BACK OF HOOD A MINIMUM OF 8" WIDE AND 8" DEEP. ENCASUREMENT SHALL BE POURED IN A FORM TO PROVIDE STRAIGHT EDGES.
7. REINFORCING BARS SHALL BE REQUIRED IN WALLS WHICH ARE MORE THAN 6' DEEP. HORIZONTAL AND VERTICAL BARS SHALL BE #4, SPACED 12" O.C. AND PLACED 2" CLEAR OF INSIDE WALL SURFACE.

# CURB INLET CATCH BASIN DETAIL & NOTES

CITY OF HOLLISTER  
STANDARD PLANS

APPROVED: *Max H. Bridges*

MAY H. BRIDGES P.C.E. 24152 - EXP. 12/31/93

DATE	APRIL 30, 1992
REVISED	
DETAIL	D-6

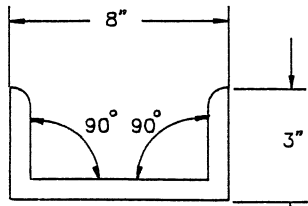

#4 DOWEL DETAIL

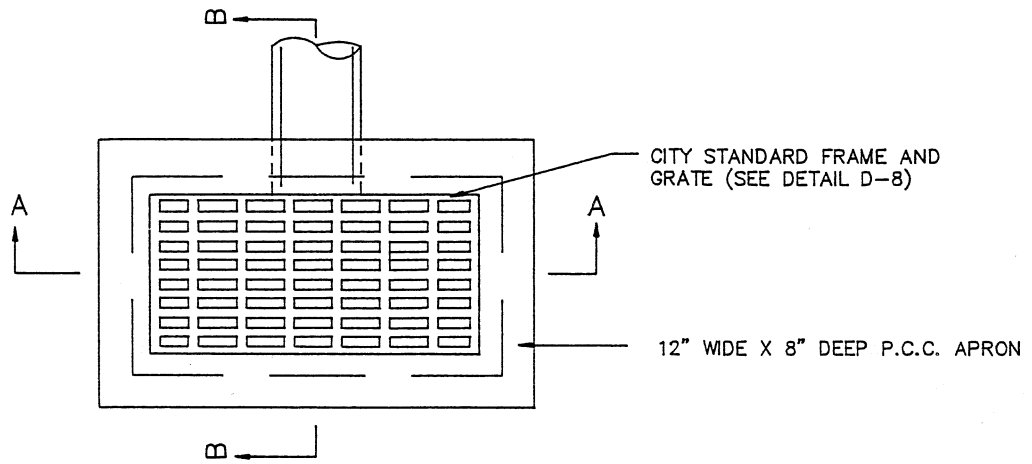

PLAN VIEW

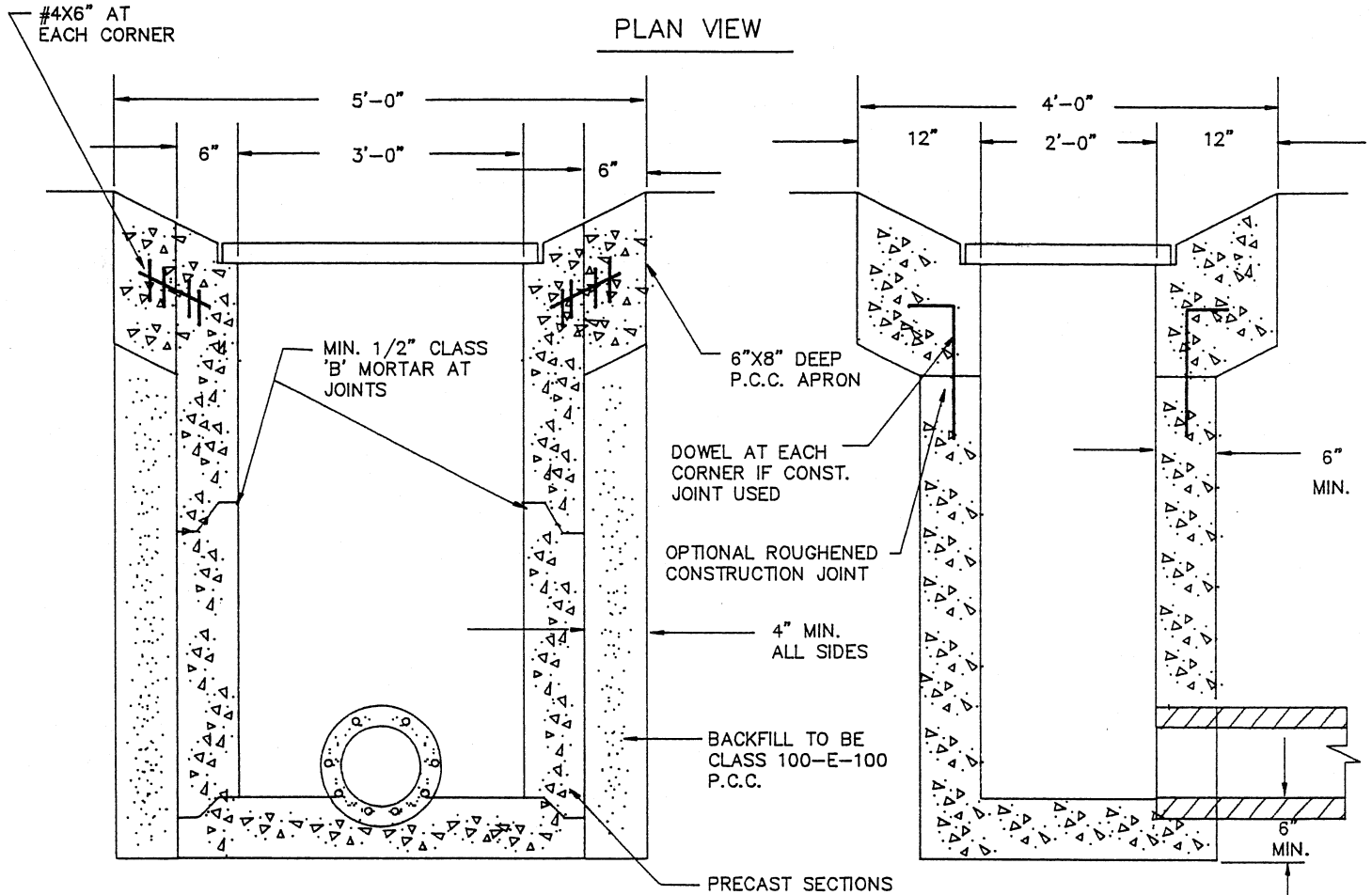

SECTION A-A

SECTION B-B

NOTES: ( PRECAST BOX CONSTRUCTION )

( POURED IN PLACE CONSTRUCTION )

1. PRECAST INLETS MAY BE USED AT CONTRACTORS OPTION FOR DEPTHS UP TO 6 FEET.
2. INLET BASE TO BE POURED AGAINST UNDISTURBED EARTH.
3. NO CONCRETE MAY BE POURED PRIOR TO CHECKING FORMS BY THE PUBLIC WORKS INSPECTOR.
4. PIPES MAY BE PLACED IN ANY WALL.
5. REINFORCING BARS SHALL BE REQUIRED IN WALLS WHICH ARE MORE THAN 6' DEEP. HORIZONTAL AND VERTICAL BARS SHALL BE #4, SPACE 12" O.C. AND PLACED AT 2" CLEAR OF INSIDE WALL SURFACE.

# DROP INLET (24" X 36")

CITY OF HOLLISTER  
STANDARD PLANS

APPROVED: *Max H. Bridges*

MAX H. BRIDGES, P.C.E. 24152 EXP. 12/31/03

DATE	APRIL 30, 1992
REVISED	
DETAIL	D-7

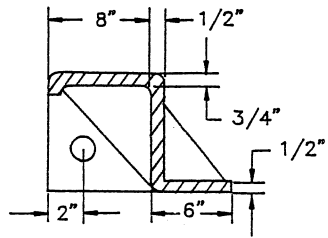
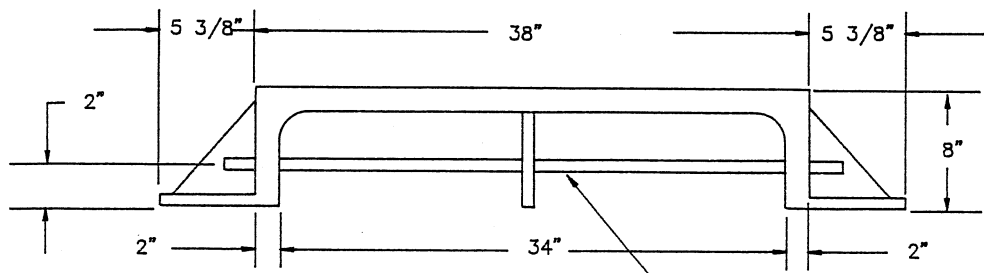

SECTION A-A

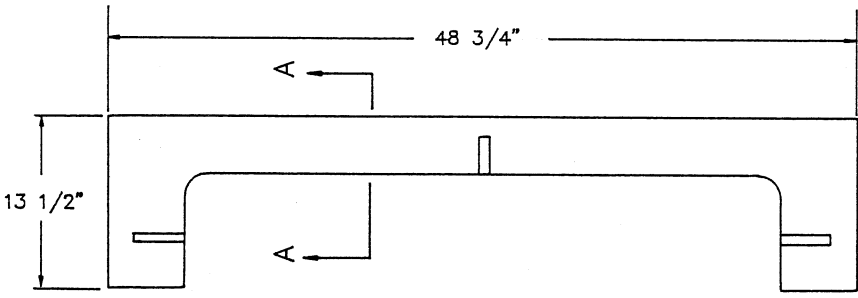

CAST IRON HOOD

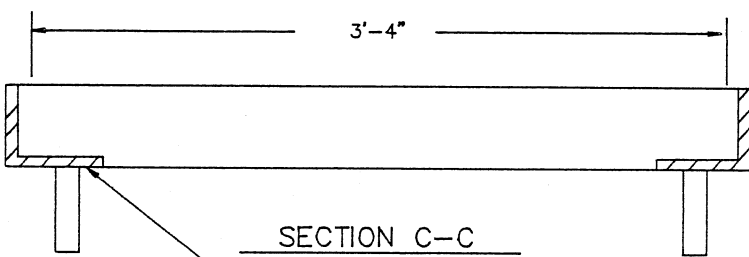

SECTION C-C

- NOTES:
1. HOOD TO BE CAST IRON DIPPED IN ASPHALT PAINT.
  2. FRAME AND GRATES TO BE GALVANIZED AFTER FABRICATION.

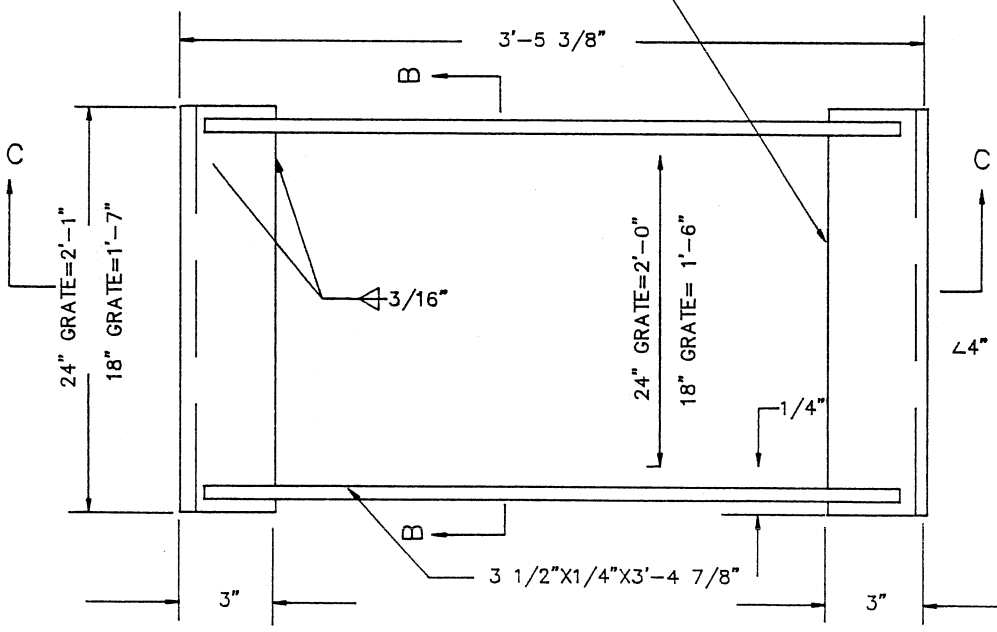

WELDED STEEL FRAME

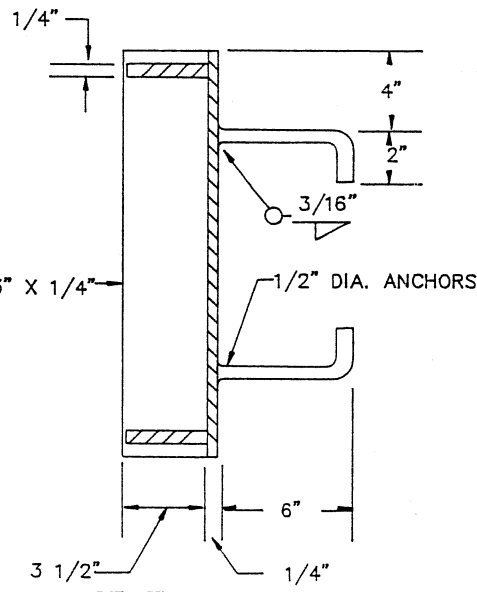

SECTION B-B

INLET HOOD, FRAME AND GRATES

CITY OF HOLLISTER

STANDARD PLANS

APPROVED: *Max H. Bridges*

MAX H. BRIDGES R.C.E. 24152 - EXP. 12/31/93

DATE: **APRIL 30, 1992**

REVISED:

DETAIL: **D-8-1** SHEET 1 OF 2

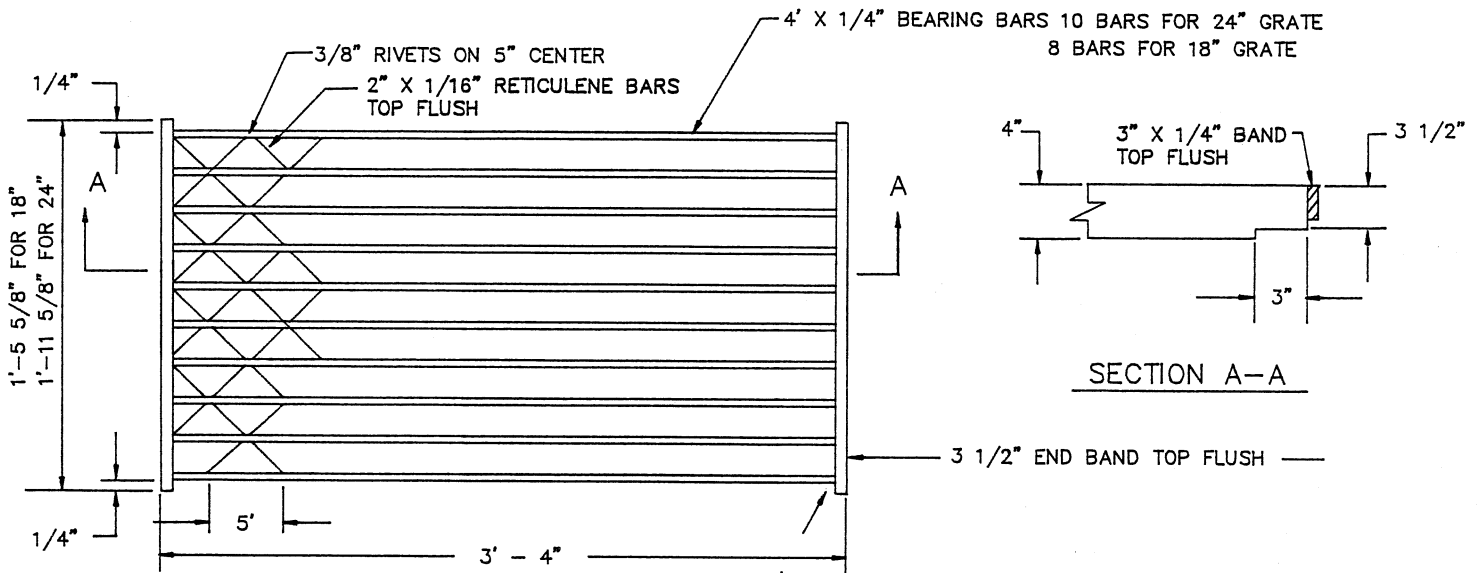

**WELDED STEEL  
RETICULENE GRATE**

WT. OF 24" GRATE = 182 LBS.  
WT. OF 18" GRATE = 145 LBS.

3/16" FILLET WELD FULL DEPTH  
EACH SIDE. ON OUTSIDE BEARING  
BAR AND EVERY OTHER INTERNAL BAR

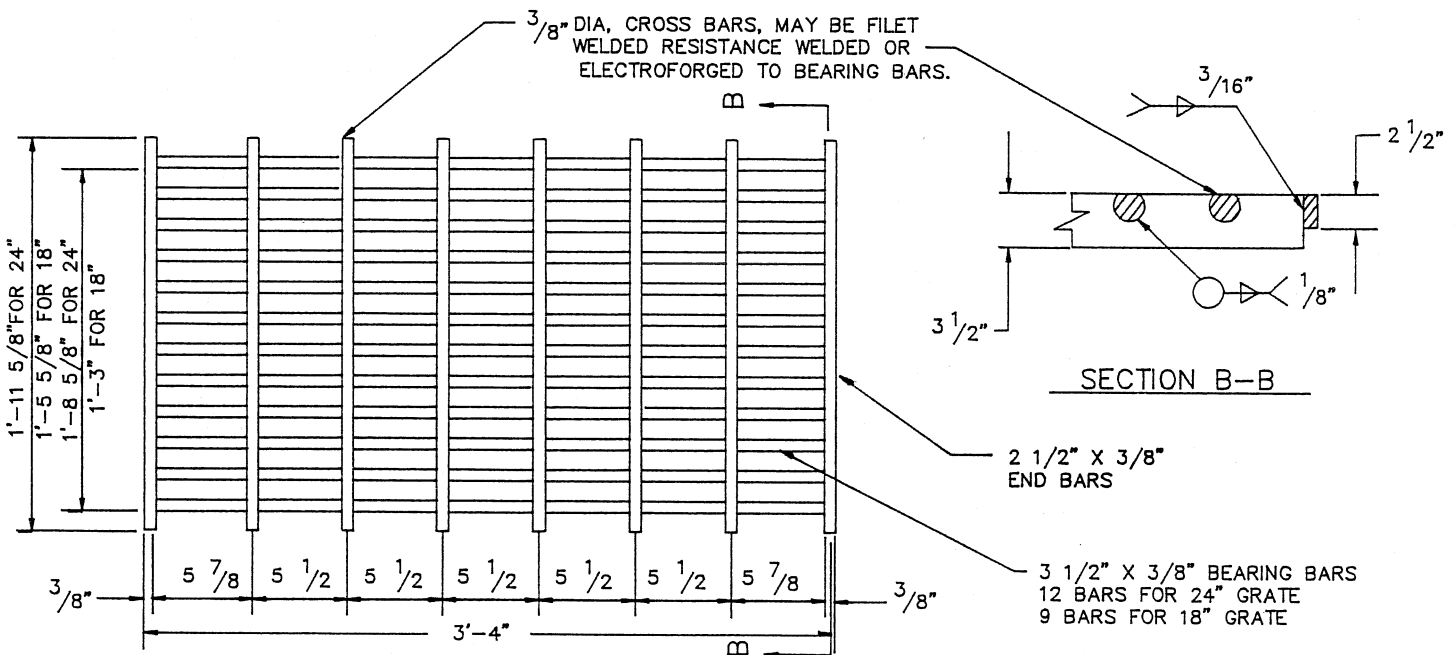

**WELDED STEEL GRATE**

WT. OF 24" GRATE = 192 LBS.  
WT. OF 18" GRATE = 145 LBS.

**NOTES"**

1. FRAMES AND GRATES TO BE GALVANIZED AFTER FABRICATION.
2. EITHER WELDED STEEL GRATE MAY BE USED AT CONTRACTORS OPTION.

**INLET HOOD, FRAME AND GRATES**

**CITY OF HOLLISTER**

STANDARD PLANS

APPROVED: *Max H. Bridges*

MAX H. BRIDGES R.C.E. 24152- EXP. 12/31/93

DATE

APRIL 30, 1992

REVISED

DETAIL

D-8-2 SHEET 2 OF 2

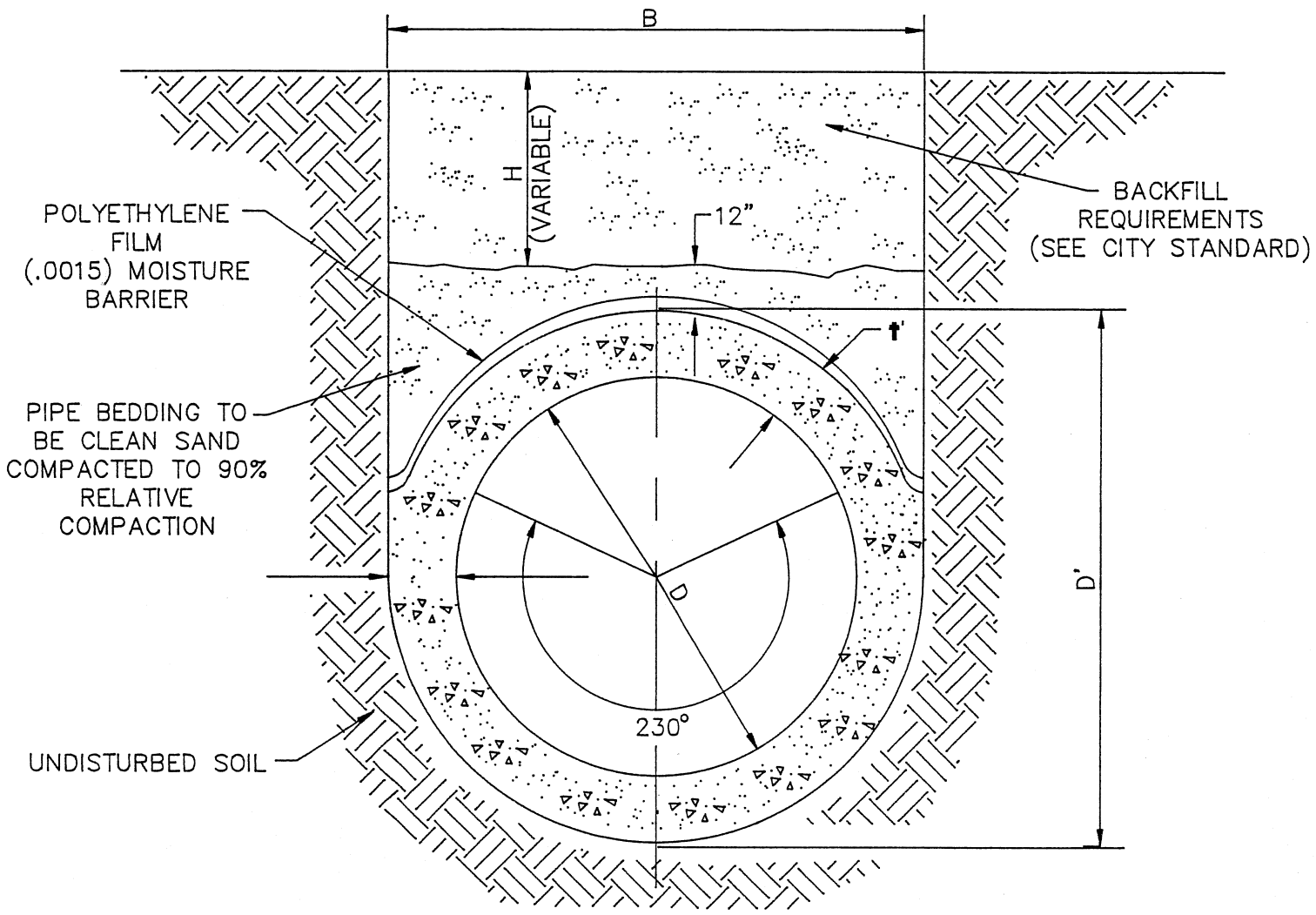

TYPICAL PIPE CROSS SECTION 24" THRU 96"  
 NOTE: CAST IN PLACE CONCRETE PIPE SHALL BE CLASS 560-C-4000 P.C.C.

DIMENSIONS OF CIP CONCRETE PIPE				
NOMINAL DIAMETER ( INTERIOR )	OUTER DIAMETER ( DEPTH )	WIDTH OF PIPE TRENCH ( NOMINAL )	NOMINAL THICKNESS ( MINIMUM )	SIDEWALL THICKNESS ( INTERIOR )
D	D'	B	↑	↑
24"	30"	30"	3"	3"
27"	33"	33"	3"	3"
30"	36"	36"	3"	3"
36"	43"	43"	3-1/2"	3-1/2"
42"	50"	50"	4"	4"
48"	58"	58"	5"	5"
54"	65"	65"	5-1/2"	5-1/2"
60"	72"	72"	6"	6"
66"	79"	79"	6-1/2"	6-1/2"
72"	86"	86"	7"	7"
84"	100"	100"	8"	8"
96"	114"	114"	9"	9"

CAST-IN-PLACE CONCRETE PIPE DETAIL

CITY OF HOLLISTER  
 STANDARD PLANS

APPROVED: *Max H. Bridges*

DATE	APRIL 30, 1992
REVISED	
DETAIL	D-9

MAY H. BRIDGES P.C.E. 24152 - EXP. 12/31/93

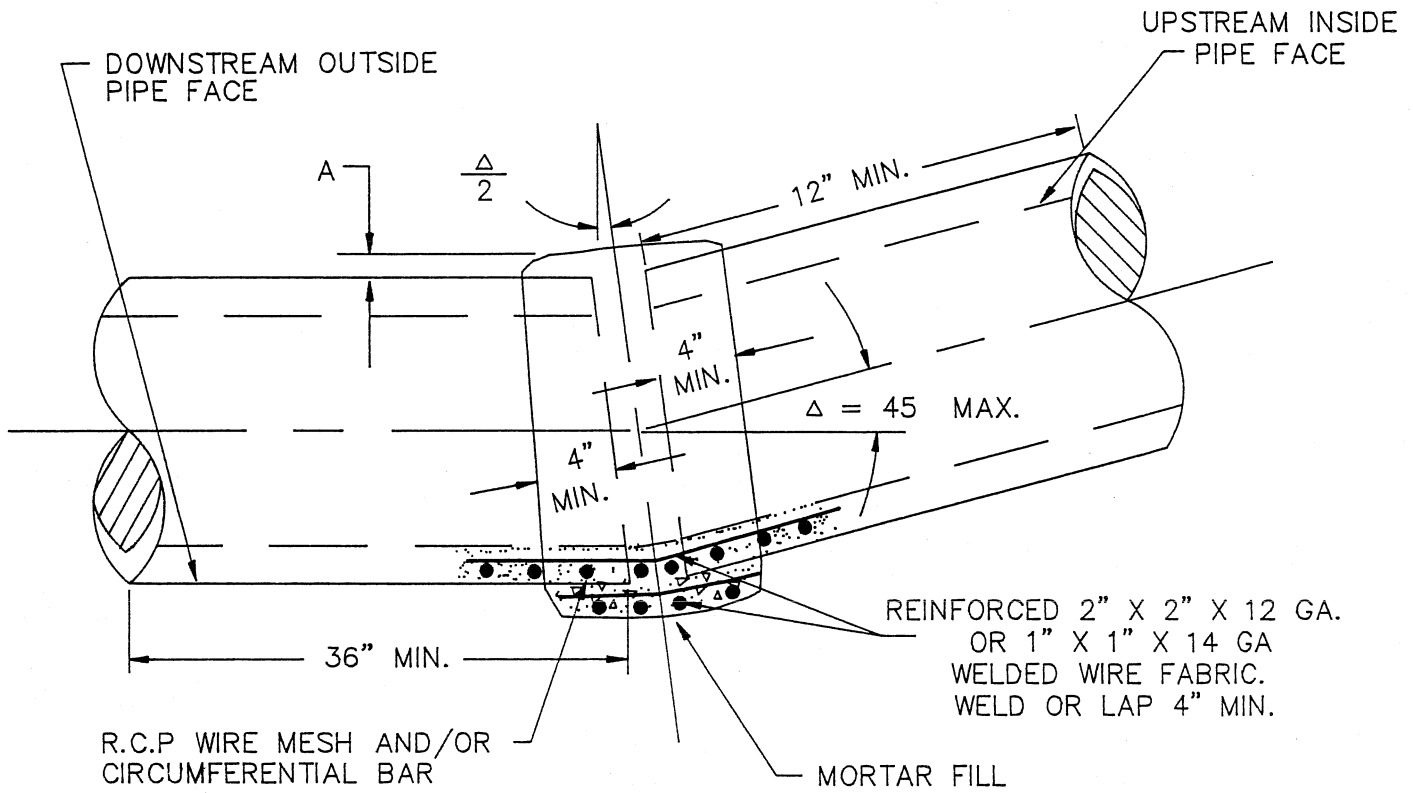

PIPE DIA. ( INCHES )	R.C.P. PIPE (MAX DEFLECTION PER JOINT)	CAST IN PLACE CONCRETE PIPE (MIN. ALLOWABLE RADIUS)	MINIMUM BAND THICKNESS ("A" IN)
24" & SMALLER	1 °30'	75 FEET	1 1/2"
27" TO 48"	1 °0'	150 FEET	2"
51" TO 60"	0 °45'	175 FEET	2 1/2"
66" & LARGER	0 °30'	200 FEET	3"

NOTES:

1. R.C.P. MITER BEND MAY BE INSTALLED INSTEAD OF S.D. MANHOLE WHEN THE PIPE DEFLECTION EXCEEDS THE MAXIMUM ALLOWABLE DEFLECTION. THE PROPOSED S.D. MANHOLE MUST BE RELOCATED TO A STRAIGHT SECTION OF PIPE.
2. REINFORCED CONCRETE PIPE (R.C.P) SHALL HAVE A MINIMUM OF CLASS III RATING.
3. MITER BEND SHALL BE PRE-CAST OR APPROVED EQUAL.

# REINFORCE CONCRETE PIPE MITER BEND

## CITY OF HOLLISTER

### STANDARD PLANS

APPROVED: \_\_\_\_\_

*M. S. Hill*

DATE	APRIL 30, 1992
REVISED	
DETAIL	D-10 SHEET 1 OF 1





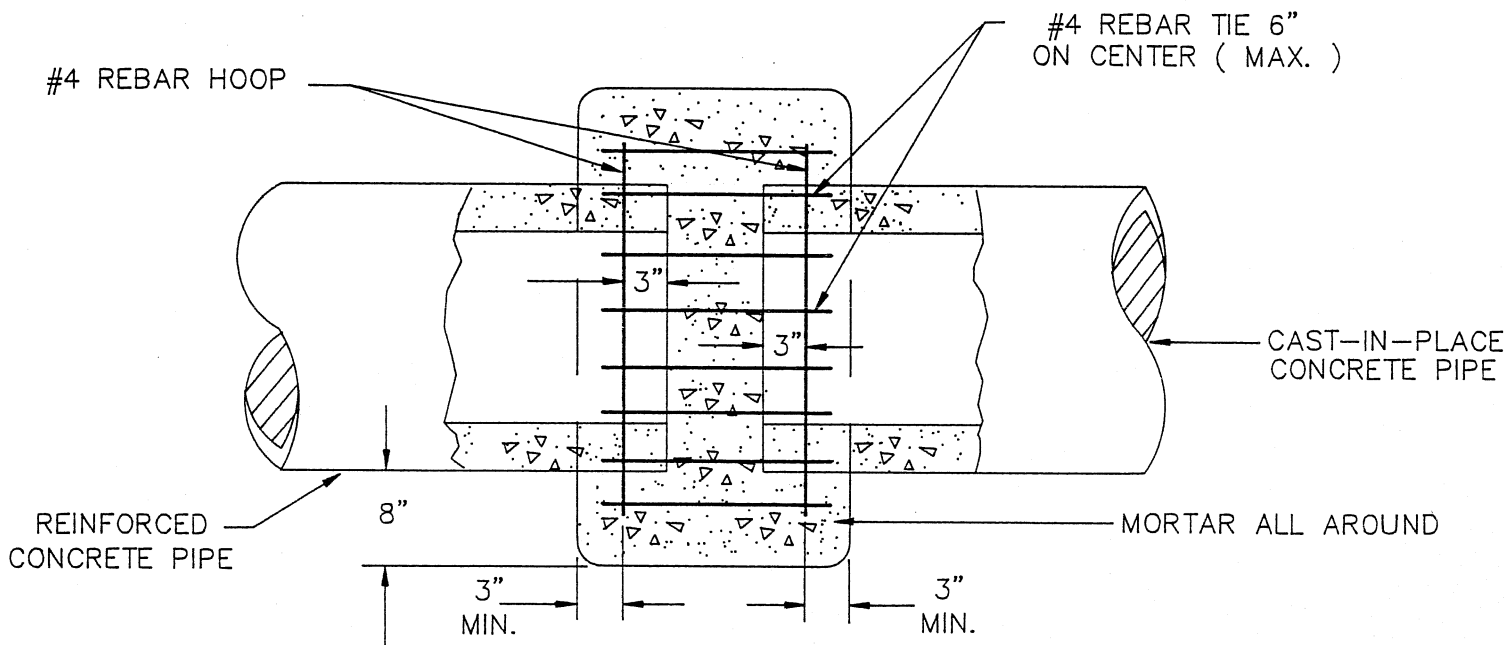

NOTES:

1. MORTAR SHALL BE CLASS "C" P.C.C.
2. CONCRETE SHALL BE CLASS 470-C-2000 P.C.C.
3. ALL REBAR SHALL BE BILLET STEEL BARS CONFORMING TO ASTM A615.

## STORM DRAIN STANDARD CONNECTION

CITY OF HOLLISTER

STANDARD PLANS

APPROVED: *W. A. Hill*

DATE	APRIL 30, 1992
REVISED	
DETAIL	D-12 SHEET 1 OF 1

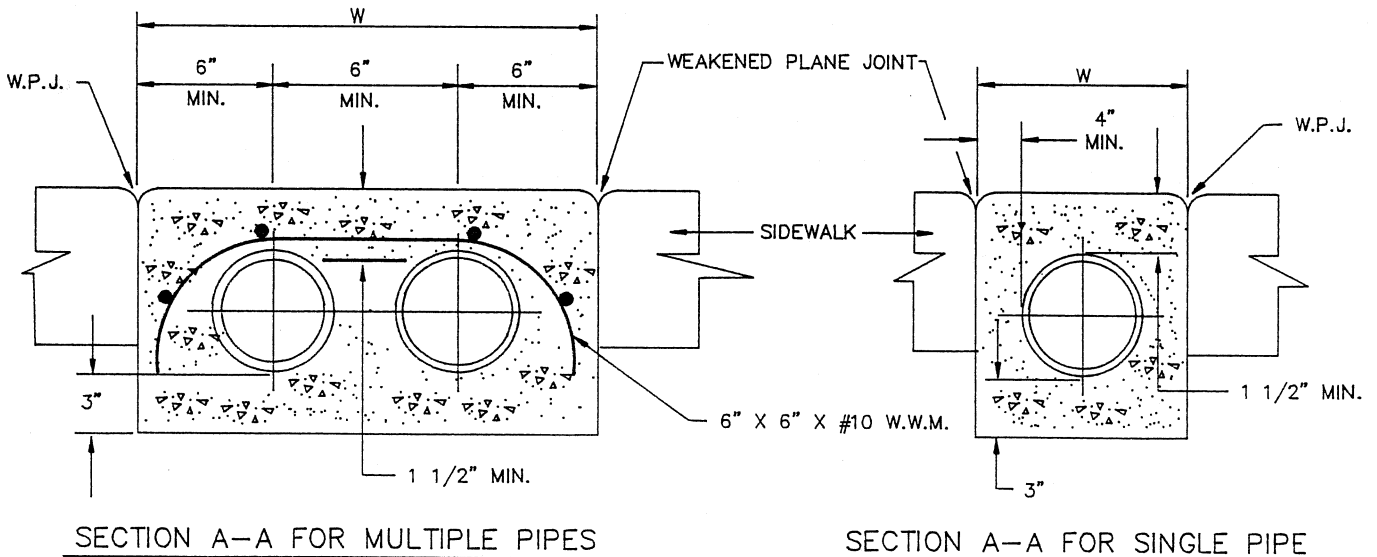
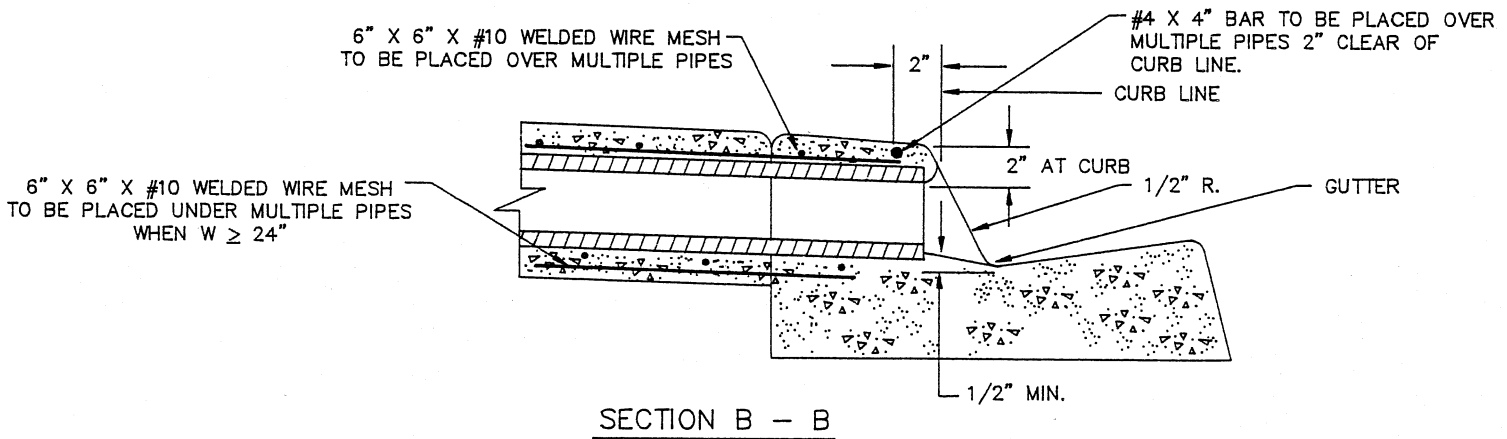
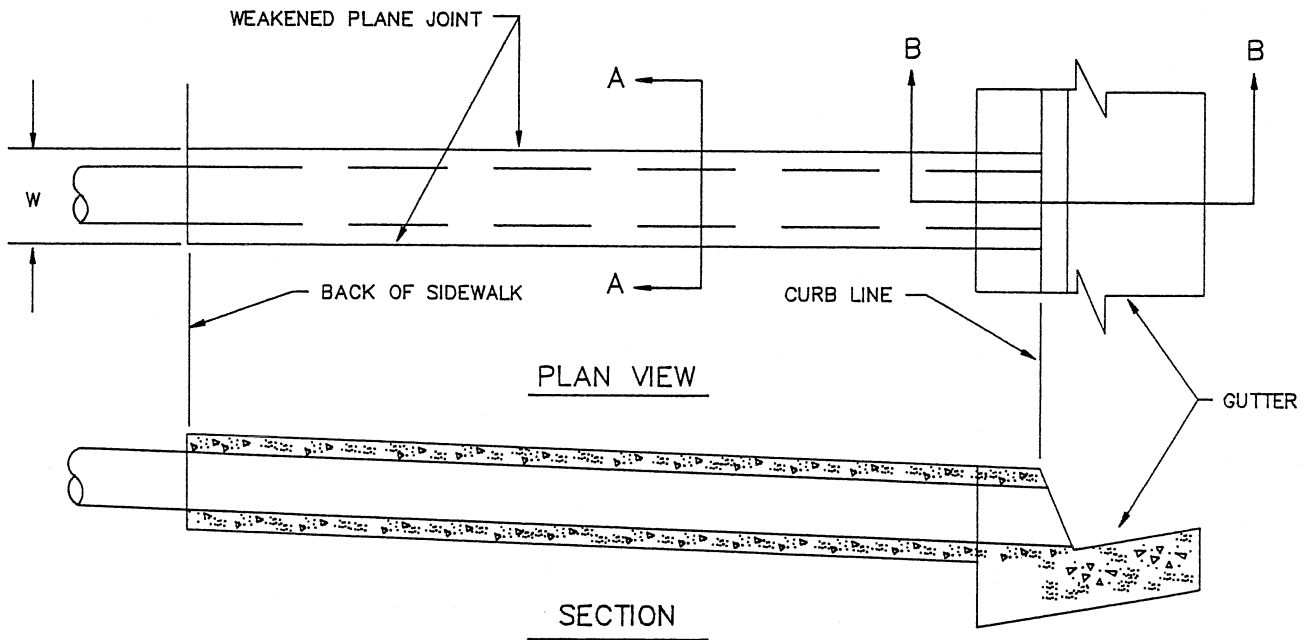

# SIDEWALK UNDERDRAIN PIPE

CITY OF HOLLISTER  
STANDARD PLANS

APPROVED: *Mac [Signature]*

DATE *APRIL 30, 1992*

REVISED

DETAIL *D-13-1* SHEET 1 OF 2

"W" DIMENSION	
NO. OF PIPES	MIN. WIDTH
1	12"
2	18"
3	24"
4	30"

NOTES:

1. PIPE SHALL BE ONE CONTINUOUS LENGTH FROM CURB LINE TO A MINIMUM OF 12" BEYOND BACK OF SIDEWALK.
2. MULTIPLE PIPES TO BE SET A MINIMUM DISTANCE OF 6" APART.
3. CONCRETE SHALL BE 520-C-2500 P.C.C.
4. PIPE SHALL BE 3" CIRCULAR CAST IRON OR RIGID PLASTIC PIPE.
5. WEAKENED PLANE JOINTS SHALL BE 1/8" X 2" WHEN CUT AND 1/8" X 1/2" WHEN FINISHED.
6. ALL CONCRETE SURFACES TO HAVE A LIGHT BROOM FINISH AND TREATED WITH CURING COMPOUND.

WPJ = WEAKENED PLANE JOINTS  
WWM = WELDED WIRE MESH

SIDEWALK UNDERDRAIN PIPE

CITY OF HOLLISTER  
STANDARD PLANS

APPROVED: *[Signature]*

DATE	APRIL 30, 1992
REVISED	
DETAIL	D-13-2 SHEET 2 OF 2

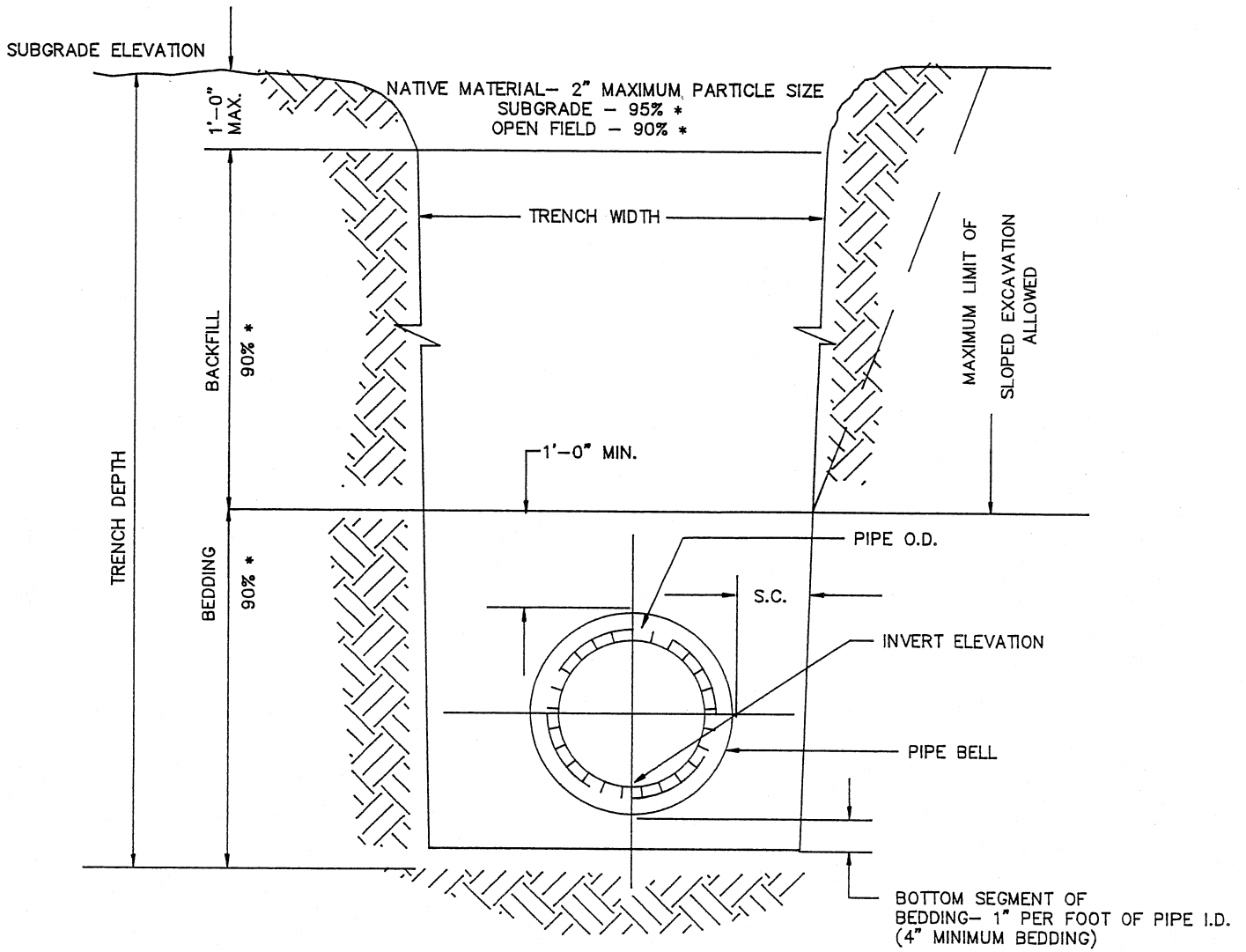

SECTION

NOTES:

1. (\*) INDICATES MINIMUM RELATIVE COMPACTION.
2. SEE DETAIL SHEET E-2 FOR TRENCH RESTORATION ON IMPROVED STREETS.

(SEE BEDDING AND BACKFILL REQUIREMENTS )

S.C. = SIDE CLEARANCE

NORMAL PIPE SIZE	SIDE CLEARANCE
UP TO AND INCLUDING 15"	6" MIN. - 10" MAX.
OVER 15"	8" MIN.

# PIPE BEDDING AND TRENCH BACKFILL

## CITY OF HOLLISTER

### STANDARD PLANS

APPROVED: *[Signature]*

DATE APRIL 30, 1992

REVISED

DETAIL E-1-1 SHEET 1 OF 2

## GENERAL BACKFILL REQUIREMENTS

1. ALL EXISTING, NEW AND FUTURE ROADWAY AREAS WITH TRENCH WIDTH GREATER THAN 2' AND LESS THAN 6'— IMPORTED SANDY MATERIAL WITH S.E. > 30.
2. ALL EXISTING NEW AND FUTURE ROADWAY AREAS WHERE TRENCH WIDTH EXCEEDS 6' AND OPEN FIELDS OUTSIDE PLANNED AND PRESENT RIGHT-OF-WAYS — NATIVE MATERIAL WITH 2" MAXIMUM GRADATION.
3. EXISTING ROADWAYS WITH TRENCH WIDTHS OF 2' OR LESS OR HAVING LESS THAN 25 SQ. FEET OR WHEN DIRECTED IN ANY EXISTING ROADWAY TRENCH — CLASS 100-E-100 P.C.C.

## BEDDING REQUIREMENTS:

### WATER PIPES

- D.I. PIPE — TYPE 1 OR 2
- P.V.C. PIPE — TYPE 1
- POLYETHYLENE TUBING — TYPE 1

### SANITARY SEWER PIPE

- P.V.C. OR A.B.S. COMPOSITE TRUSS PIPE — TYPE 1 OR 3
  - P.V.C. SCH. 40 OR A.B.S. SOLID WALL S.D.R. 23.5 — TYPE 1 OR 3
  - P.V.C. SOLID WALL S.D.R. 35.0 — TYPE 3
  - H.D.P.E. PROFILED WALL PIPE — TYPE 3
- MINIMUM DEPTH OF COVER FROM TOP OF PIPE TO FINISH GRADE FOR ALL SANITARY SEWER INSTALLATIONS SHALL BE 3 FEET, UNLESS PRIOR APPROVAL HAS BEEN OBTAINED FROM THE CITY ENGINEER. FOR COVER LESS THAN 3 FEET, COMPOSITE TRUSS AND SOLID WALL SDR 23.5 PIPE SHALL BE USED. TYPE 3 BEDDING SHALL BE USED ALL CASES WHEN DEPTH TO INVERT IS LESS THAN 3 FEET.

### STORM DRAIN PIPE

- REINFORCED CONCRETE PIPE — TYPES 1, 2, OR 3.
- H.D.P.E. PROFILE PIPE AND P.V.C. SOLID WALL SDR 35.0 PIPE — TYPE 1 OR 3

## BEDDING TYPES

- TYPE 1 — SANDY MATERIAL WITH S.E.> 30. HAND TAMP BOTTOM SEGMENT PRIOR TO PLACING PIPES.
- TYPE 2 — IN FREE DRAINING GRANULAR NATIVE MATERIALS, HAND EXCAVATE AND SHAPE BOTTOM OF TRENCH TO SUPPORT PIPE TO MIN. DEPTH OF O.D./3, REMAINING BEDDING TO BE SANDY MATERIAL WITH S.E.> 30.
- TYPE 3 — CRUSHED AGG. BASE MATERIAL OR CRUSHED MISCELLANEOUS BASE MATERIAL OF FINE GRADATION.

## PIPE BEDDING AND TRENCH BACKFILL — NOTES

CITY OF HOLLISTER

STANDARD PLANS

APPROVED: \_\_\_\_\_

DATE

APRIL 30, 1992

REVISED

DETAIL

F-1-2

SHEET 2 OF 2

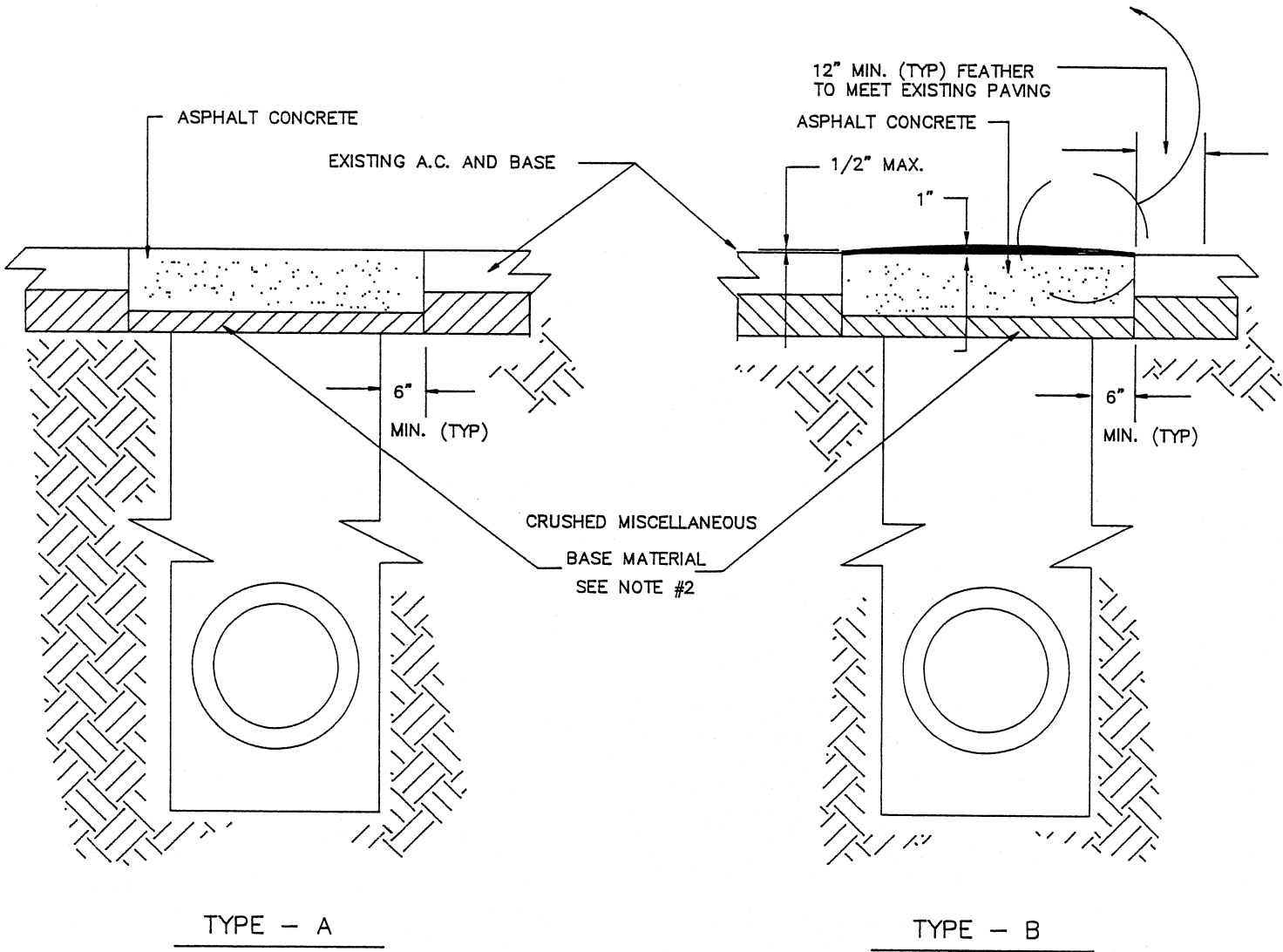
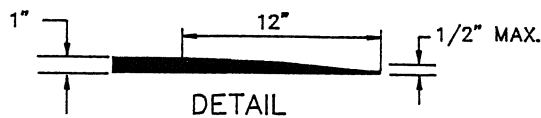

NOTES:

1. EXISTING A.C. SHALL BE CUT AND REMOVED IN SUCH A MANNER SO AS NOT TO TEAR, BULGE OR DISPLACE ADJACENT PAVEMENT. EDGES SHALL BE CLEAN AND VERTICAL. ALL CUTS SHALL BE PARALLEL OR PERPENDICULAR TO STREET CENTERLINE, WHEN PRACTICAL.
2. BASE MATERIAL TO BE REPLACED TO THE DEPTH OF EXISTING BASE AND COMPACTED TO A MIN. 95% RELATIVE COMPACTION. A.C. MAY BE SUBSTITUTED FOR BASE MATERIAL. WHEN USED AS BACKFILL, CLASS 100-E-100 P.C.C. MAY BE SUBSTITUTED FOR BASE MATERIAL.
3. A TACK COAT OF ASPHALTIC EMULSION OR PAVING ASPHALT SHALL BE APPLIED TO EXISTING A.C. AT ALL CONTACT SURFACES, PRIOR TO RESURFACING.
4. ASPHALTIC CONCRETE RESURFACING:
  - A) MINIMUM TOTAL THICKNESS SHALL BE ONE INCH GREATER THAN EXISTING A.C.
  - B) A.C. SHALL HOT PLANT MIX.
  - C) FINISH COURSE FOR TYPE "B" RESURFACING SHALL BE LAID DOWN USING A SPREADER BOX.
5. ALL A.C. RESURFACING SHALL BE SEAL COATED WITH AN EMULSIFIED ASPHALT AND COVERED WITH CLEAN SAND.
6. TYPE B SHALL ONLY BE USED FOR RESTORATION OF LONGITUDINAL TRENCHES WITH WIDTHS EXCEEDING 4 FEET.
7. TYPE A SHALL BE USED FOR LATERAL CROSSINGS.
8. SEE STANDARD PLANS E-1-1 AND E-1-2 FOR PIPE BEDDING AND TRENCH BACKFILL REQUIREMENTS.

TRENCH RESURFACING

CITY OF HOLLISTER  
STANDARD PLANS

APPROVED:

*Max H. Bridges*  
MAX H. BRIDGES, P.C.E. 24157 EXP. 12/31/97

DATE	APRIL 30, 1992
REVISED	
DETAIL	F-2-1

SHEET 1 OF 2

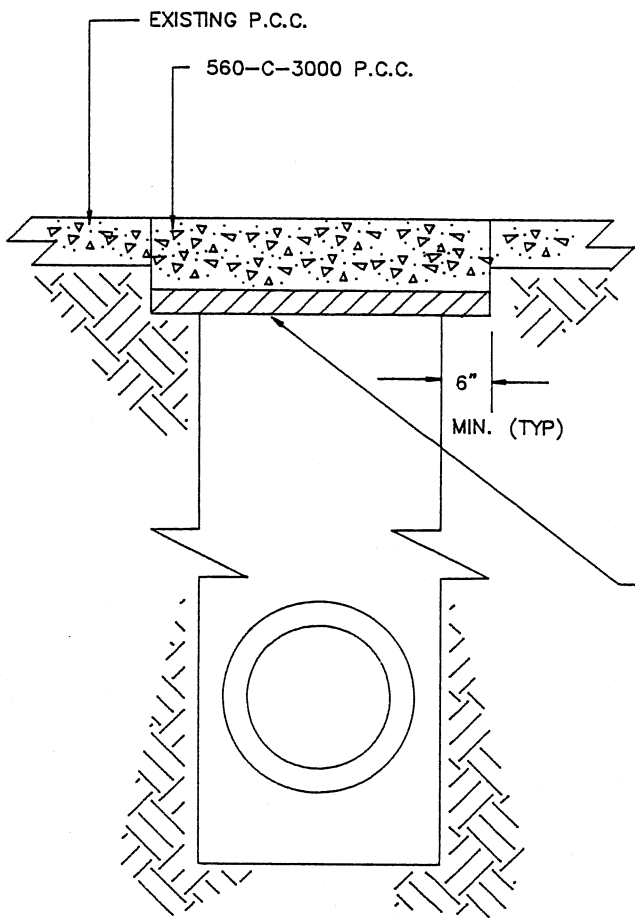

TYPE - C

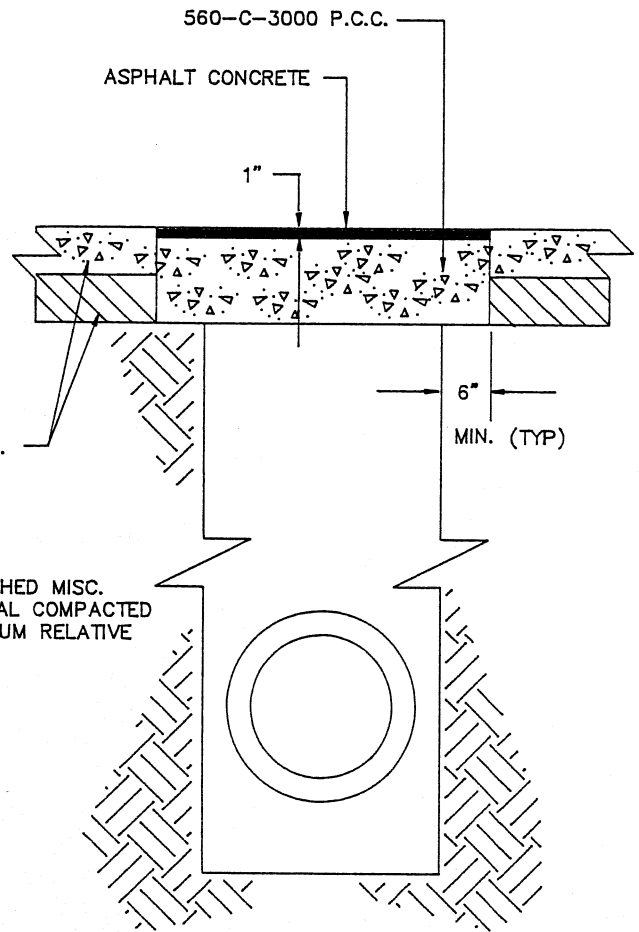

TYPE - D

4" MIN. CRUSHED MISC.  
BASE MATERIAL COMPACTED  
TO 95% MINIMUM RELATIVE  
COMPACTION

GENERAL NOTES:

1. EXISTING A.C. OR P.C.C. SHALL BE CUT AND REMOVED IN SUCH A MANNER SO AS NOT TO TEAR, BULGE, BREAK, OR DISPLACE ADJACENT PAVEMENT. EDGES SHALL BE CLEAN AND VERTICAL. ALL CUTS SHALL BE PARALLEL OR PERPENDICULAR TO STREET CENTERLINE, WHEN PRACTICAL.
2. SEE STANDARD PLANS E-1-1 AND E-1-2 FOR PIPE BEDDING AND TRENCH BACKFILL REQUIREMENTS.

NOTES TYPE - C

1. CONCRETE SHALL BE EQUAL THICKNESS TO EXISTING P.C.C. WITH A MINIMUM OF 7 INCHES.

NOTES TYPE - D

1. A.C. SHALL BE HOT PLANT MIX. A.C. SHALL BE LAID DOWN USING A SPREADER BOX WHEN TRENCH WIDTH EXCEEDS 4 FEET.
2. CONCRETE TO BE PLACED TO DEPTH OF EXISTING BASE WITH A MINIMUM THICKNESS OF 7 INCHES.
3. A TACK COAT OF ASPHALTIC EMULSION OR PAVING ASPHALT SHALL BE APPLIED TO THE A.C. AT ALL CONTACT SURFACES AND TO ALL CONCRETE PRIOR TO PLACING THE NEW A.C.
4. A.C. RESURFACING SHALL BE SEAL COATED WITH AN EMULSIFIED ASPHALT AND COVERED WITH CLEAN SAND.
5. NOT TO BE USED UNLESS SHOWN ON THE PLANS OR APPROVED BY THE PUBLIC WORKS INSPECTOR.

## TRENCH RESURFACING

CITY OF HOLLISTER  
STANDARD PLANS

APPROVED: *[Signature]*

DATE

APRIL 30, 1992

REVISED

DETAIL

E-2-2

SHEET 2 OF 2

# MINIMUM PUBLIC SAFETY REQUIREMENTS FOR UNATTENDED EXCAVATIONS

PRIOR TO THE CONTRACTOR'S DEPARTURE FROM THE SITE OF ANY EXCAVATION, PROVISIONS SHALL BE MADE FOR COMPLIANCE WITH THESE MINIMUM REQUIREMENTS OR EXCAVATIONS SHALL BE BACKFILLED. THE FOLLOWING ARE MINIMUM ACCEPTABLE MEASURES ONLY, AND COMPLIANCE WITH THIS STANDARD DOES NOT RELIEVE THE CONTRACTOR OF HIS OBLIGATION TO PROTECT THE PUBLIC BY ALL NECESSARY MEANS.

FENCES OR COVERS MAY BE OMITTED AT THE OPTION OF THE CONTRACTOR IF THE EXCAVATION IS MORE THAN 6 FEET FROM THE EDGE OF ANY VEHICULAR LANE OR PEDESTRIAN WAY IN ANY OF THE FOLLOWING INSTANCES:

- a. LESS THAN 3 1/2 FEET DEEP WITH SUFFICIENT WARNING DEVICES SUCH AS BARRICADES WITH FLASHERS.
- b. CASE - B, LESS THAN 3 FEET DEEP IN THE VERTICAL PORTION WITH UPPER SIDE SLOPES OF 1:1 OR FLATTER.
- c. IN ANY AREA THAT IS NOT ACCESSIBLE TO THE PUBLIC OR THAT IS MORE THAN 1/2 MILE FROM ANY PLACE OF PUBLIC USE OR HABITATION.

FENCING MAY BE STEEL POST WITH WIRE MESH OR WOODEN RAIL WITH 2" X 4" POSTS. FENCES SHALL BE CONSTRUCTED SUFFICIENTLY TO PRECLUDE A 6 INCH SPHERE. FENCE HEIGHT SHALL BE 6 FEET MINIMUM FOR ANY EXCAVATION EXCEEDING 5 FEET IN DEPTH, WITH 3 1/2 FEET MINIMUM FENCE HIGHT FOR SHALLOWER EXCAVATIONS.

COVERS MAY BE 1/4 INCH STEEL PLATES, 2 INCH PLANKS, OR 3/4 INCH PLYWOOD FOR NON VEHICULAR TRAFFIC. ONLY STEEL PLATES SHALL BE USED FOR VEHICULAR TRAFFIC COVERS. IT IS THE CONTRACTOR'S RESPONSIBILITY TO PROVIDE PROPER TRENCH BRACING AND STEEL PLATES WITH SUFFICIENT STRENGTH TO WITHSTAND TRAFFIC LOADS.

## UNATTENDED EXCAVATION SAFTEY

CITY OF HOLLISTER  
STANDARD PLANS

APPROVED: *W. H. ...*

DATE APRIL 30, 1992

REVISED

DETAIL F-3-1 SHEET 1 OF 2



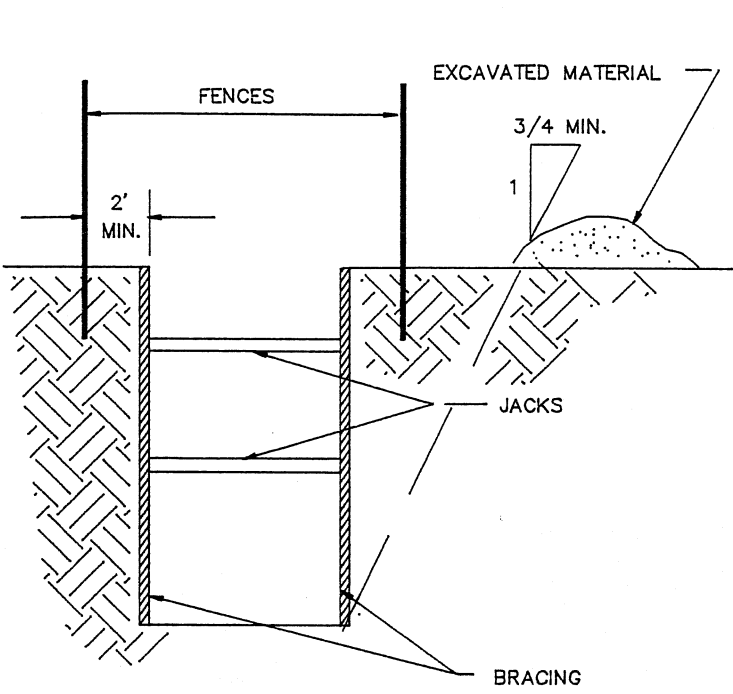

FENCE DETAIL CASE - A

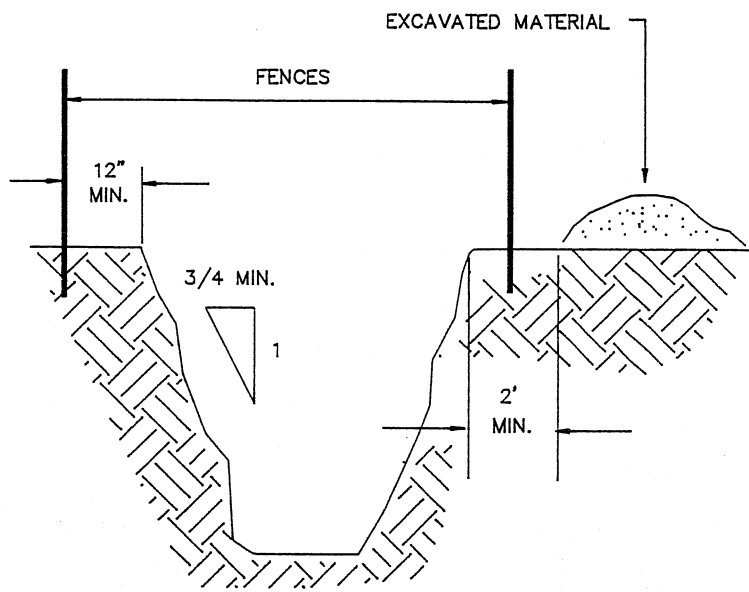

FENCE DETAIL CASE - B

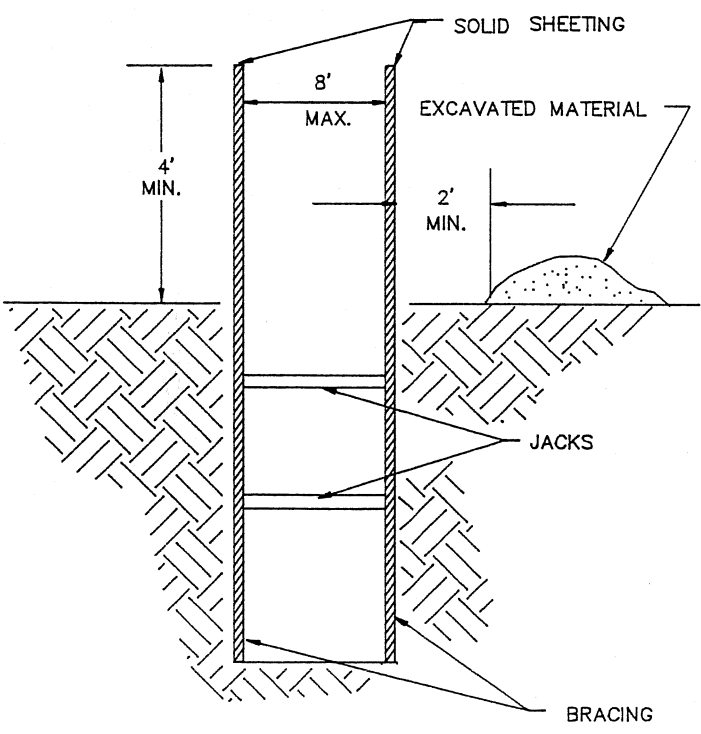

FENCE DETAIL CASE - C

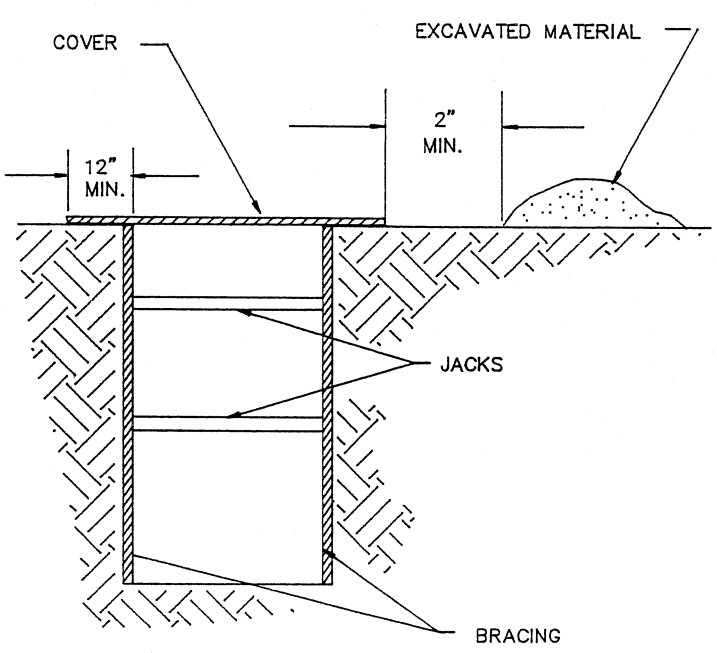

COVER DETAIL

UNATTENDED EXCAVATION SAFETY

CITY OF HOLLISTER  
STANDARD PLANS

APPROVED: *Max H. Bridges*  
MAX H. BRIDGES R.C.E. 24152 - EXP. 12/31/93

DATE	APRIL 30, 1992
REVISED	
DETAIL	E-3-2

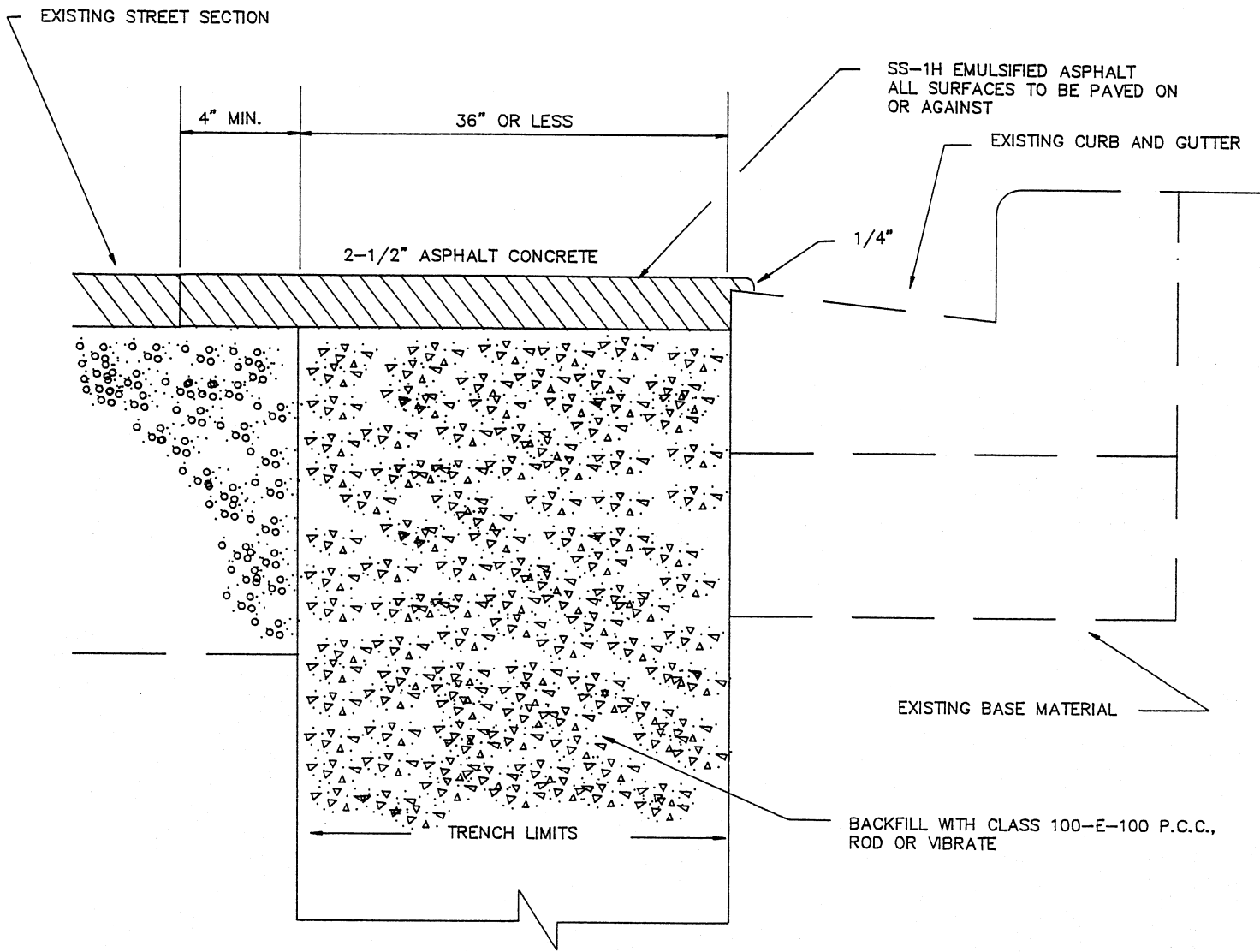

NOTES:

1. USE FOR NARROW TRENCH RESTORATION IN EXISTING ROADWAYS.
2. IF TRENCH IS LOCATED MORE THAN A FOOT OFF OF GUTTERLIP ASPHALT CONCRETE RESTORATION SHALL BE FOR A MINIMUM OF 4" PAST THE TRENCH LIMITS ON EACH SIDE.

## NARROW TRENCH RESTORATION

CITY OF HOLLISTER  
STANDARD PLANS

APPROVED: \_\_\_\_\_

*Max H. Bridges*

MAX H. BRIDGES, P.C.E. 8-1152 EXP. 12/31/97

DATE	APRIL 30, 1992
REVISED	
DETAIL	F-4