

PLAN

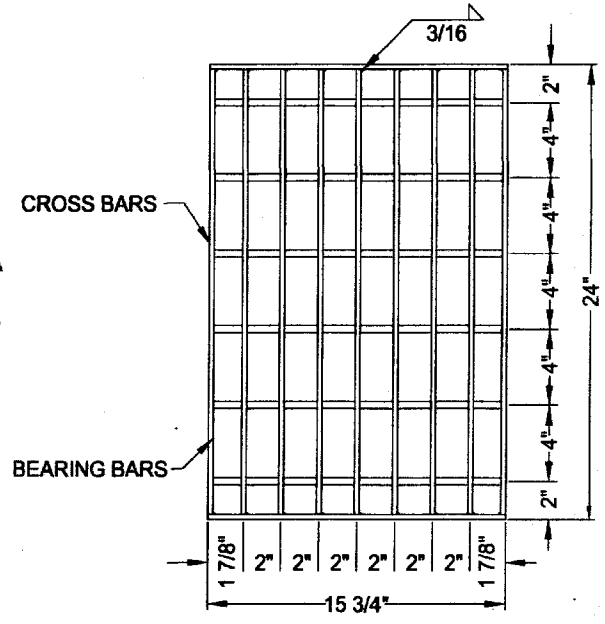

GRATE PLAN

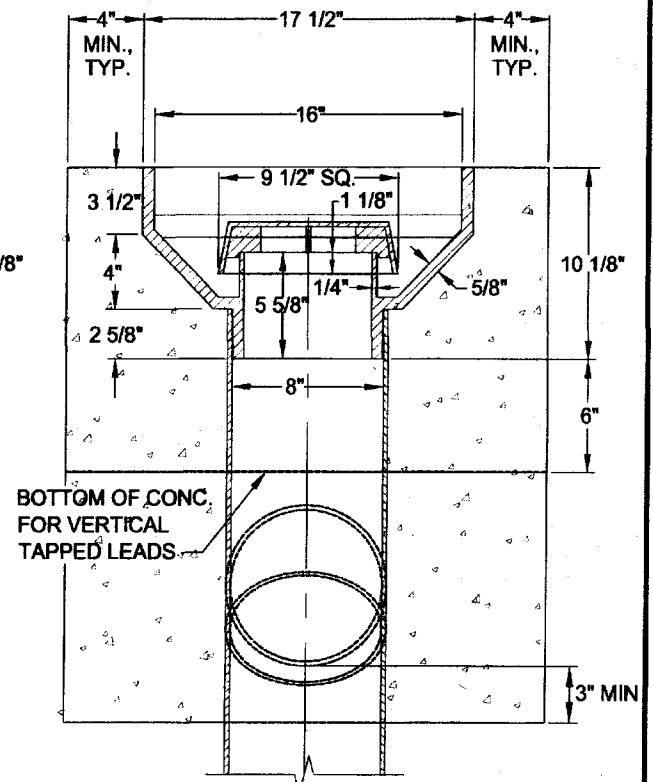
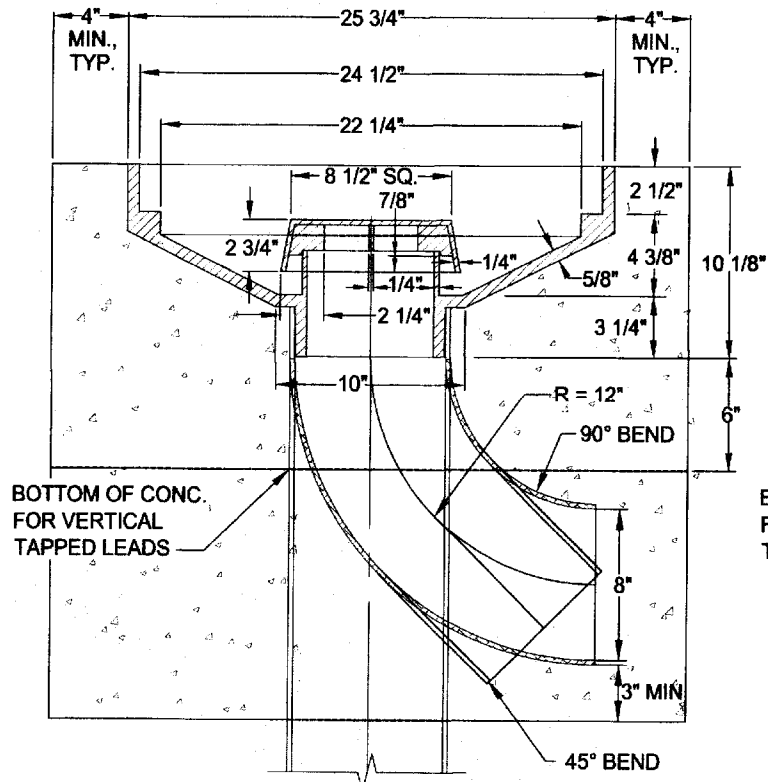

NOTES:

- 1) PIPE & FITTINGS SHALL BE SDR 35 PVC.

REV.	DATE	DESCRIPTION

R:\Utilstois\City\_Sto\_Details\Sewer\_Drainage\S-45